



100%  
Holz aus vorbildlich bewirtschafteten Wäldern  
Drewno z prawidłowo zarządzanych lasów  
Wood from well-managed forests  
FSC® C017604



*Made by*





Sicherheitsbereich  
 Strefa bezpieczeństwa  
 Safety area  
 Zona di sicurezza  
 Área de seguridad  
 Secteur de sécurité  
 Veiligheidsgebied  
 Bezpečnostní oblast  
 Biztonsági terület  
 Зона безопасности  
 Güvenlik alanı  
 نطاق السلامة

Maximale Anzahl der Kinder	67500	-	4
Maksymalna dopuszczalna ilość dzieci	67502	-	1
Maximum number of children	67505	-	3
Quantità massima di bambini	67506	-	3
Nº máximo de niños	67510	-	1
Nombre maximal d'enfants	67511	-	2
Maximaal aantal kinderen	67513	-	1
Maximální počet dětí	67514	-	2
Gyermekek maximális száma	67516	-	1
Максимальное количество детей	67519	-	2
Maksimum çocuk sayısı	67520	-	2
أقصى عدد من الأطفال الجالسين	67521	-	1
	67522	-	2
	67523	-	3
	67524	-	1

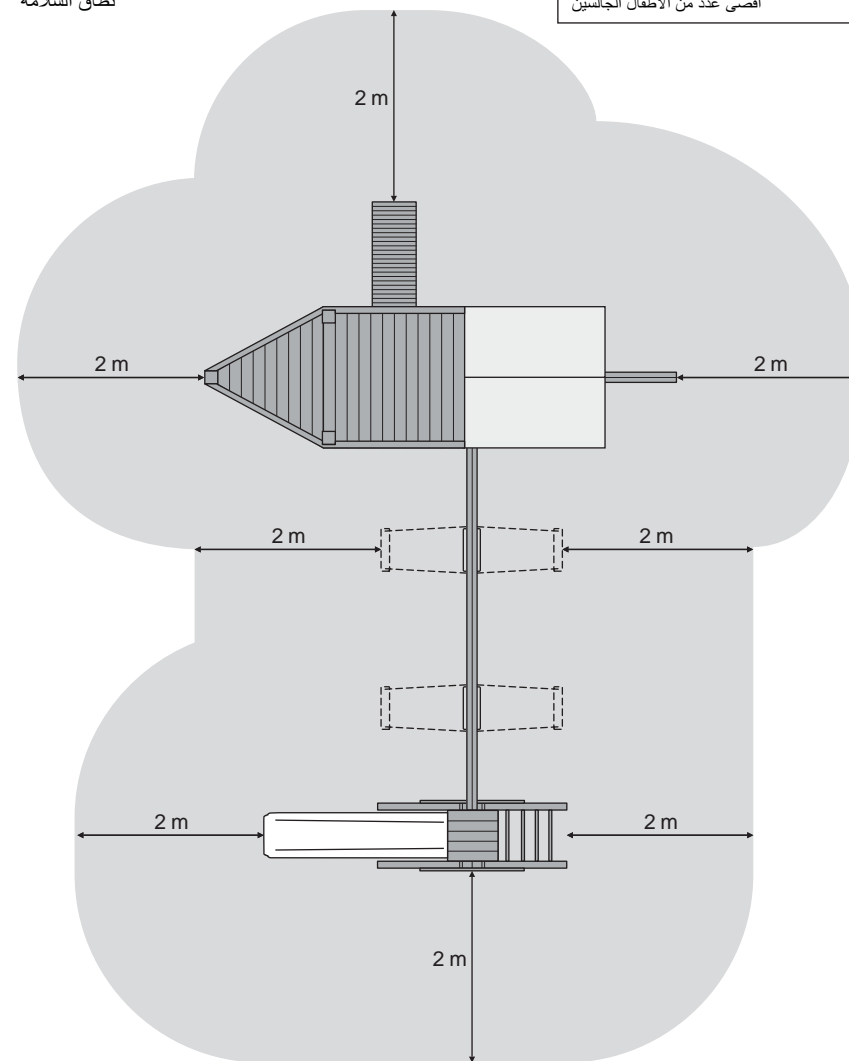
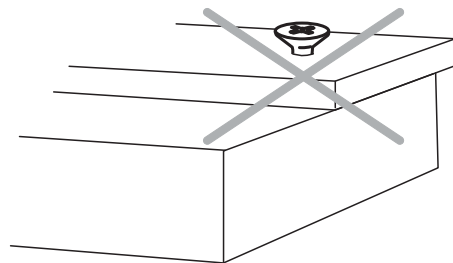
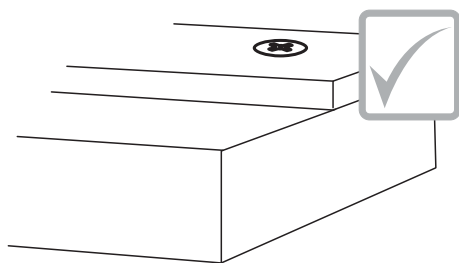
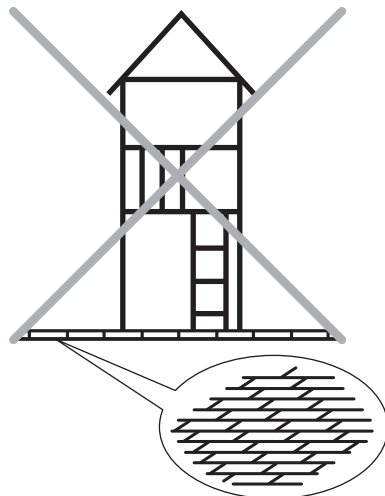
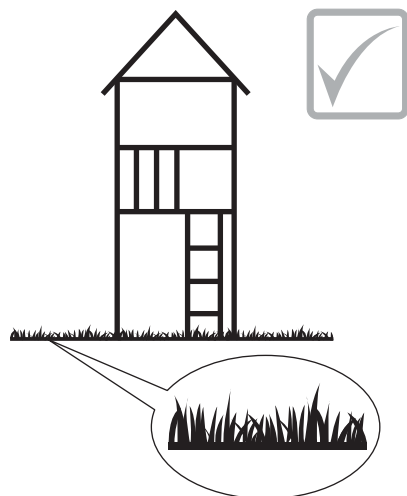
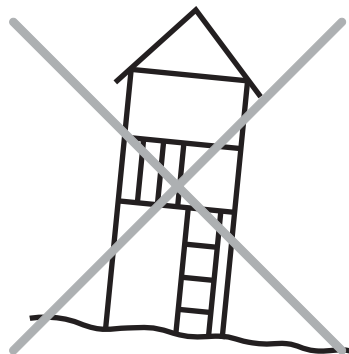
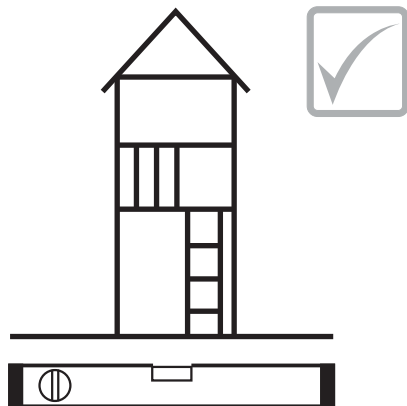

**D** **ACHTUNG!** Nur für den Hausgebrauch!

Ausschließlich für die Verwendung im Freien. Benutzung unter Aufsicht von Erwachsenen.

Maximales Benutzergewicht: 50kg.

Allgemeine Informationen zu Holzmerkmalen finden Sie auf [www.delta-gartenholz.com](http://www.delta-gartenholz.com)

Vor dem Aufbau ist der Bausatz auf Vollständigkeit und Richtigkeit zu kontrollieren. Bei einer Zwischenlagerung vor dem Aufbau darf das Holz nicht luftdicht verpackt oder in einem geschlossenen Raum ohne ausreichende Belüftung gelagert werden, da es durch natürliche Holzfeuchte schnell zu Schimmelbefall oder Stockflecken kommen kann.

Um das Vergrauen und die Rissbildung des Holzes zu minimieren empfehlen wir, das Holz mit einem Schutzanstrich (offenporige Lasur) zu versehen. Alle Maße sind ca.-Maße. Technische Änderungen vorbehalten. Grundsätzlich wird jede akzeptierte Reklamation nur mit der Zusendung von neuen Teilen erledigt und nicht finanziell abgegolten. Fehlerhafte Teile, die bereits verbaut oder gestrichen wurden, sind vom Umtausch ausgeschlossen. Es besteht kein Anspruch auf die Erstattung von weitergehenden Folgekosten wie z.B. Montage- oder Materialkosten (Farben usw.).

Das Spielgerät ist in regelmäßigen Abständen auf etwaige Beschädigung und Fäulnisbefall zu kontrollieren. Die Schraubverbindungen sind in regelmäßigen Abständen auf festen Sitz und Stabilität zu überprüfen. Bei Bedarf sind diese nachzuziehen. Alle beweglichen Teile aus Metall sind zu ölen. Eine fehlende Überprüfung/Wartung kann zur Gefahr werden. Werden bei der obigen Kontrolle nicht reparierbare Fehler oder Beschädigungen festgestellt, sind Sie verpflichtet, das Spielgerät aus dem Verkehr zu ziehen. Bitte bewahren Sie diese Montageanleitung als Beleg auf.

Es dürfen ausschließlich Original-Bodenanker (Art.-Nr. 69245) von Multi-Play verwendet werden. Ansonsten erlischt das TÜV-Zertifikat sowie die Gewährleistung auf das Produkt! Änderungen am Originalspielzeug (z. B. das Hinzufügen eines Anbauteils) müssen nach den Anweisungen des Herstellers ausgeführt werden.

**PL** **UWAGA!** Tylko do domowego własnego użytku!

Wyłącznie do użytku na wolnym powietrzu. Użytkować tylko i wyłącznie pod nadzorem osób dorosłych.

Maksymalna dopuszczalna waga użytkownika: 50kg.

Ogólne informacje na temat typowych cech drewna znajdują Państwo na stronie [www.delta-gartenholz.com](http://www.delta-gartenholz.com)

Przed rozpoczęciem montażu, należy skontrolować zestaw pod kątem kompletności i prawidłowości pojedynczych elementów konstrukcji. Jeśli produkt nie będzie montowany bezpośrednio po kontroli, należy pamiętać, że nie wolno pakować hermetycznie lub składować w zamkniętym pomieszczeniu drewnianych elementów konstrukcji. Bez odpowiedniej cyrkulacji powietrza bardzo szybko może dojść do powstania pleśni lub sinizny.

Aby zminimalizować szarzenie i pęknięcia drewna, zaleca się malowanie elementów ochronną lazurą (lazurowanie z pozostawieniem otwartych porów). Wszystkie wymiary podane są w przybliżeniu. Zmiany techniczne są dopuszczalne. Uznane reklamacje nie będą rozliczane finansowo; przyjętą formą rozliczenia jest wymiana wadliwych elementów. Wadliwe elementy, które zostały już pomalowane i zamontowane nie podlegają wymianie. Nie akceptujemy roszczeń finansowych dotyczących dodatkowych kosztów powstałych w skutek np. montażu, kosztów materiału (farby itd.).

Elementy wyposażenia placu zabaw należy regularnie kontrolować pod kątem uszkodzenia i gnicia. Połączenia śrub należy regularnie kontrolować pod kątem poluzowania i stabilności. Jeżeli zajdzie taka potrzeba, należy je dokręcić. Wszystkie ruchome metalowe części powinny zostać naoliwione. Brak lub niewłaściwa kontrola bądź konserwacja produktu zagraża bezpieczeństwu użytkowników. Jeśli w czasie kontroli zostaną stwierdzone błędy lub uszkodzenia, których nie można naprawić, należy niezwłocznie wycofać produkt z użytku. Prosimy zachować niniejszą instrukcję montażową.

Należy używać tylko i wyłącznie oryginalne kotwy dla zestawu Multi-Play (Nr art. 69245). W innym przypadku system Multi-Play straci certyfikat bezpieczeństwa TÜV oraz prawa z tytułu rękopis! Zmiany w gotowym zestawie (np. domontowanie nowego elementu) muszą być wykonywane zgodnie ze wskazaniami producenta.

**GB** **WARNING!** Only for use in private homes!

For outdoor use only. Use to be supervised by adults.

Maximum user weight: 50kg.

You can find general information on wood features at [www.delta-gartenholz.com](http://www.delta-gartenholz.com)

Check that the construction set is complete and correct before beginning assembly. If stored before assembly, the wood should not be kept in airtight packaging or stored in a sealed room without sufficient ventilation, since the natural moisture in the wood can lead to mould or staining.

To minimise greying or cracking in the wood, we recommend using a protective varnish (open-pore glaze). All measurements given are approximate. In general, complaints are rectified by the provision of new parts, rather than financial remuneration. Faulty parts which have already been assembled or varnished cannot be exchanged. There is no claim to remuneration for any further follow-up costs, such as assembly or material costs (paints etc.).

The play equipment must be checked regularly for any damage or rot. The screw connections should be checked regularly to ensure that they are still sitting properly and are stable. Tighten if necessary. All metal moving parts must be oiled. A lack of inspection/maintenance can be dangerous. If faults or damage which cannot be repaired is discovered during the inspection described above, you must take the play equipment out of use. Please keep these assembly instructions for your records.

Only original ground anchors (Item no. 69245) from Multi-Play can be used. If others are used, the TÜV certificate and the product guarantee no longer apply. Any modifications to the original toy (e.g. adding an extension part) must be made in accordance with the manufacturer's instructions.

**I** **ATTENZIONE!** Solo per il settore privato, domestico!

Esclusivamente per un utilizzo all'aperto. Da utilizzare sotto la sorveglianza di adulti.

Peso massimo dell'utente: 50kg.

Informazioni generali sulle caratteristiche del legno sono disponibili su [www.delta-gartenholz.com](http://www.delta-gartenholz.com)

Prima del montaggio bisogna verificare la completezza e la conformità della scatola di montaggio. In caso di stoccaggio temporaneo prima del montaggio, il legno non deve essere confezionato ermeticamente né conservato in una stanza chiusa e senza sufficiente aerazione in quanto, a causa dell'umidità naturale del legno, si possono verificare rapidamente infestazioni di muffa o macchie dovute allo stoccaggio.

Per ridurre la possibilità di crepe o di ingrigimento del legno, consigliamo di provvedere con una vernice protettiva (verniciatura velata a poro aperto). Tutte le dimensioni sono approssimative. Ci riserviamo eventuali modifiche tecniche. Sostanzialmente ogni reclamo accolto viene risolto con la spedizione di pezzi nuovi, senza compensi finanziari. È escluso il cambio di pezzi difettosi già rovinati o verniciati. Non si ha alcun diritto al rimborso di spese successive, ad es. per il montaggio o per il materiale (colori, ecc.).

Sono da controllare periodicamente eventuali danneggiamenti e deterioramenti del gioco. Vanno periodicamente controllati il corretto serraggio e la stabilità delle viti di connessione. Se necessario, vanno strette ulteriormente. Tutte le parti metalliche mobili vanno oleate. Una mancata verifica/manutenzione può causare pericoli. Qualora nei suddetti controlli vengano rilevati difetti o danni non riparabili, il gioco dovrà essere obbligatoriamente ritirato dalla circolazione. Si prega di conservare queste istruzioni per il montaggio come ricevuta.

Devono essere utilizzati esclusivamente tiranti d'ancoraggio originali (Art. n. 69245) Multi-Play. In caso contrario si estingue la certificazione TÜV e la garanzia sul prodotto! Eventuali modifiche al gioco (ad es. l'inserimento di un pezzo di ampliamento) devono essere effettuate in base alle indicazioni del produttore.

**E ¡ATENCIÓN!** ¡Únicamente pensado para su uso en el ámbito doméstico!

Únicamente pensado para su uso en exteriores. Utilizar bajo la atenta mirada de un adulto.

Peso máximo soportable: 50kg.

Encontrará información general sobre las características de la madera en [www.delta-gartenholz.com](http://www.delta-gartenholz.com)

Antes de proceder a su montaje, asegúrese de que el juego se encuentre en perfecto estado y no tenga piezas defectuosas. Si va a almacenar temporalmente la madera antes de su montaje, evite envolverla herméticamente o depositarla en un espacio cerrado sin suficiente ventilación, pues la humedad de la madera natural puede transformarse rápidamente en una plaga de hongos o manchas de moho.

A fin de minimizar el envejecimiento y la formación de grietas en la madera recomendamos revestirla con una capa de pintura protectora (barniz poroso). Todas las medidas son referencias aproximadas. Sujeto a posibles modificaciones técnicas. En principio, las reclamaciones aceptadas únicamente serán compensadas mediante el envío de piezas nuevas, no habrá compensación económica. Las piezas defectuosas que ya hayan sido montadas o pintadas quedan excluidas de cualquier cambio. Queda excluido el derecho al reembolso de los costes adicionales originados posteriormente, como por ejemplo los costes de montaje o de material (pinturas, etc.).

El juguete ha de ser revisado regularmente ante la aparición de posibles desperfectos y plagas de moho. Las juntas de los tornillos han de comprobarse regularmente para garantizar su correcta fijación y estabilidad. Si fuera necesario, deberá apretarlos. Todas las piezas móviles de metal han de engrasarse. Una revisión/mantenimiento defectuoso puede resultar peligroso. Si durante los controles arriba indicados se detectaran fallos o defectos irreparables, está obligado a retirar el juguete. Por favor, conserve estas instrucciones de montaje como comprobante.

Solamente pueden utilizarse anclajes para el suelo (nº art. 69245) originales de Multi-Play. ¡De lo contrario, tanto el certificado TÜV como la garantía del producto quedarán excluidos! Los cambios en el juguete original (p. ej. la adición de piezas) deben realizarse conforme a las indicaciones del fabricante.

**F ATTENTION !** Réservée à une zone privée, domestique !

Uniquement pour une utilisation en plein air. À utiliser sous la surveillance d'un adulte.

Poids maximal de l'utilisateur : 50 kg.

Retrouvez les informations générales relatives aux caractéristiques du bois sur [www.delta-gartenholz.com](http://www.delta-gartenholz.com)

Vérifiez avant le montage que le kit est complet et conforme. En cas de stockage provisoire avant le montage, le bois ne doit pas être emballé sous vide ou stocké dans une pièce fermée, sans une aération suffisante, car cela peut rapidement faire apparaître de nombreuses tâches de moisissure en raison de l'humidité naturelle du bois.

Afin d'éviter que le bois ne grise et ne se fissure, nous recommandons de le recouvrir d'un enduit de protection (lasure poreuse). Toutes les mesures sont approximatives. Sous réserve de modifications techniques. En principe, chaque réclamation acceptée n'est réglée qu'avec l'envoi de nouvelles pièces et n'est pas indemnisée financièrement. Des éléments défectueux qui ont déjà été montés ou peints ne peuvent pas être échangés. Il n'existe aucun droit au remboursement des frais ultérieurs supplémentaires tels que les frais de montage ou de matériaux (peinture, etc.).

Le jouet doit faire l'objet de contrôles réguliers afin de déceler des éventuels dommages et l'apparition de moisissure. Les boulons doivent être régulièrement contrôlés pour assurer la stabilité et une bonne fixation des sièges. En cas de besoin, ils doivent être resserrés. Tous les éléments mobiles en métal doivent être huilés. Un mauvais contrôle/entretien peut devenir un danger. Si, lors des contrôles précédemment cités, des défauts ou des dommages non réparables sont détectés, vous êtes tenus de ne plus utiliser le jouet. Veuillez conserver cette notice de montage comme preuve.

Seul le tirant d'ancrage d'origine (nº art. 69245) de Multi-Play peut être utilisé. Dans le cas contraire, le certificat TÜV ainsi que la garantie du produit prennent fin. Des modifications apportées au jouet d'origine (par ex. l'ajout d'un élément) doivent être effectuées après instructions du fabricant.

**NL OPGELET!** Uitsluitend voor het privé-, huishoudelijk gebruik!

Uitsluitend voor gebruik in de buitenlucht. Gebruik onder het toezicht van volwassenen.

Maximaal gewicht gebruiker: 50kg.

Algemene informatie over houtkenmerken vindt u op [www.delta-gartenholz.com](http://www.delta-gartenholz.com)

Vóór de opbouw dient gecontroleerd te worden of de bouwset compleet en juist is. Bij een tussenopslag vóór de opbouw mag het hout niet luchtdicht verpakt of in een gesloten ruimte zonder voldoende ventilatie opgeslagen worden, aangezien er door natuurlijke houtvochtigheid snel schimmelaantasting of vochtvlekken kunnen ontstaan.

Om het vergrauwen en de scheurvorming van het hout tot een minimum te beperken, raden wij aan het hout te voorzien van een beschermlaag (beitsing met open poriën). Alle maten zijn worden bij benadering gegeven. Technische wijzigingen voorbehouden. In principe wordt iedere geaccepteerde claim alleen afgehandeld met de toezending van nieuwe onderdelen en niet financieel vereffend. Defecte onderdelen, die reeds gemonteerd of geveerd zijn, zijn uitgesloten van de omwisseling. Er kan geen aanspraak worden gemaakt op de vergoeding van verdergaande vervolgcosten zoals bv. montage- of materiaalkosten (verven enz.).

Het speeltoestel dient met regelmatige tussenpozen op eventuele beschadiging en verrotting gecontroleerd te worden. De schroefverbindingen moeten met regelmatige tussenpozen op goed vastzitten en stabiliteit gecontroleerd worden. Indien nodig moeten deze verder aangedraaid worden. Alle bewegende metalen onderdelen moeten geolied worden. Het niet uitvoeren van controle/onderhoud kan gevaar opleveren. Als er bij bovenstaande controle niet-repareerbare fouten of beschadigingen vastgesteld worden, bent u verplicht om het speeltoestel uit de circulatie te nemen. Bewaar deze montagehandleiding als bewijsstuk.

Er mogen uitsluitend originele bodemankers (art.nr. 69245) van Multi-Play gebruikt worden. Anders vervallen het TÜV-certificaat en de garantie op het product! Wijzigingen aan het originele speelgoed (bv. het toevoegen van een aanbouwdeel) moeten volgens de aanwijzingen van de fabrikant uitgevoerd worden.

**CZ UPOZORNĚNÍ!** Pouze pro soukromé, domácí použití!

Pouze pro venkovní používání. Používání pouze pod dohledem dospělých.

Maximální hmotnost uživatele: 50 kg.

Všeobecné informace ke vlastnostem dřeva najdete na [www.delta-gartenholz.com](http://www.delta-gartenholz.com)

Před montáží zkontrolujte kompletnost a správnost sady dílů. Při skladování před montáží dřeva nesmí být vzduchotěsně zabaleno nebo skladováno v uzavřených prostorách bez dostatečného větrání, protože v důsledku přirozené vlhkosti dřeva může rychle dojít k napadení plísní nebo tvorbě skvrn po plísní.

Pro minimalizaci šednutí dřeva a vzniku prasklin doporučujeme dřevo opatřit ochranným nátěrem (prodyšnou lazuroou). Všechny rozměry jsou přibližné. Právo technických změn je vyhrazeno. V zásadě bude každá akceptovaná reklama vyřízena zasláním nových dílů a nebude poskytnuta finanční náhrada. Výměna vadných dílů, které již byly smontovány nebo natřeny, je vyloučena. Nevzniká žádný nárok na náhradu souvisejících nákladů, jako například nákladů na montáž nebo materiálu (barva apod.).

Houpačku v pravidelných intervalech kontrolujte na případná poškození a napadení plísní. V pravidelných intervalech kontrolujte pevné dotažení a stabilitu šroubových spojů. V případě potřeby je utáhněte. Všechny pohyblivé kovové části naolejujte. Chybějící kontrola / údržba může být nebezpečná. Pokud při výše uvedené kontrole zjistíte neopravitelné závady nebo poškození, jste povinni houpačku vyřadit z používání. Tento návod k montáži prosím uchovejte jako doklad.

Používejte výhradně originální podlahové kotvy (objednací číslo 69245) k Multi-Play. V opačném případě zaniká platnost certifikátu TÜV a záruka na výrobek! Změny originální hračky (např. doplnění dodatečného dílu) musí být provedeny podle pokynů výrobce.

## **H** FIGYELEM! Felhasználás csak magán, ill. otthoni területen!

Kizárólag a szabadban való felhasználásra. Használat felnőtt felügyelete mellett.

Maximális terhelési súly: 50kg.

Általános információkat az egyes fa típusokhoz a [www.delta-gartenholz.de](http://www.delta-gartenholz.de) oldalon talál.

A felépítés előtt ellenőrizze, hogy a felszerelés teljes- és megfelelő-e. A felszerelés köztes tárolása esetén, ügyeljen arra, hogy a fa ne légmentesen legyen becsomagolva, vagy olyan zárt helyen tárolva, ahol a levegőzés nincs megfelelően biztosítva, mivel a természetes fanedvesség miatt a felszínen penész, a fa mintázatán folt képződhet.

A fa megszürkülése és a repedésképződés megátolása érdekében ajánljuk, hogy kenjen fel védőfestékréteget (nyitott porúsú felületlazúr) a fapelületre. Minden méret körülbélüli méret. Technikai változásokat fenntartunk. Minden elfogadott reklamáció alapvetően egy új alkatrész megküldésével intéződik, nem pedig pénzvisszafizetéssel. Azok a hibás alkatrészek, amelyek már beépítésre kerültek, vagy le lettek festve, nem cserélhetőek vissza. Az egyéb költségek mint pl. szerelési vagy anyagköltségek (festék stb.) visszatérítésére nincs mód.

A játékoszéköt rendszeresen ellenőrizze, hogy nincs-e rajta sérülés vagy korhadásra utaló nyom. A csavarok illeszkedését rendszeres időközönként ellenőrizni kell, hogy elég stabilak- és szorosak-e. Ha szükséges, húzzon rajtuk. Minden elmozdítható fém alkatrészt olajozni kell. A hiányzó karbantartás/ellenőrzés veszélyt okozhat. Amennyiben a fentiek szerinti ellenőrzés során kijavíthatatlan hibát vagy rongálódást észlel, köteles kivonni az eszközt a forgalomból. Kérjük őrizze meg ezt a szerelési útmutatót.

Kizárólag eredeti Multi-Play talajhorgonnyal (Cikkszám: 69245) használható. Különben megszűnik a TÜV -bizonyítvány, valamint a termékre való garancia! Az eredeti terméken való változtatásokat (pl. új alkatrész hozzáadása) a gyártó utasításai szerint kell végrehajtani.

## **RUS** ВНИМАНИЕ! Только для частной, придомовой территории!

Исключительно для применения на улице. Использование под присмотром взрослых.

Максимальный вес ребенка: 50 кг.

Общую информацию о свойствах древесины можно найти на сайте [www.delta-gartenholz.com](http://www.delta-gartenholz.com)

Перед монтажом набор следует проверить на комплектность и правильность. При промежуточном хранении перед монтажом не разрешается герметично упаковывать деревянные компоненты или хранить их в закрытом помещении с плохой вентиляцией, поскольку естественная влажность древесины может быстро привести к образованию плесени или пятен от сырости.

Для минимизации серой окраски или растрескивания древесины мы рекомендуем обработать ее защитным составом (глазурью с открытыми порами). Все размеры являются приблизительными. Мы оставляем за собой право на технические изменения. В общем и целом любая принятая рекламация влечет за собой отправку новых деталей, а не возмещение денежных средств. Неисправные детали, уже установленные или окрашенные, замене не подлежат. Не принимаются требования о возмещении дополнительных расходов, например, расходов на монтаж или материалы (краска и т. д.).

Регулярно контролировать игровое оборудование на возможные повреждения и случаи гниения. Болтовые соединения следует регулярно проверять на прочную посадку и устойчивость. При необходимости их необходимо подтягивать. Все подвижные детали из металла подлежат смазке. Невыполнение проверки/техобслуживания может привести к опасности. Если в ходе упомянутого выше контроля обнаруживаются дефекты или повреждения, вы обязаны прекратить использование игрового оборудования. Просьба сохранить данное руководство по монтажу в качестве доказательства.

Разрешается использовать только оригинальные наполные анкеры (арт. № 69245) Multi-Play. В противном случае сертификат TÜV и гарантия на данное изделие теряют свою силу! Модификации оригинальной игрушки (например, добавление навесной детали) должны выполняться в соответствии с инструкциями производителя.

## **TR** DİKKAT! Sadece şahsi ikamet alanında kullanılmak içindir!

Sadece kapalı olmayan alanlarda kullanılacaktır. Kullanım yetişkinlerin gözetimi altında yapılacaktır.

Maksimum kullanıcı ağırlığı: 50kg.

Ağaçların özellikleri hakkındaki genel enformasyonları [www.delta-gartenholz.com](http://www.delta-gartenholz.com) sayfasında bulabilirsiniz.

Kurulumdan önce kurulum takımının tam ve doğru olduğu kontrol edilmelidir. Kurulumdan önce bir ara depolama durumunda ağacın hava almayacak şekilde ambalajlanmış olması veya yeteri kadar havalandırılmayan kapalı bir odada depolanması yasaktır, çünkü ağacın tabii nemliliğinden dolayı çabuk bir şekilde nebat küflenmesi veya beneklenmeler meydana gelebilir.

Ağacın bozlaşmasının ve yarık meydana gelmesinin minimum yüzeye düşürülmesi için ağacı bir koruma cilası (açık gözenekli cilalanmasını tavsiye ediyoruz. Verilmiş olan bütün ölçüler yaklaşık ölçülerdir. Teknik değişiklik hakkı saklı tutulmaktadır. Genel olarak kabul edilen bütün reklamsasyonlar yeni bir parça ile değiştirilmektedir ve karşılığında bir ücret talep edilmemektedir. Kurulmuş veya cilalanmış olan hatalı parçaların değiştirilmesi mümkün değildir. Montaj- veya materyal (boya v. b.) giderleri gibi müteakip masrafların geriye ödenmesini talep etme hakkı bulunmamaktadır.

Bu oyun cihazında düzenli aralıklara hasar durumu ve çürüme durumları kontrol edilmelidir. Cıvata bağlantıları düzenli aralıklarla sağlam olarak oturdukları ve dayanıklılıkları kontrol edilmelidir. İhtiyaç durumunda tekrar sıkılmalıdır. Metalden imal edilmiş olan bütün hareketli parçalar yağlanmalıdır. Yerine getirilmemiş olan bir kontrol/bakım tehlike meydana getirebilir. Yukarıda izah edilmiş olan kontroller esnasında tamir edilmesi mümkün olmayan hatalar veya hasarlar tespit edildiğinde bu oyun cihazını devre dışı bırakmak mecburiyetindediniz. Lütfen bu montaj kılavuzunu belge olarak saklayın.

Orijinal zemin kilidi olarak (Art.-No. 69245) sadece Multi-Play kullanılacaktır. Aksi takdirde TÜV-Sertifikası geçerli değildir ve ürün için garanti hakkı da ortadan kalmaktadır! Orijinal oyun cihazında yapılacak olan değişiklikler (örneğin bir kurulum paçasının ilave edilmesi) imalatçının talimatları doğrultusunda yapılmak zorundadır.

## **AR**

**تحذیر!** صالح فقط للاستخدام في المناطق الخاصة والمنزلية!

يقتصر الاستخدام على الأماكن المفتوحة، ويستخدم تحت إشراف الكبار.

أقصى وزن يمكن تحميله: 50 كجم.

يمكنك العثور على معلومات عامة عن خصائص الخشب على الموقع [www.delta-gartenholz.com](http://www.delta-gartenholz.com)

قبل التركيب يجب التأكد من صحة واكتمال مجموعة التركيب، وفي حالة التخزين المؤقت قبل التركيب يحظر تغليف الخشب وعزله تماما عن الهواء، ويحظر تخزينه في غرفة مغلقة بدون تهوية كافية، حيث أنه قد يحدث تبرع أو تظهر بقع من الرطوبة بشكل سريع نظراً لرطوبة الخشب الطبيعية.

لتحجيم تحول لون الخشب إلى الرمادي وتكون الشقوق به، نوصي بدهن الخشب بدهان واق (طلاء ذي فتحات مسامية)، جميع المقاسات تعتبر مقاسات تقريبية. ينبغي عدم تغيير التعديلات التقنية. في الأساس تتم معالجة الشكاوى المقبولة بإرسال قطع جديدة فقط، وليس بتعويض مالي، أما الأجزاء المعيبة التي تم دهنها أو تركيبها فلا تدخل ضمن الاستبدال، ولا نقبل بأي مطالب باسترجاع التكاليف التابعة اللاحقة مثل تكاليف التركيب وثمان المواد (الألوان وغير ذلك).

ينبغي فحص اللعبة على فترات منتظمة للتأكد من خلوها من أي أضرار محتملة أو بقع تعفن، فغياب الفحص/الصيانة يمكن أن يؤدي إلى حدوث خطر، و ينبغي فحص وصلات المسامير اللولبية على فترات منتظمة للتأكد من ثباتها وتركيبها بإحكام، و ينبغي عند الحاجة إحكام ربطها، كما ينبغي تزييت الأجزاء المعدنية المتحركة، فإذا تم اكتشاف أخطاء أو أضرار لا يمكن إصلاحها عند الفحص المذكور سابقاً، يتعين عليك منع استخدام اللعبة. يرجى الاحتفاظ بدليل التركيب هذا للرجوع إليه.

ينبغي الاقتصاد على استخدام قطع التثبيت الأرضية الأصلية التابعة لنظام Multi-Play (رقم القطعة: 69245)، وإلا تلغى شهادة رابطة الفحص التقني TÜV وكذلك يُلغى ضمان المنتج! يجب إجراء التعديلات على اللعبة الأصلية (كإضافة قطعة جديدة) وفقاً لإرشادات المنتج.



5900236675001

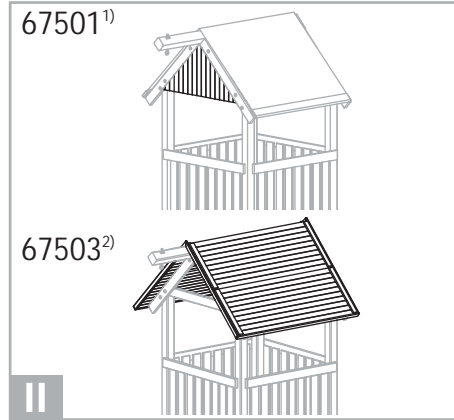

5900236675018<sup>1)</sup>  
5900236675025<sup>2)</sup>

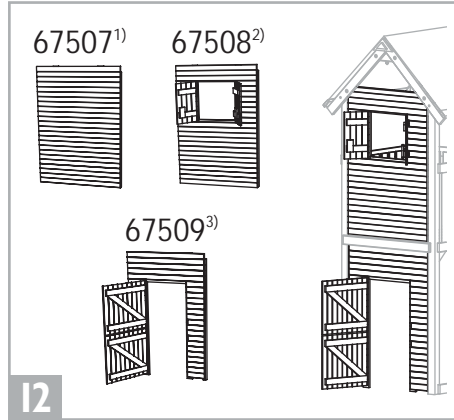

5900236675070<sup>1)</sup> 5900236675087<sup>2)</sup>  
5900236675094<sup>3)</sup>



5900236675117

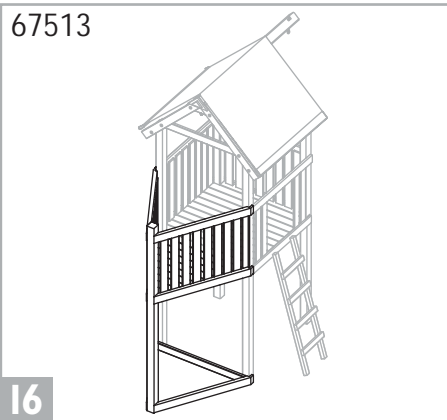

5900236675131



5900236675148<sup>1)</sup>  
5900236675155<sup>2)</sup>



5900236675162<sup>1)</sup>  
5900236675179<sup>2)</sup>



5900236675056



5900236675063  
5900236675124

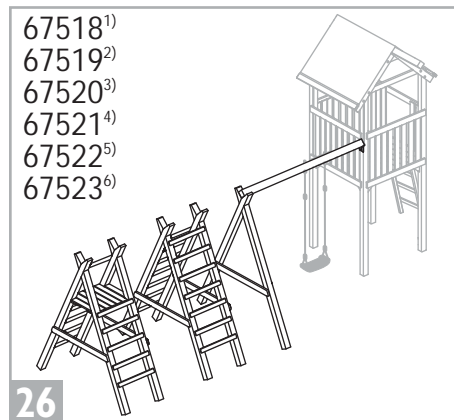

5900236675186<sup>1)</sup> 5900236675209<sup>3)</sup> 5900236675223<sup>5)</sup>  
5900236675193<sup>2)</sup> 5900236675216<sup>4)</sup> 5900236675230<sup>6)</sup>



5900236675100<sup>1)</sup>  
5900236675247<sup>2)</sup>

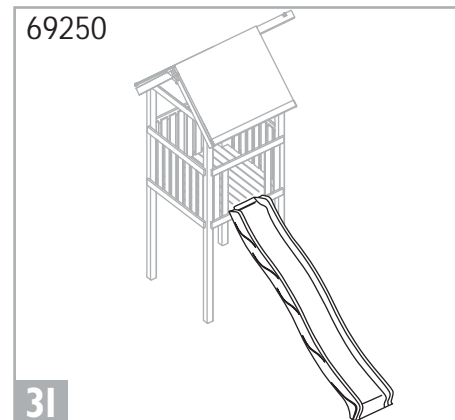

5900236692503

67500

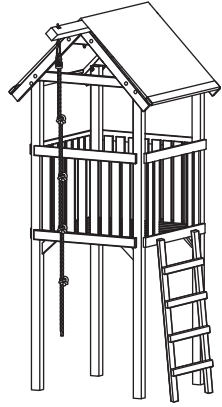

5900236675001

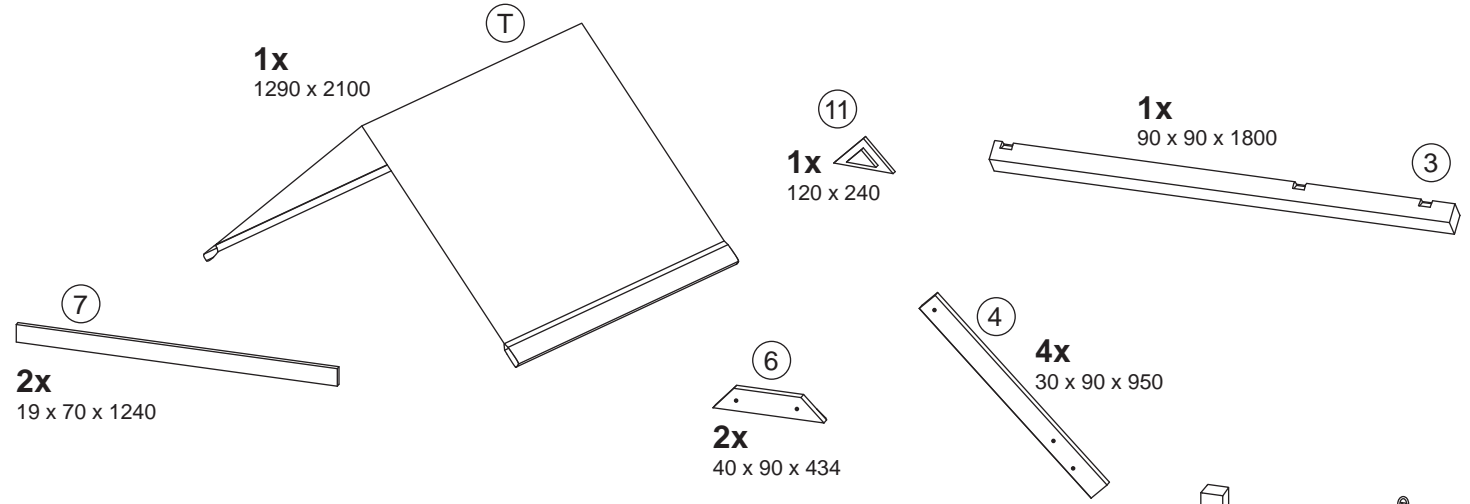

- 64x (A) - 5 x 70
- 122x (B) - 3,5 x 35
- 8x (C) - 5 x 120
- 20x (D) - 4 x 60



- 2x (E) - 4 x 50

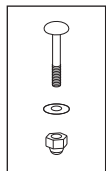
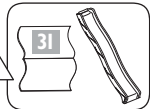

- 2x (G) - M10 x 210
- 4x (H) - M8 x 130
- 4x (I) - M8 x 80
- 4x (J) - M8 x 70

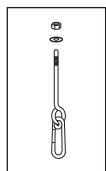

- 1x (U) - M12 x 140

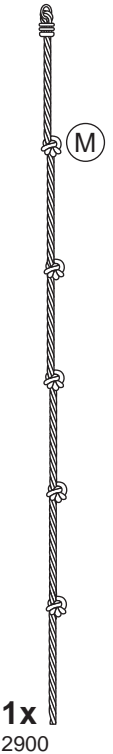
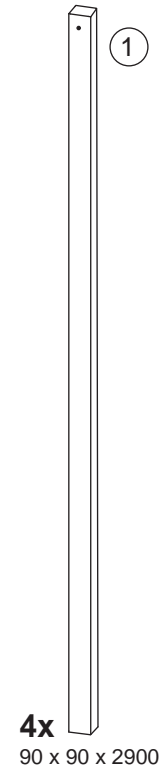
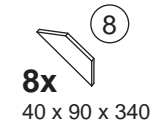
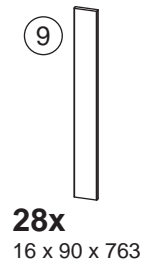
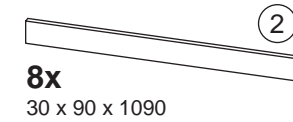
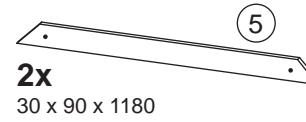
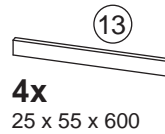
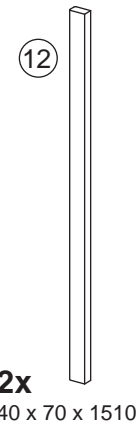
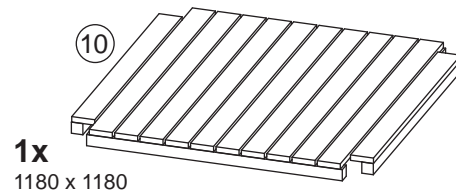

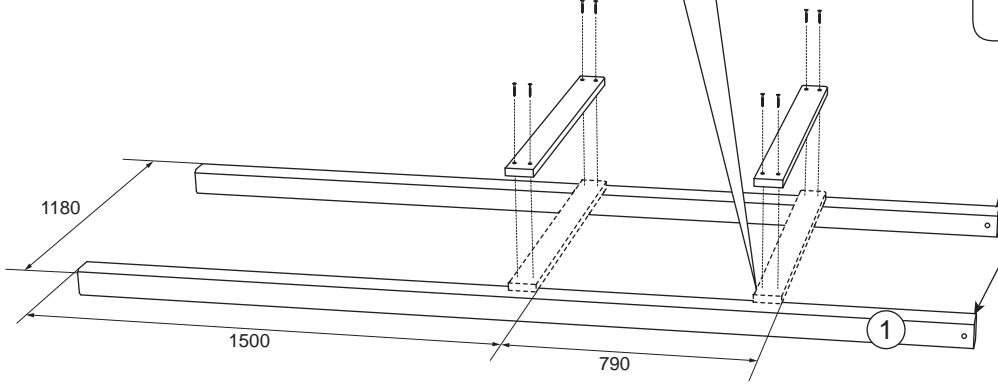
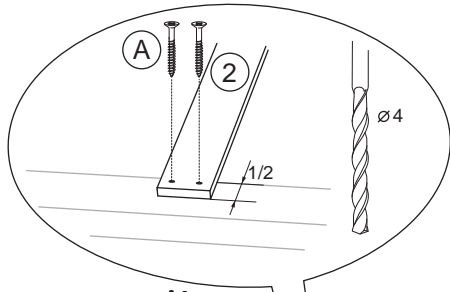
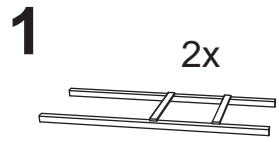

**4**

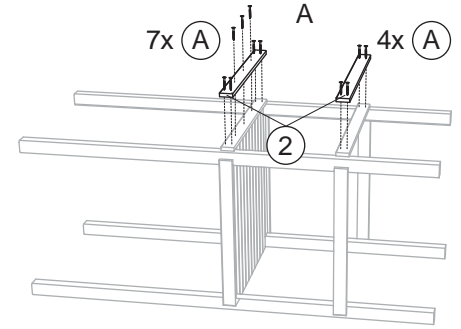

**5**

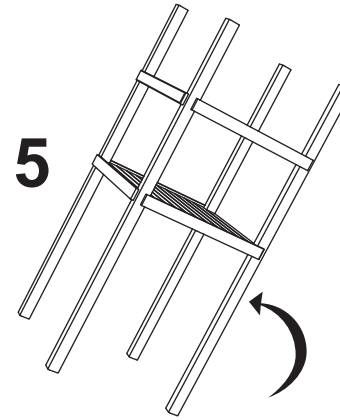

**2**

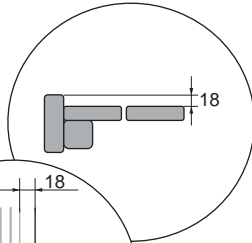
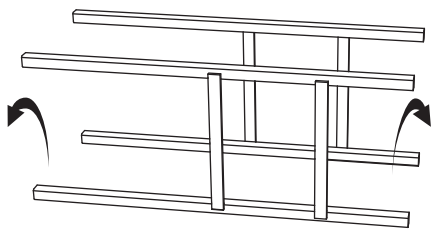

**3**

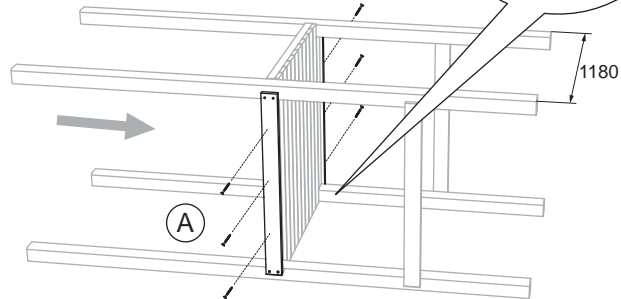
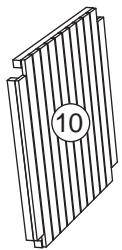

8x

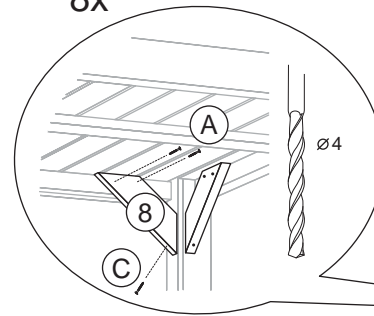

**6**

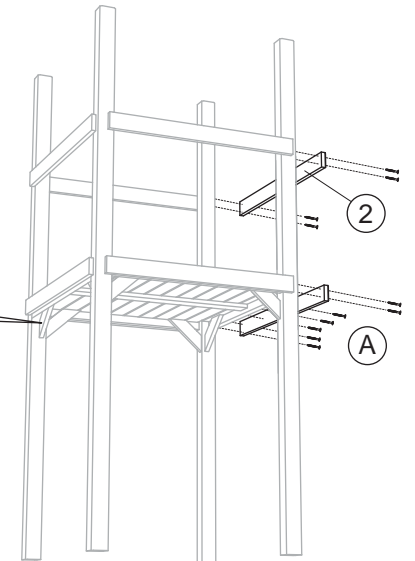



69245

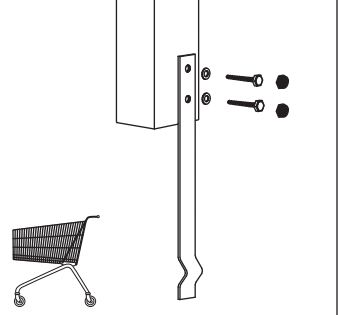

5900236692459

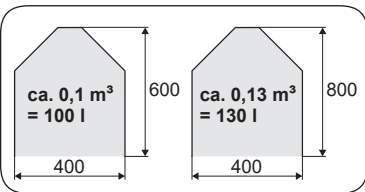
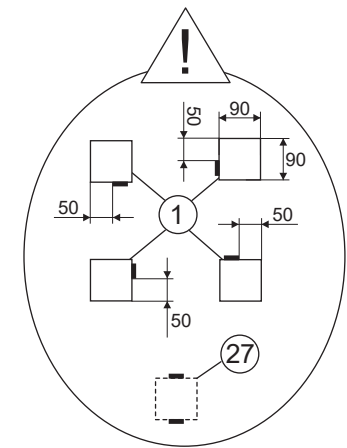
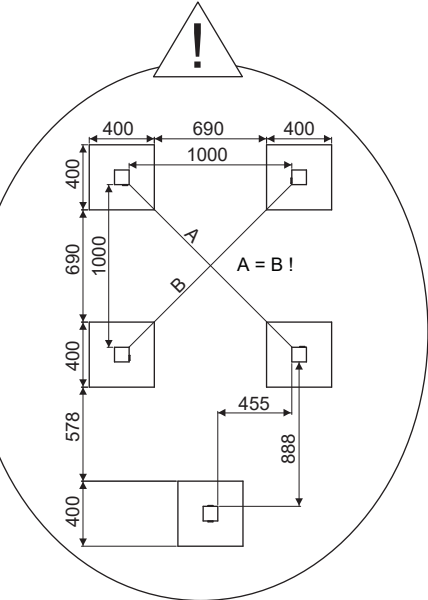
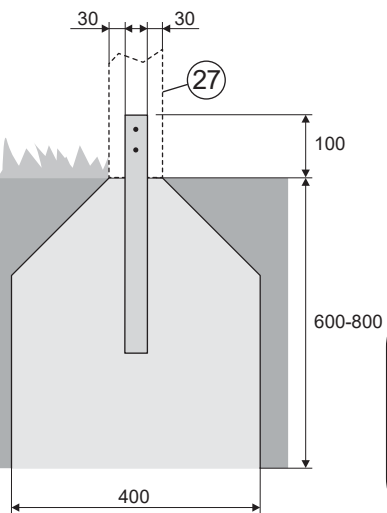
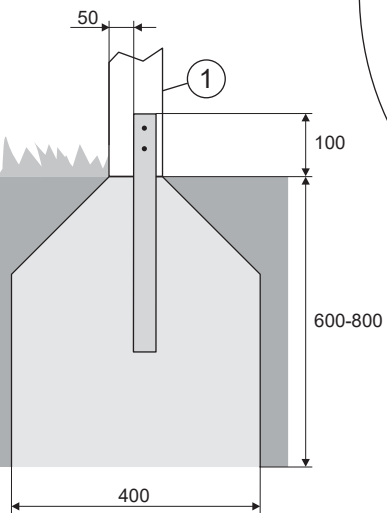

7

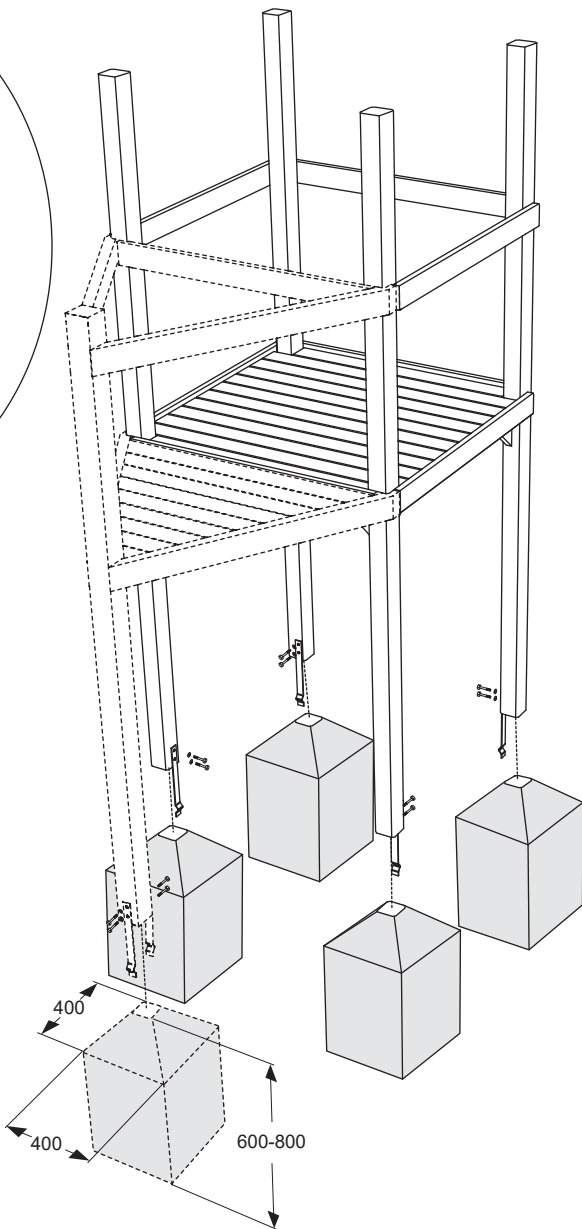

8

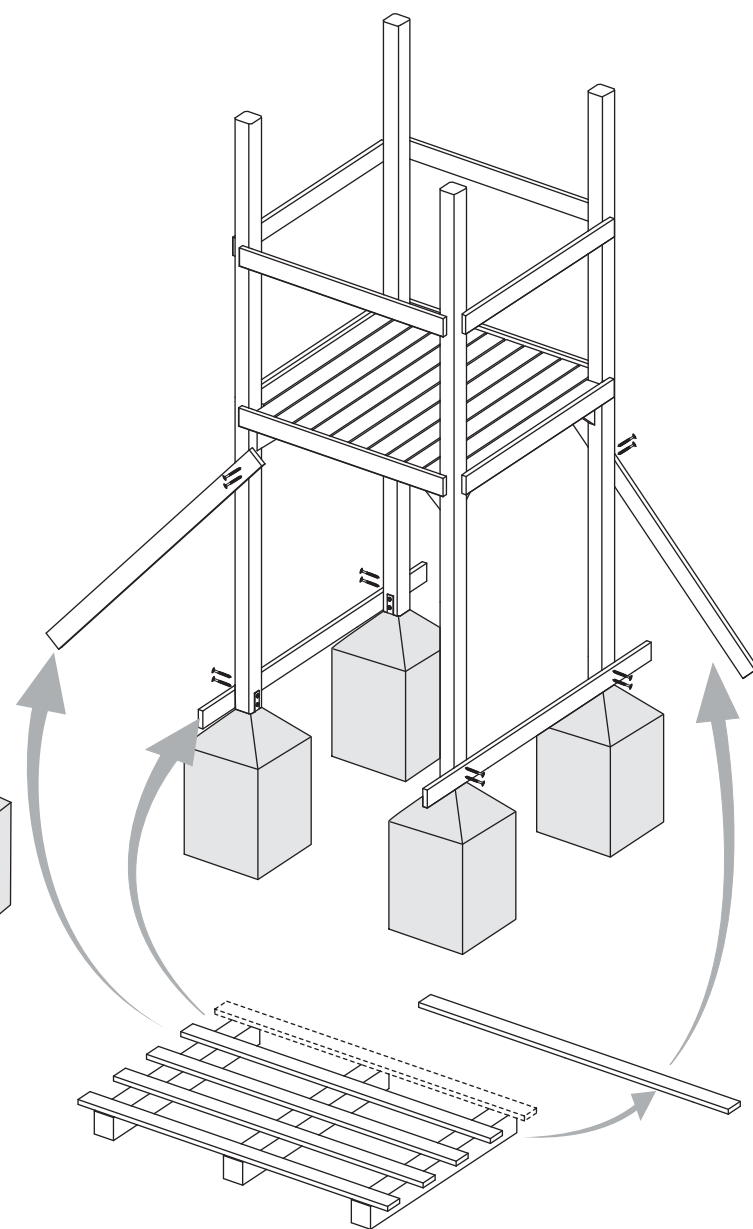

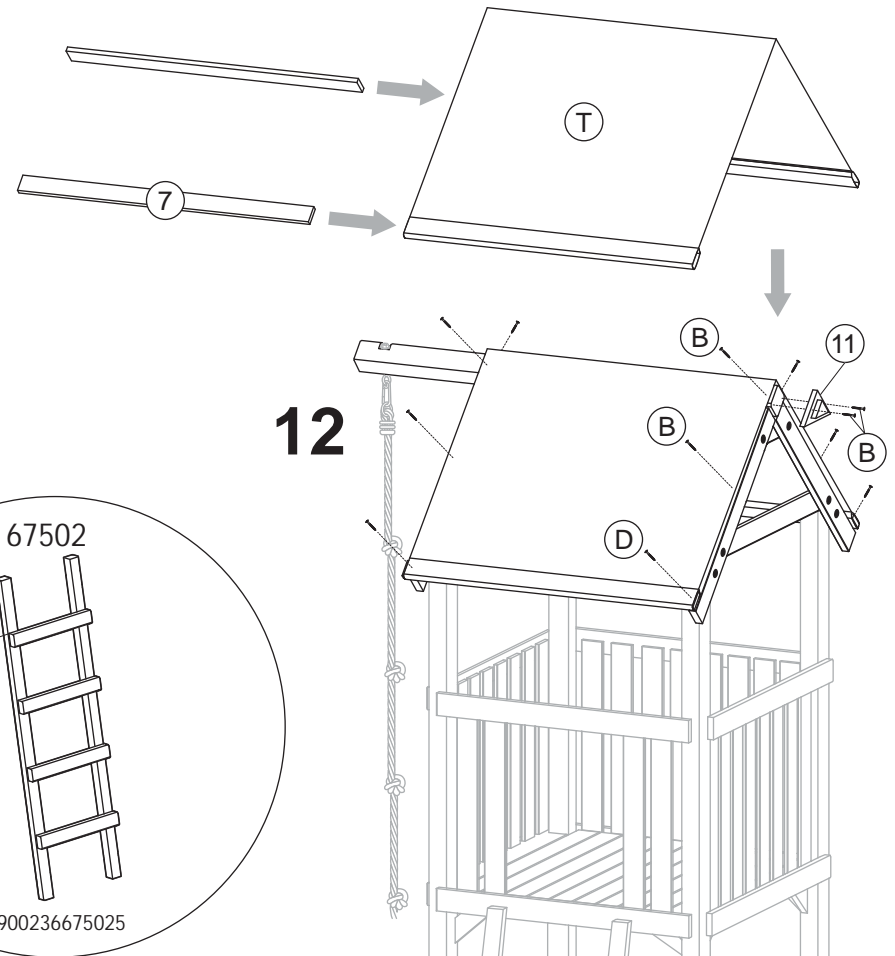
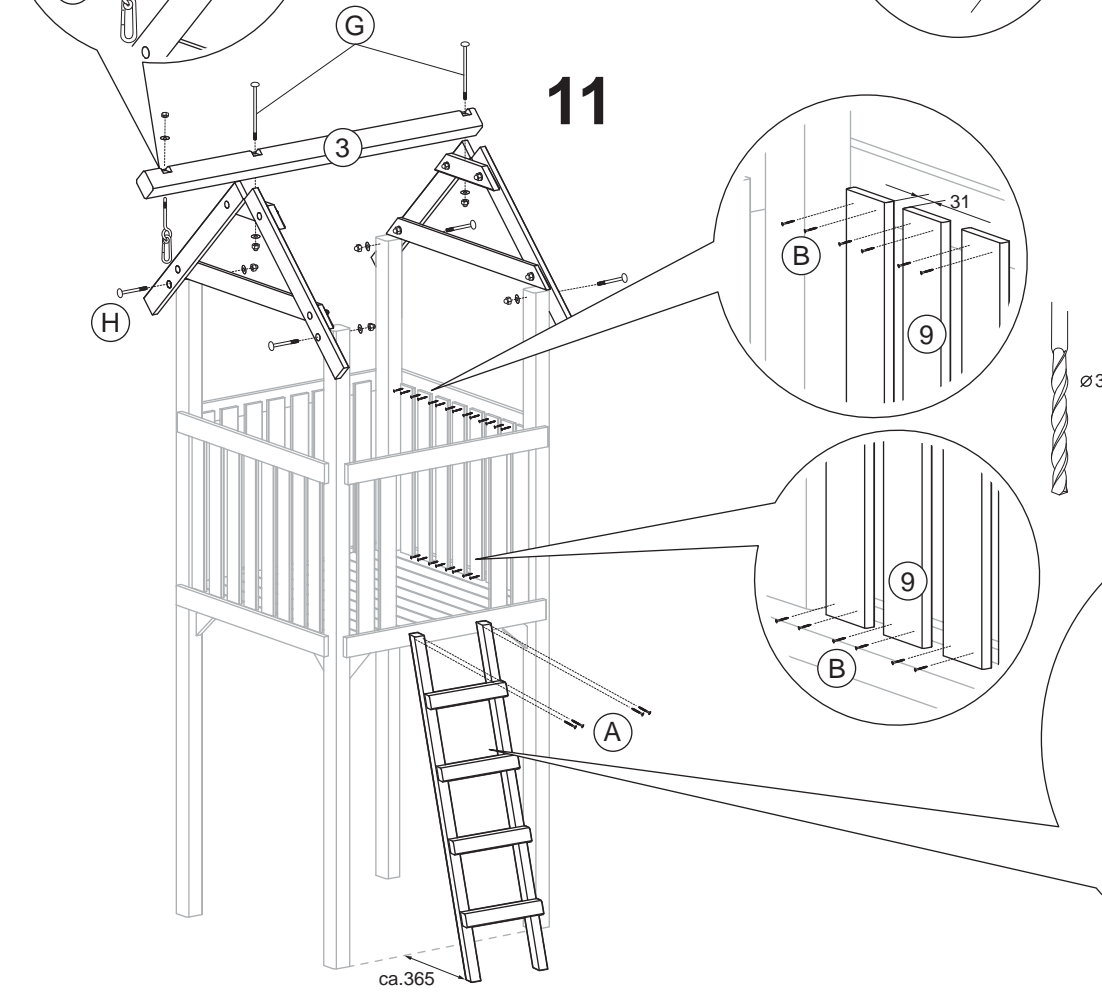
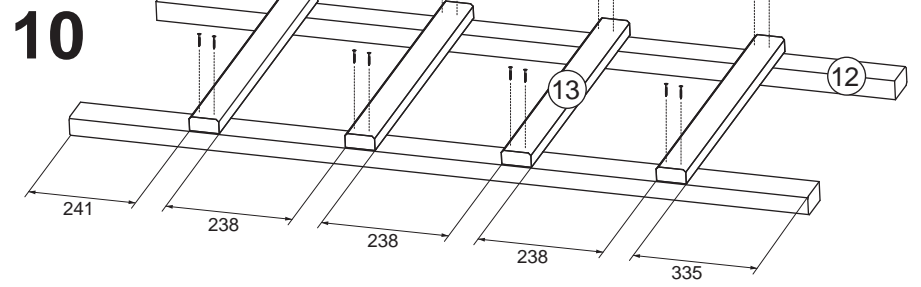
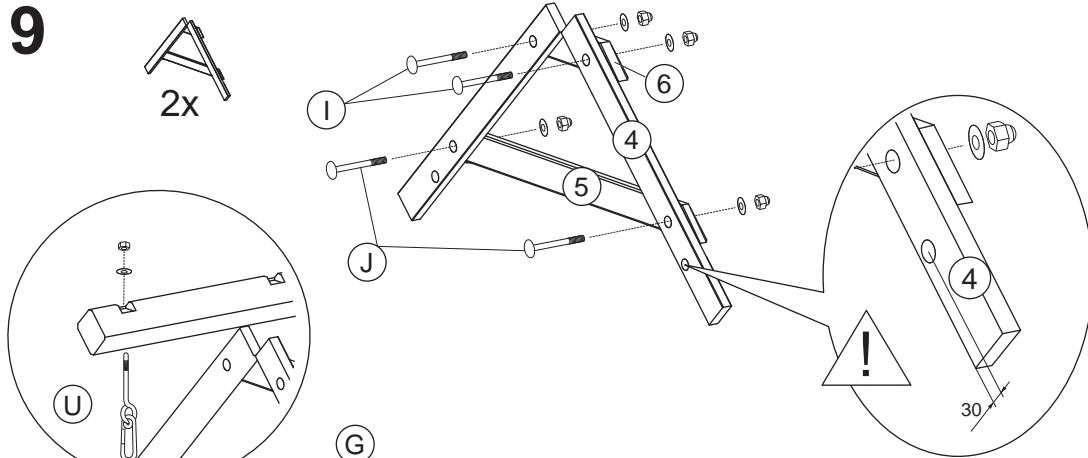

67501

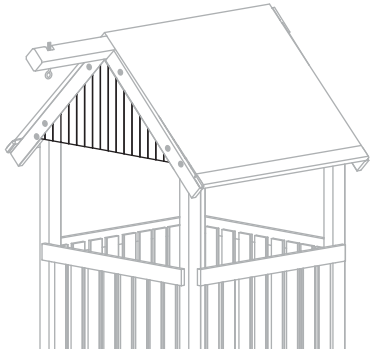

5900236675018



6x (D) - 4 x 60

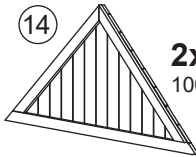

14

2x  
1000 x 500 x 28

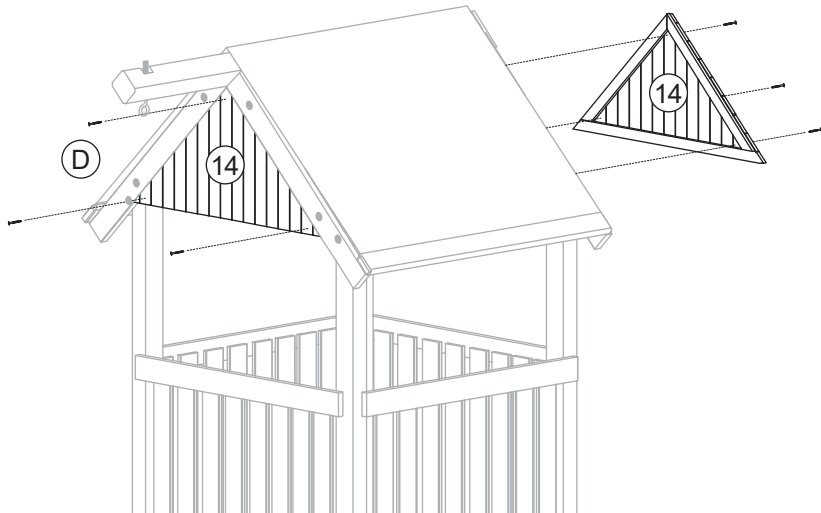

67503

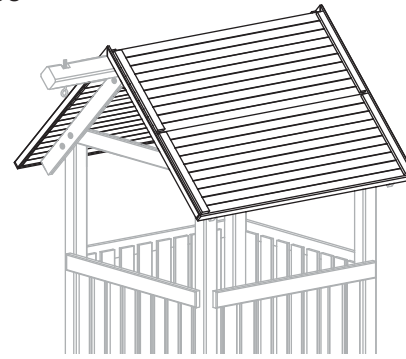

5900236675025

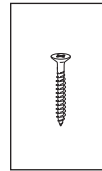

58x (E) - 4 x 50

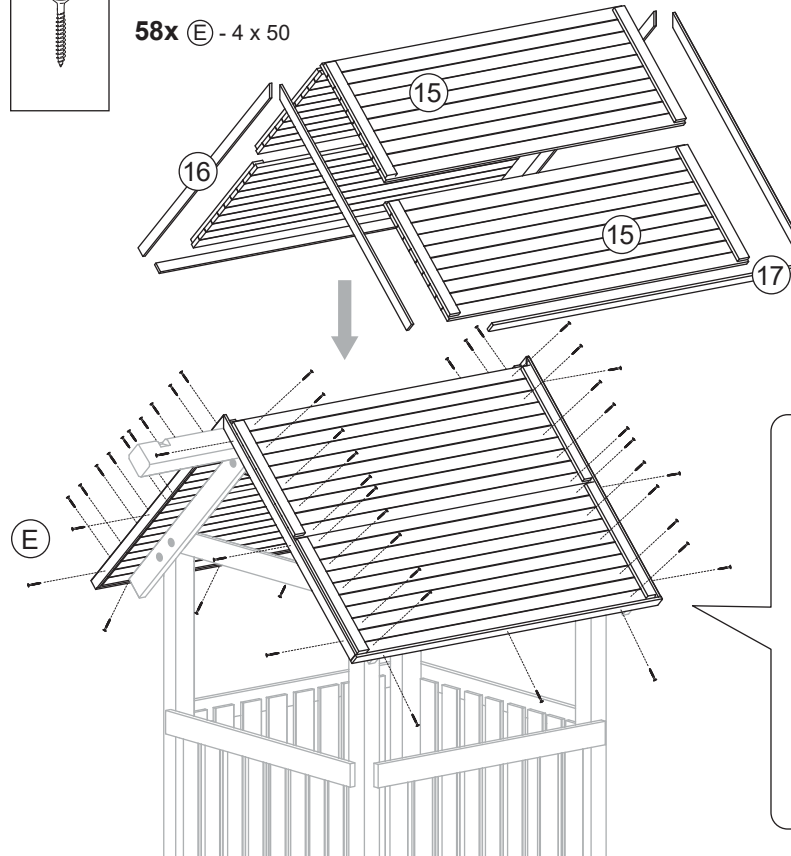

15

4x  
1470 x 520 x 14

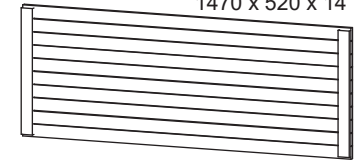

17

2x  
14 x 40 x 1470



16

4x  
14 x 40 x 1094

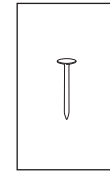

146x (F) - 2 x 15



69001 5900236690011  
69004 5900236690042

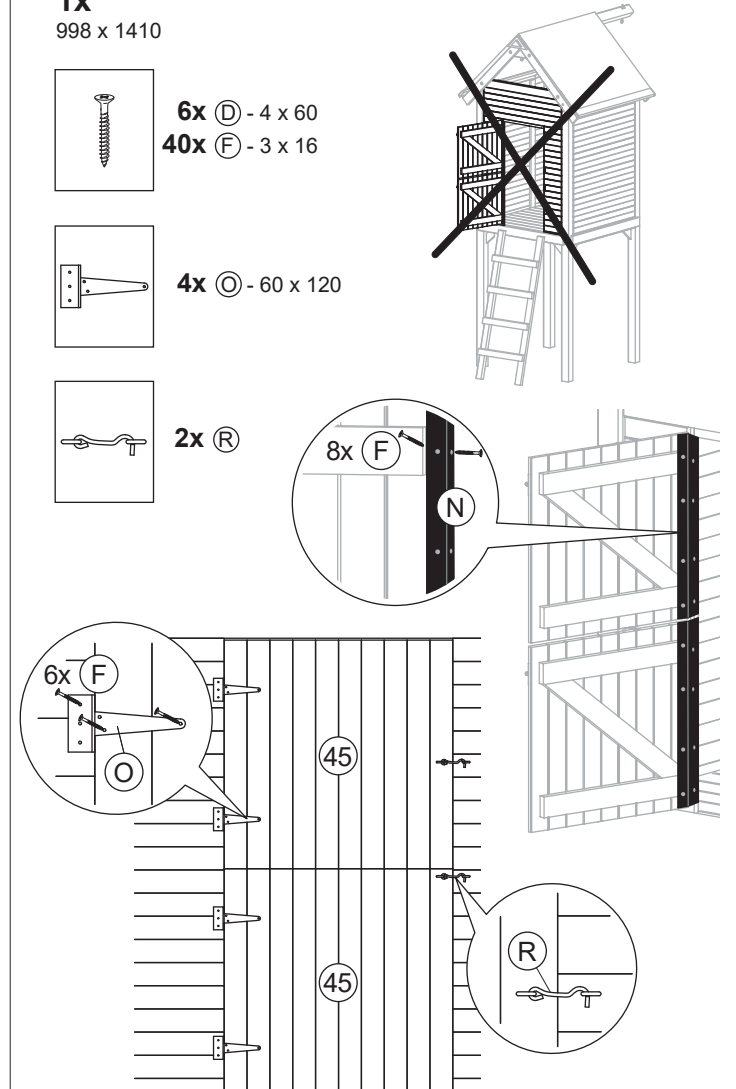
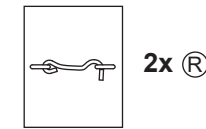
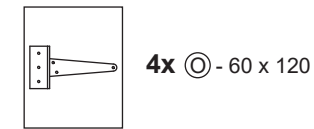
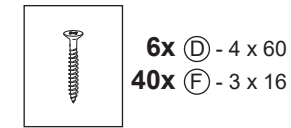
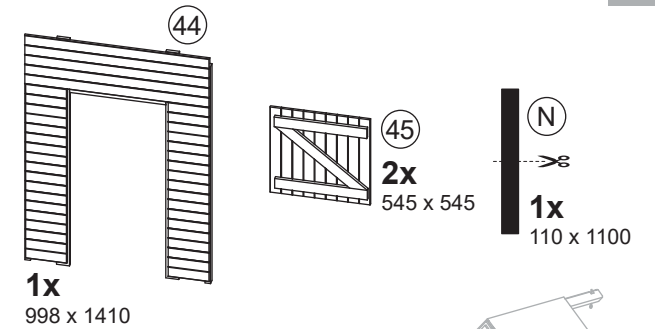
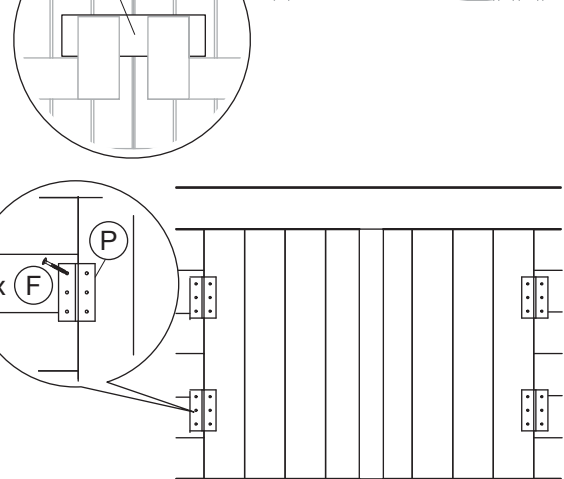
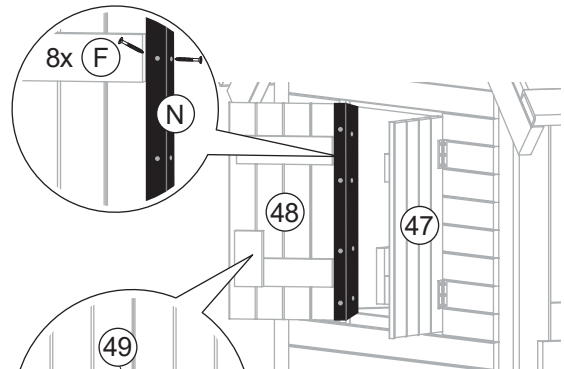
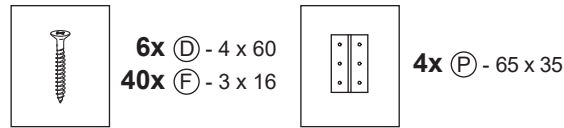
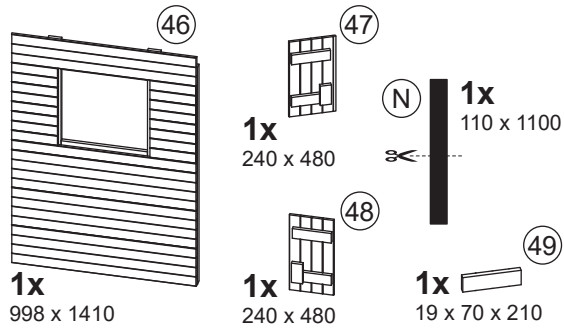
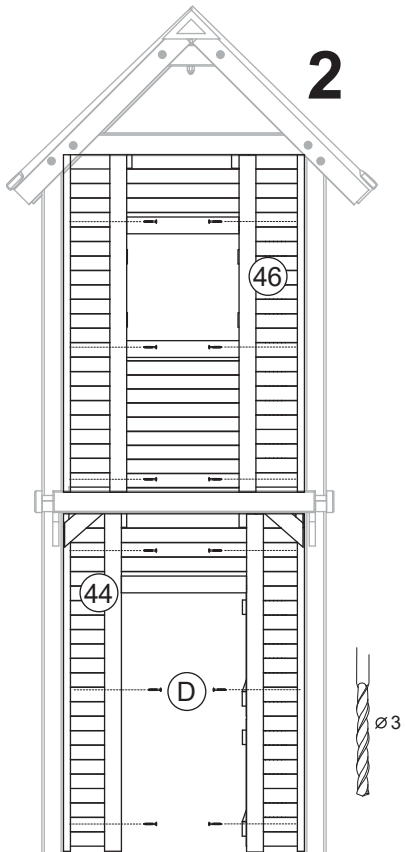
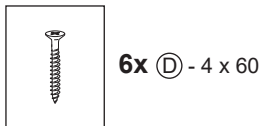
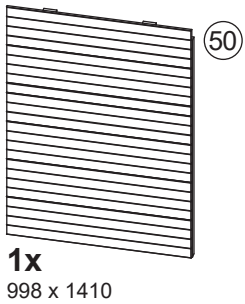
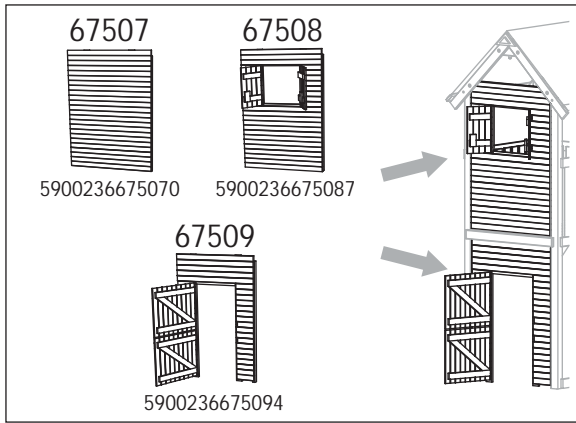

67511



5900236675117

- 9 **16x**  
16 x 90 x 763
- 2 **5x**  
30 x 90 x 1090
- 30 **1x**  
1090 x 1180
- 8 **6x**  
40 x 90 x 340
- 27 **2x**  
90 x 90 x 2400



- 50x** (A) - 5 x 70
- 64x** (B) - 3,5 x 35
- 6x** (C) - 5 x 120

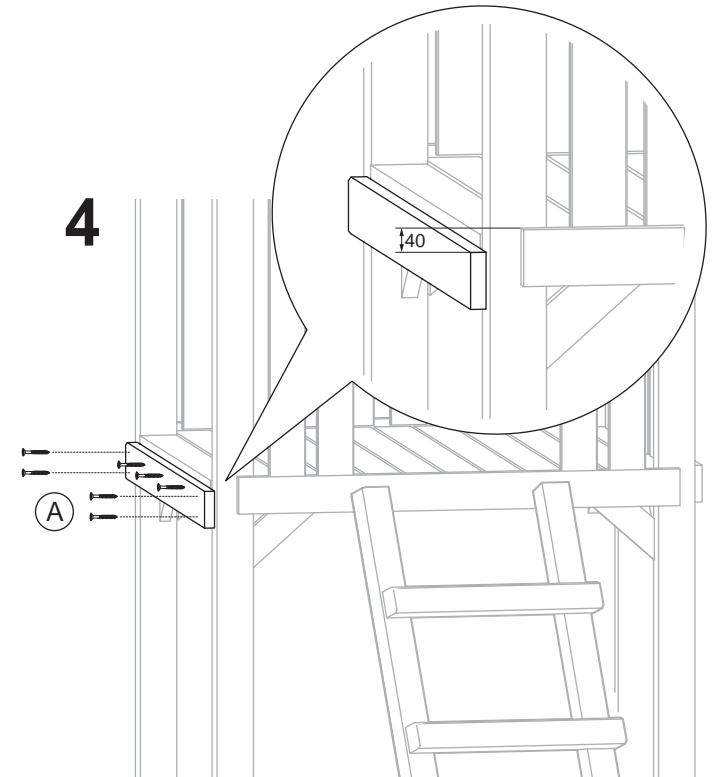
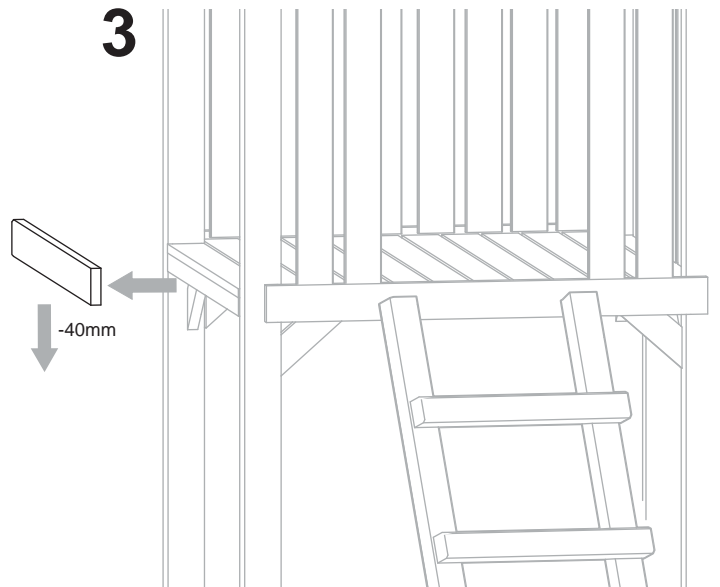
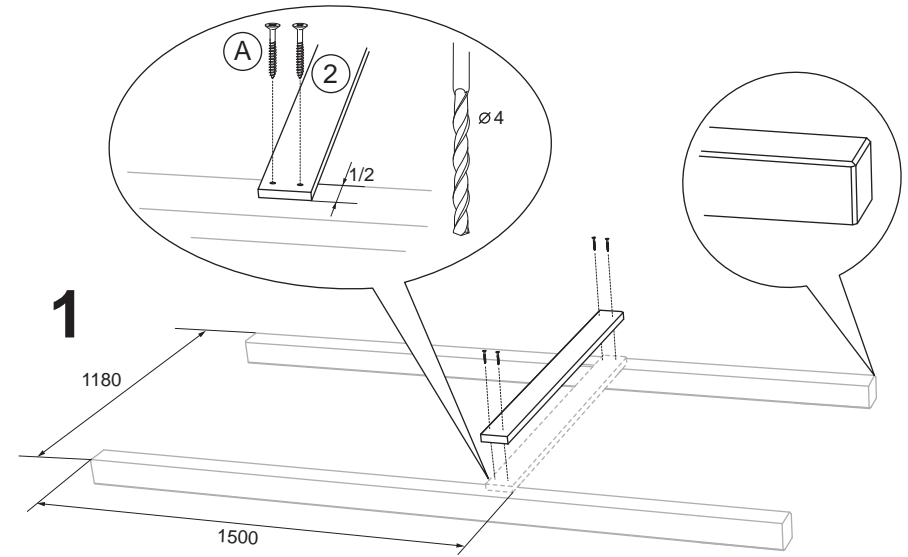

5

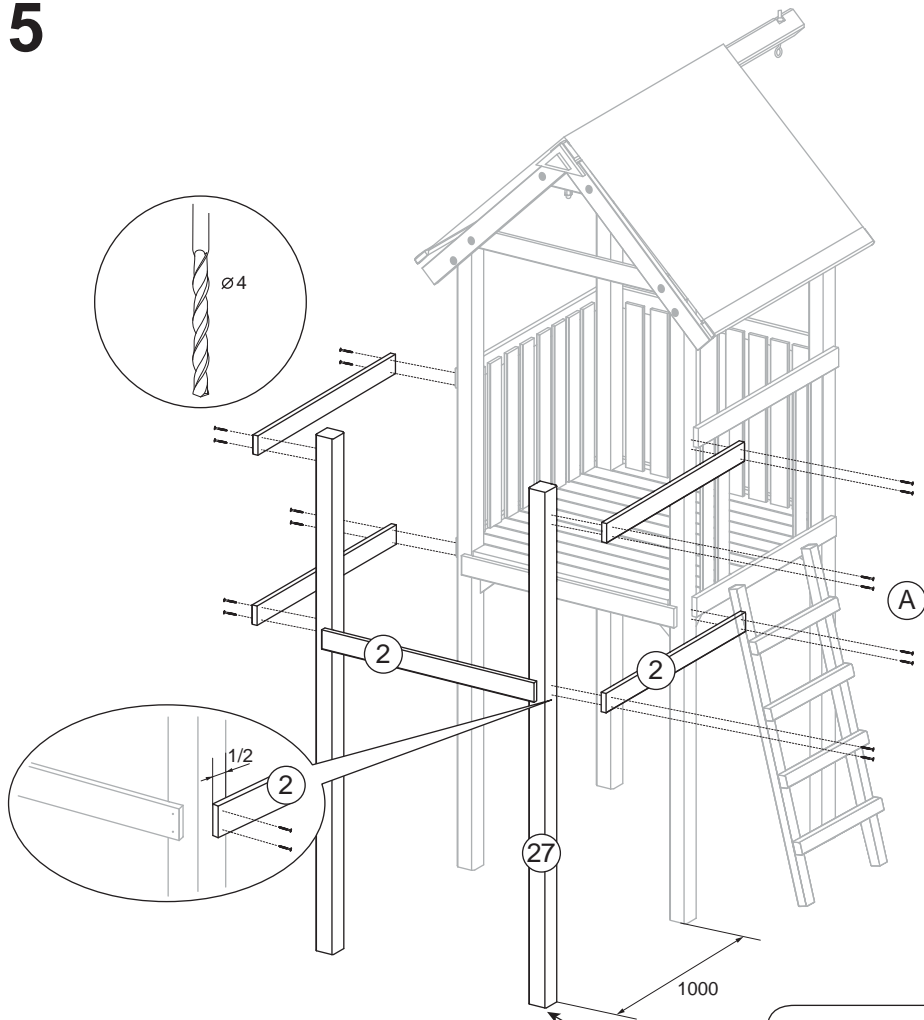

6

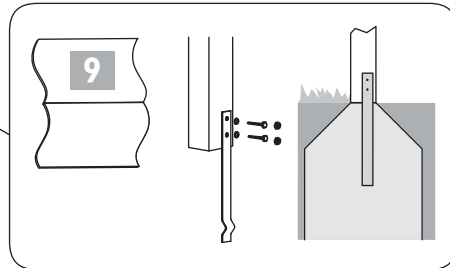
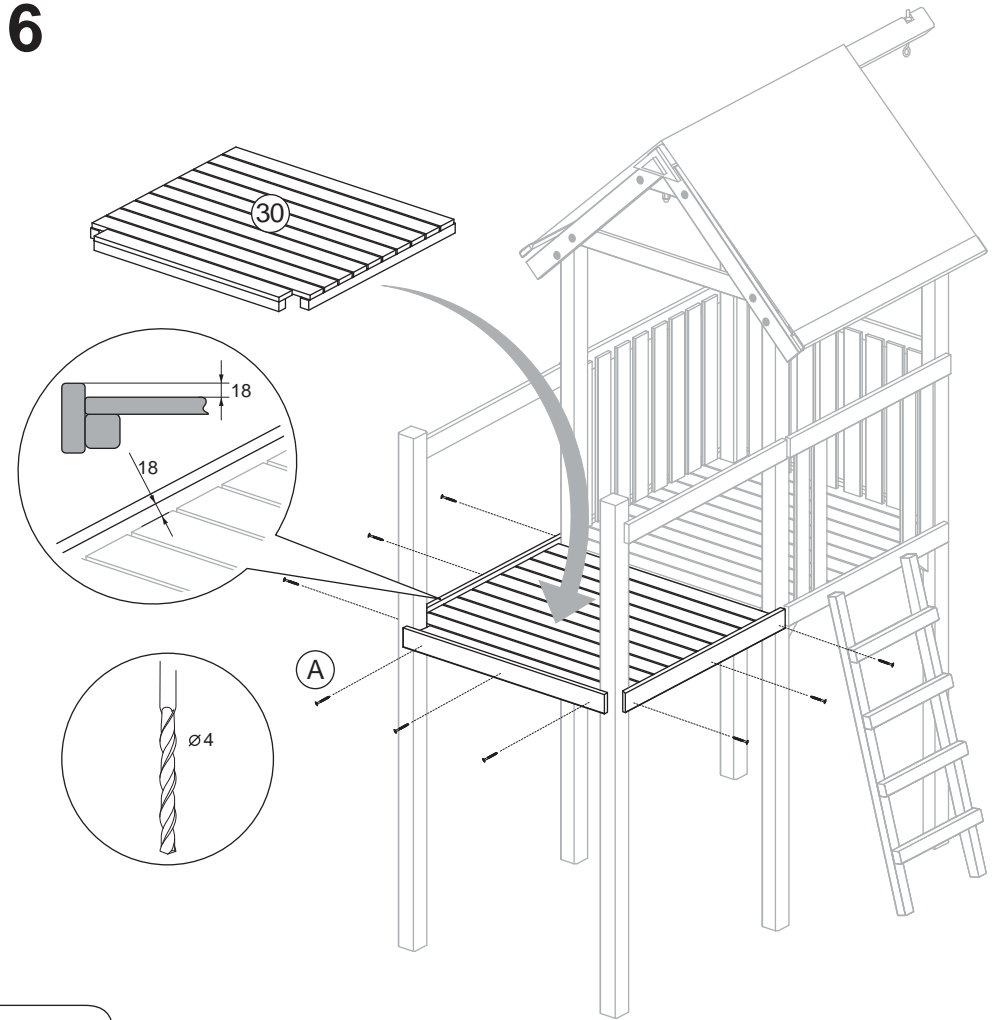

7

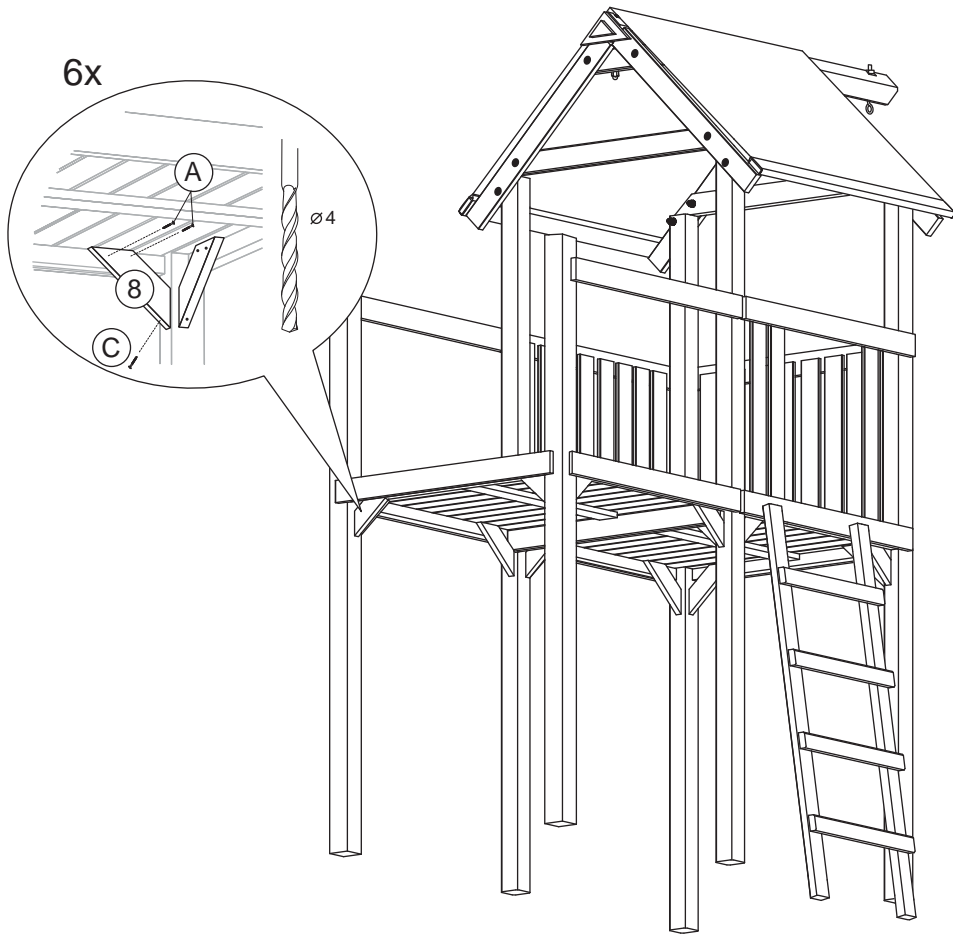

8



67513



5900236675131

**DELTA**  
GARTENHOLZ

16

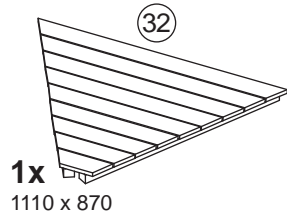

**1x**  
1110 x 870



**16x**  
16 x 90 x 763

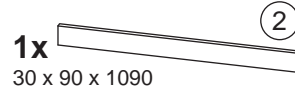

**1x**  
30 x 90 x 1090

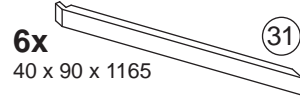

**6x**  
40 x 90 x 1165

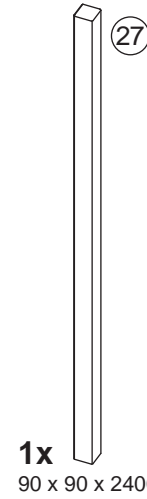

**1x**  
90 x 90 x 2400



1



**35x** (A) - 5 x 70  
**64x** (B) - 3,5 x 35

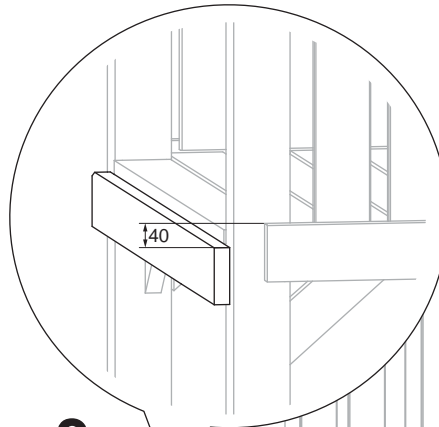

2

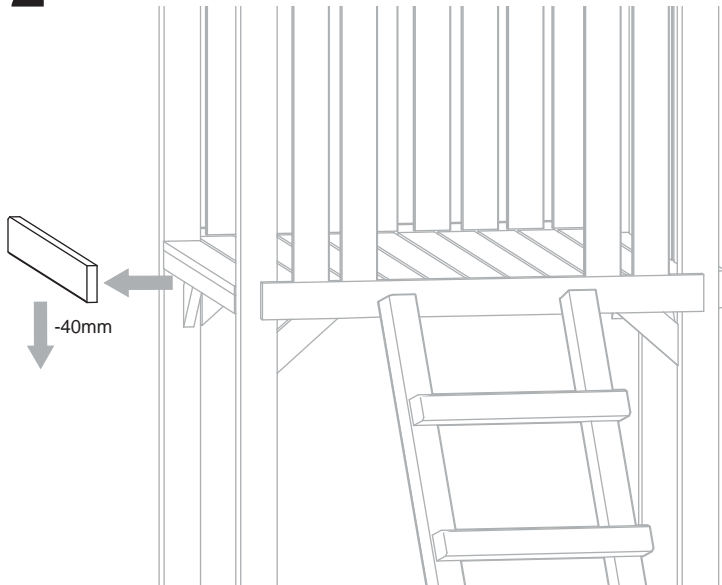

3

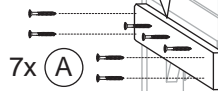

7x (A)

4

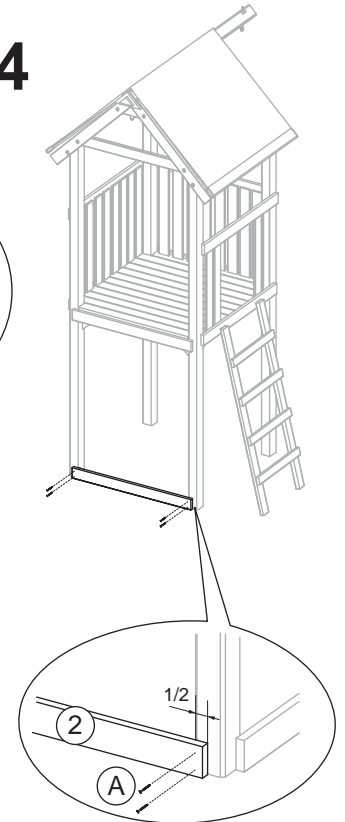
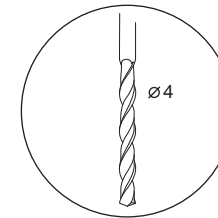



5

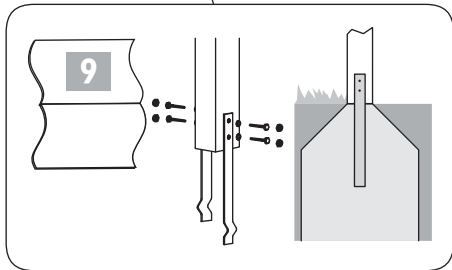
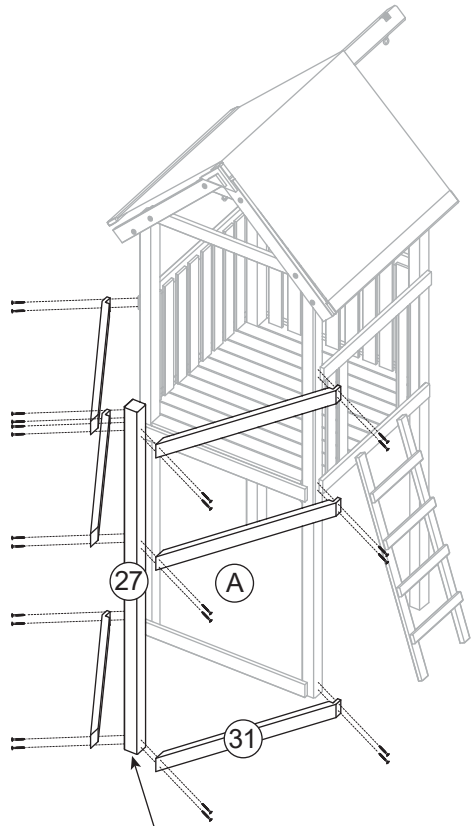

6

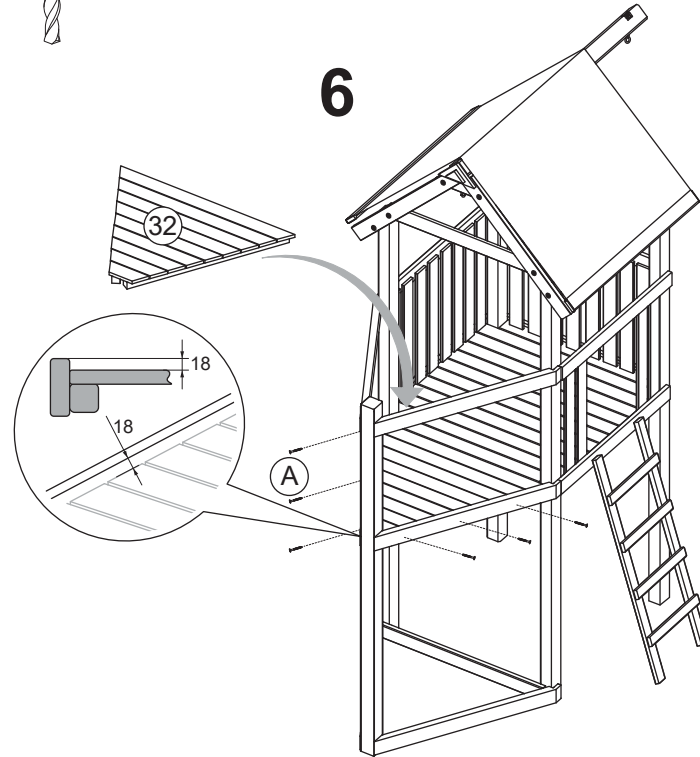

7

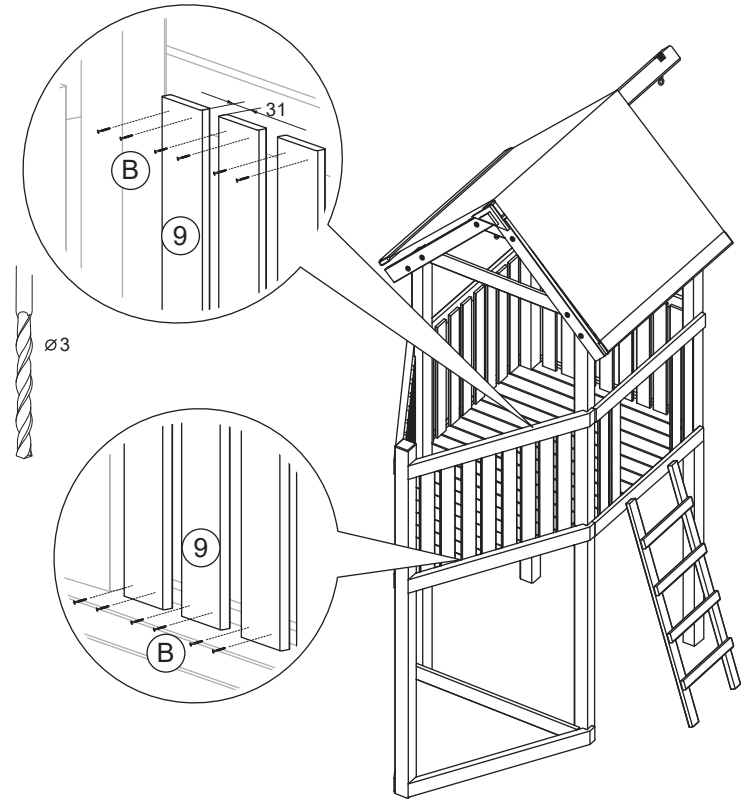

67514

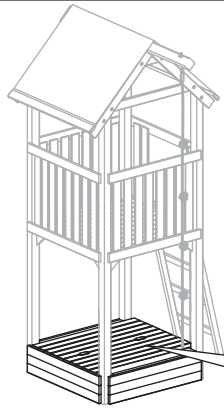

5900236675148



**12x** 30 x 90 x 1090 (2)

**2x** 20 x 120 x 1000 (33)

67515

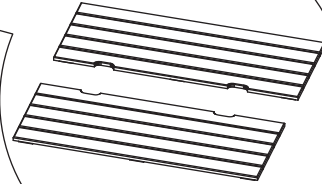

5900236675155



**48x** (A) - 5 x 70  
**8x** (D) - 4 x 60

67516



5900236675162

18

**2x** 30 x 90 x 1090 (2)

**4x** 40 x 90 x 1165 (31)

67517

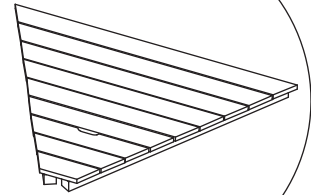

5900236675179



**24x** (A) - 5 x 70

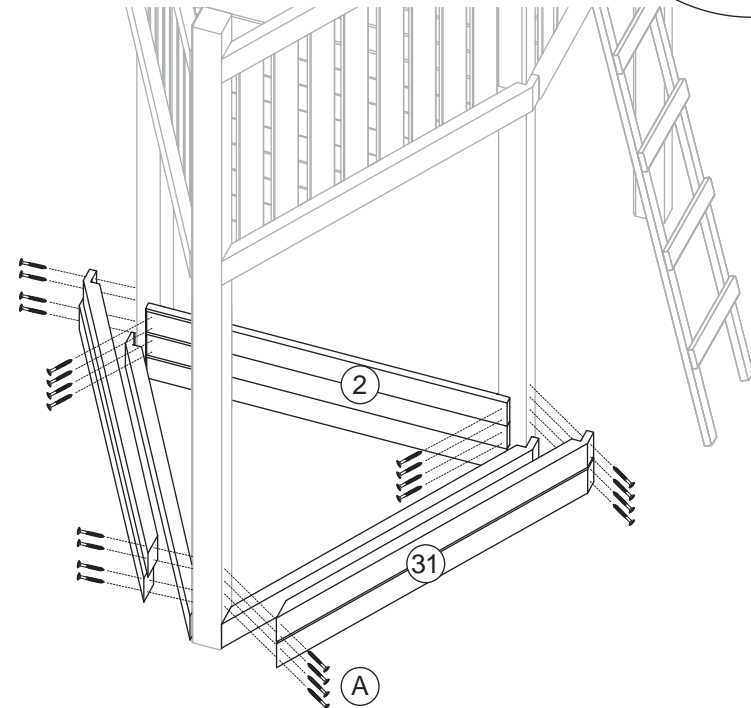
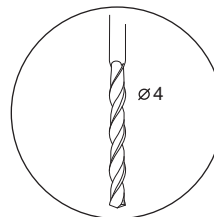
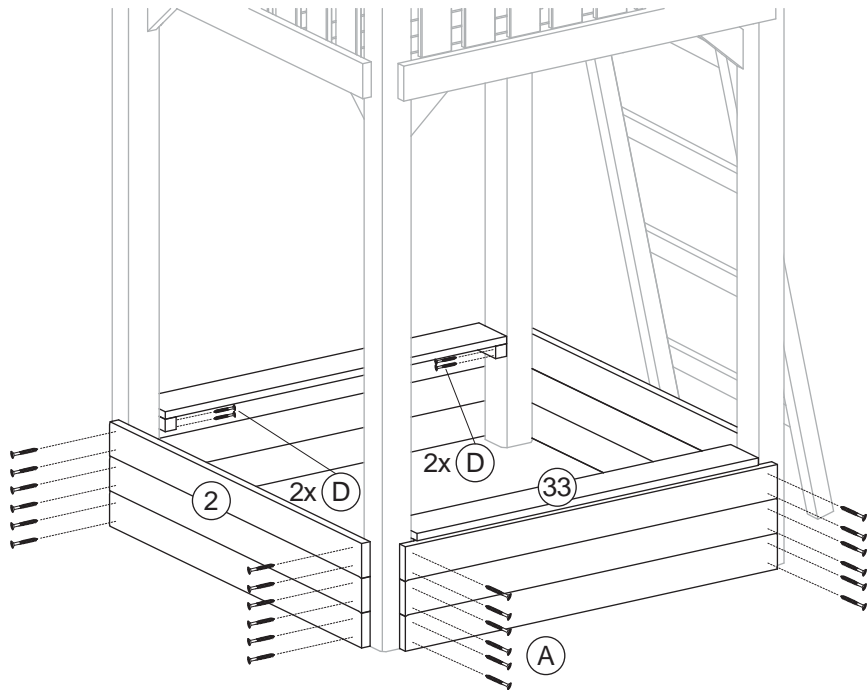

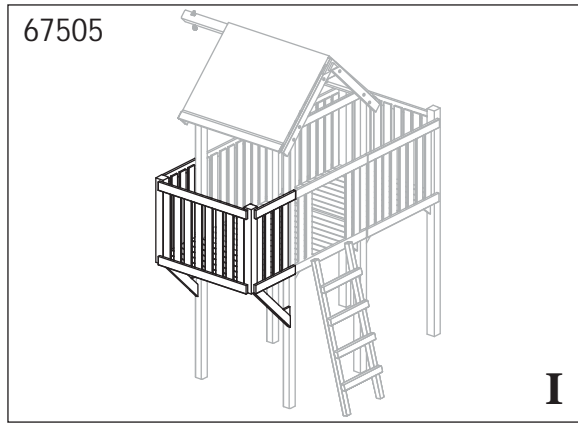

5900236675056

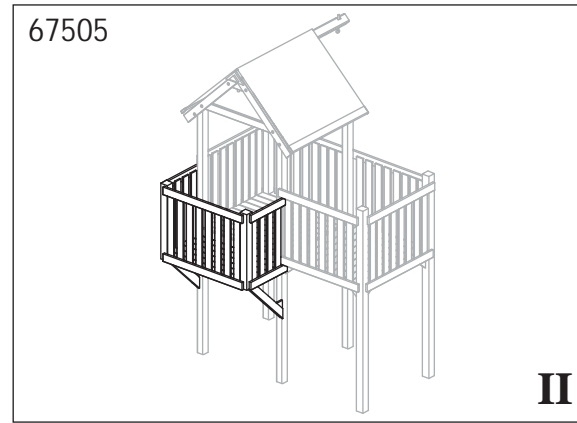

5900236675056



- 40x (A) - 5 x 70
- 64x (B) - 3,5 x 35
- 2x (C) - 5 x 120

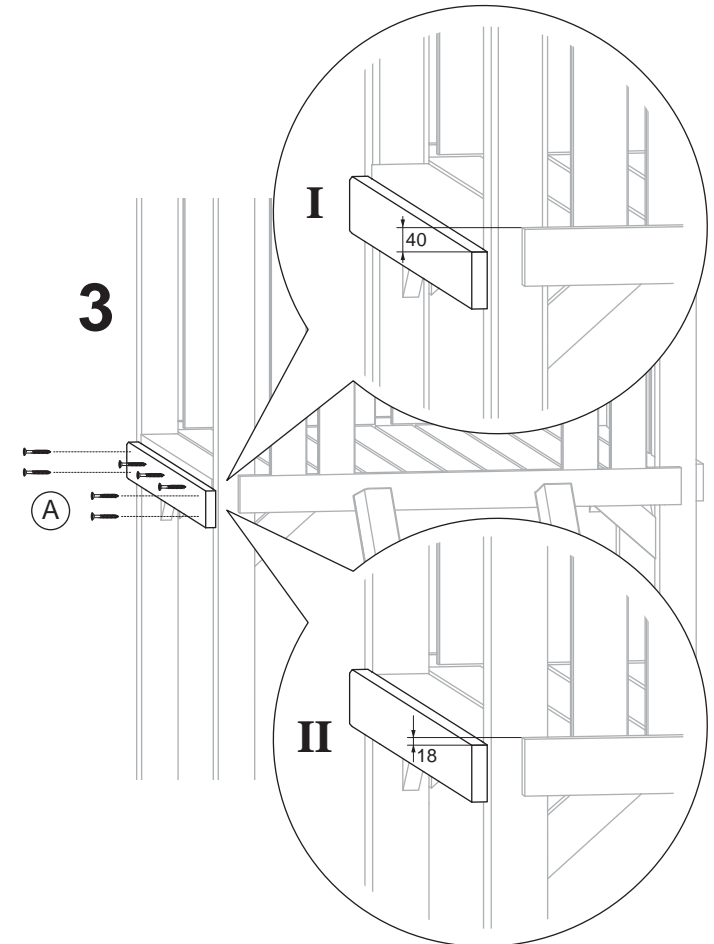
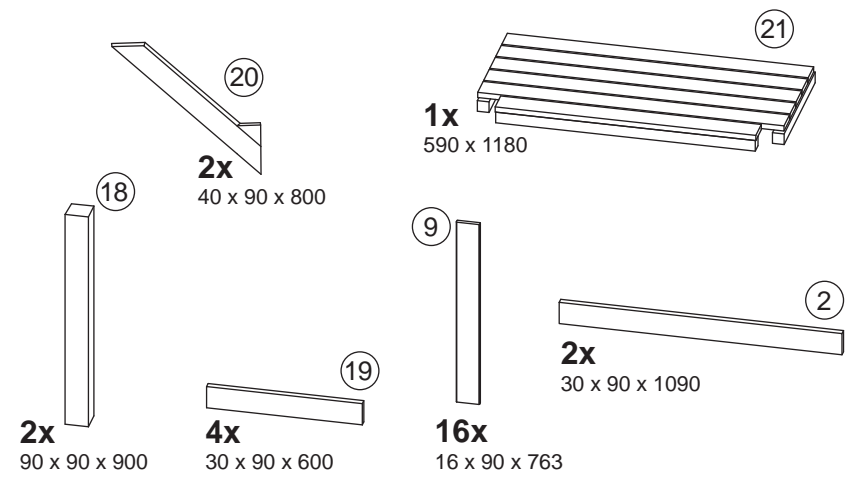
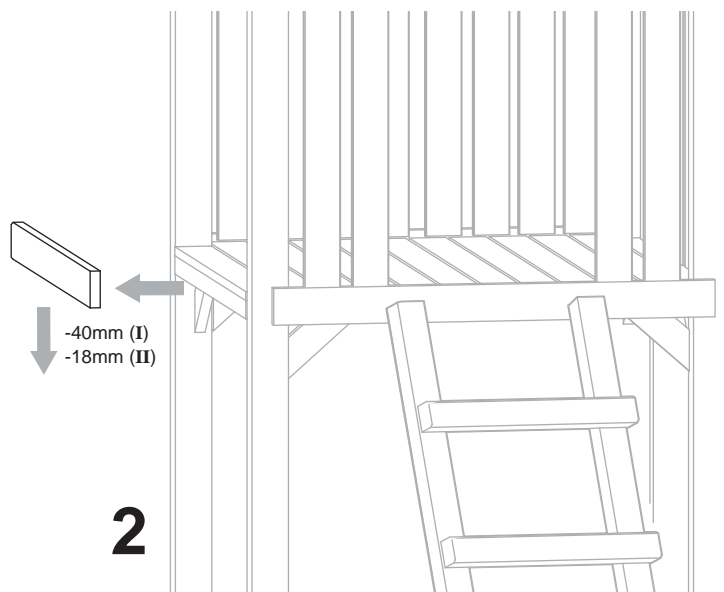

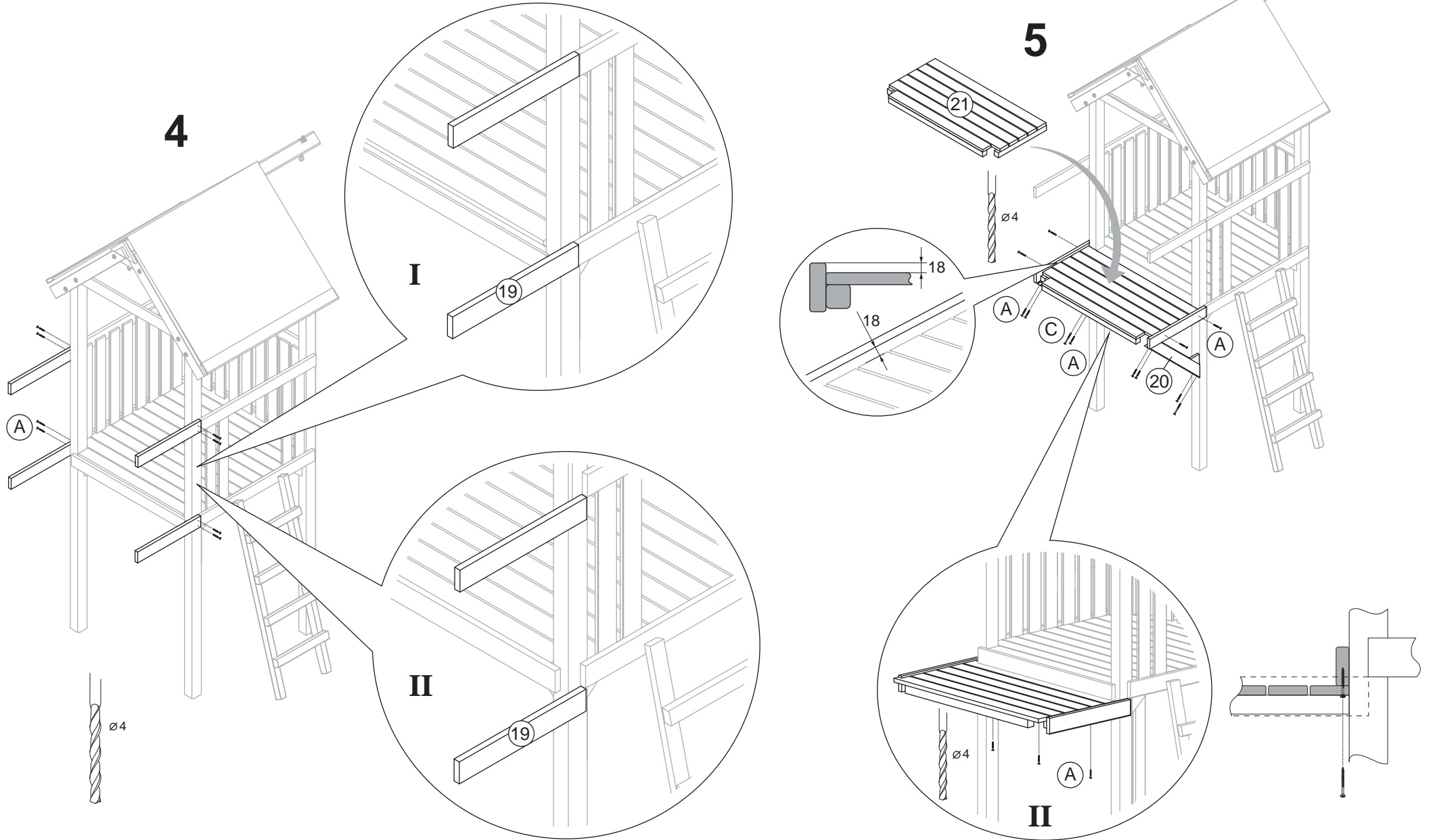

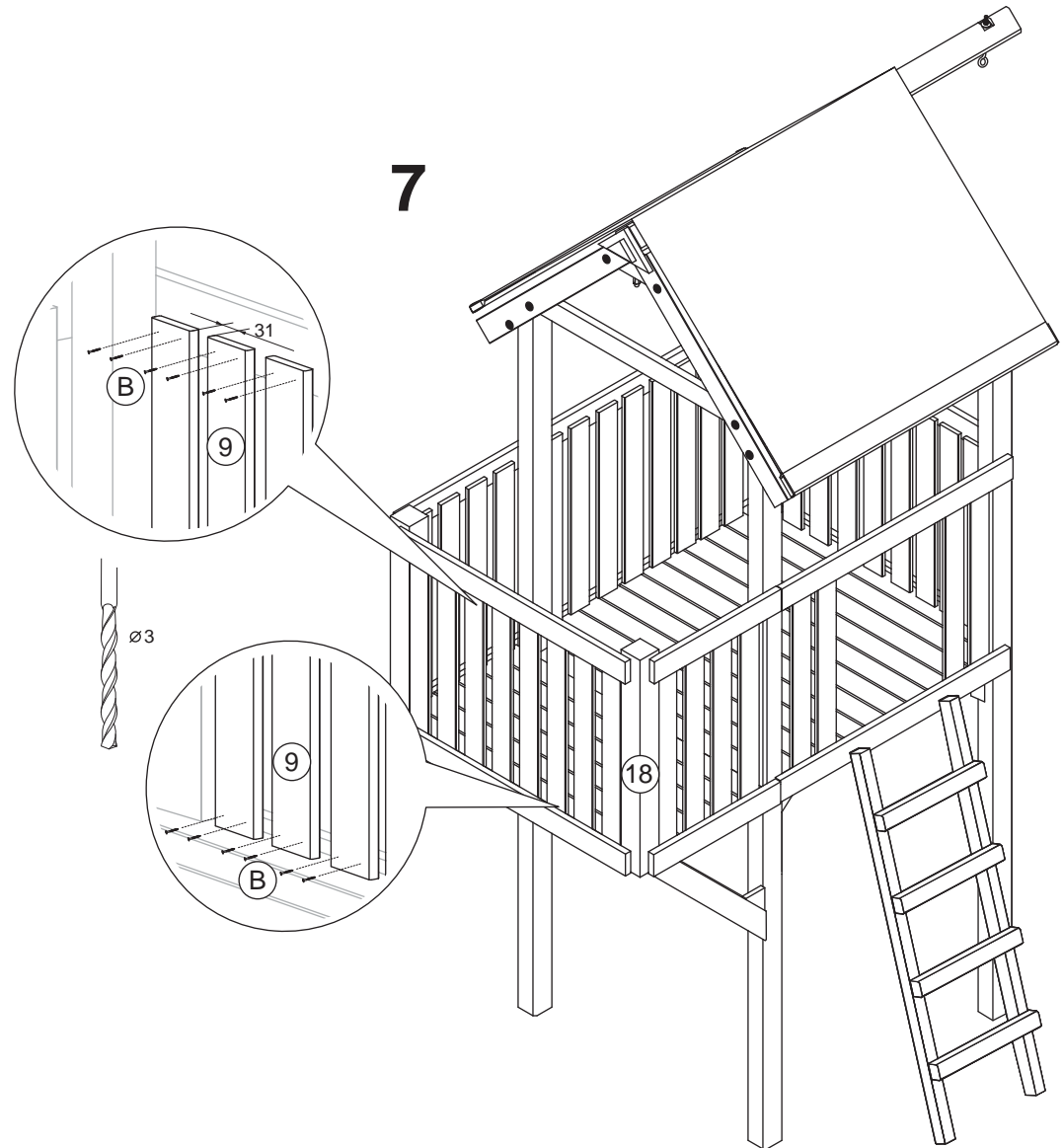
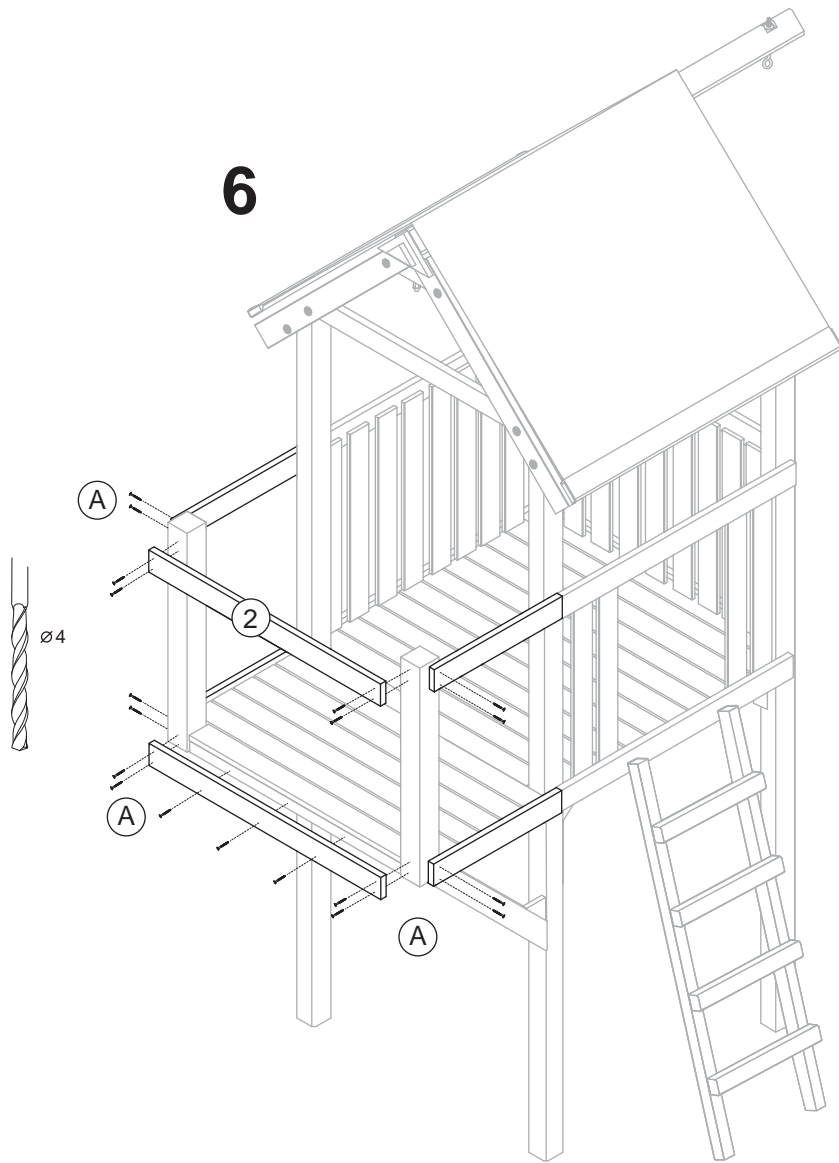

67506



5900236675063

**4x**  
30 x 90 x 1800 (22)

**17x**  
22 x 90 x 1180 (25)

**2x**  
45 x 45 x 1710 (23)

**28x**  
16 x 90 x 763 (9)

**4x**  
40 x 90 x 500 (26)

**2x**  
45 x 45 x 1650 (24)

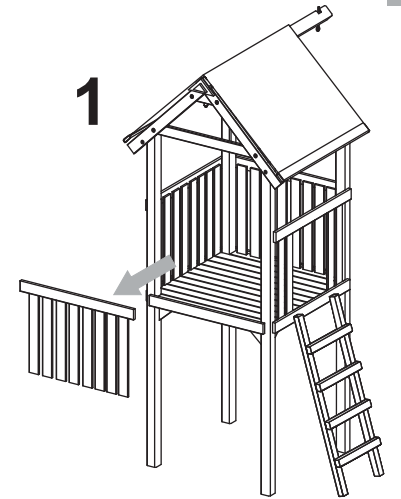

- 44x** (A) - 5 x 70
- 112x** (B) - 3,5 x 35
- 4x** (C) - 5 x 120
- 136x** (D) - 4 x 60

**2**

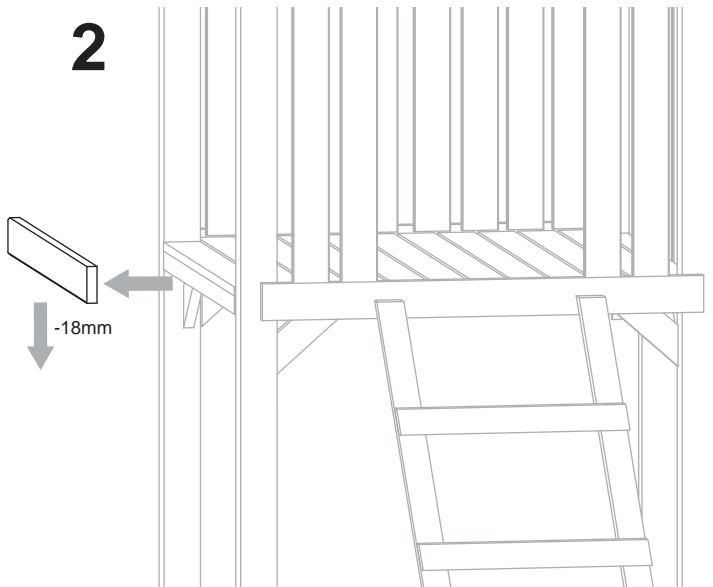

**3**

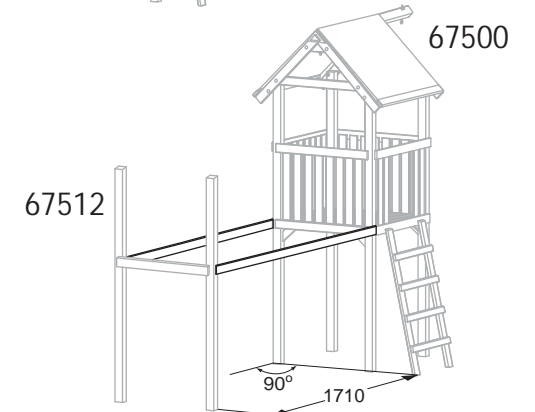
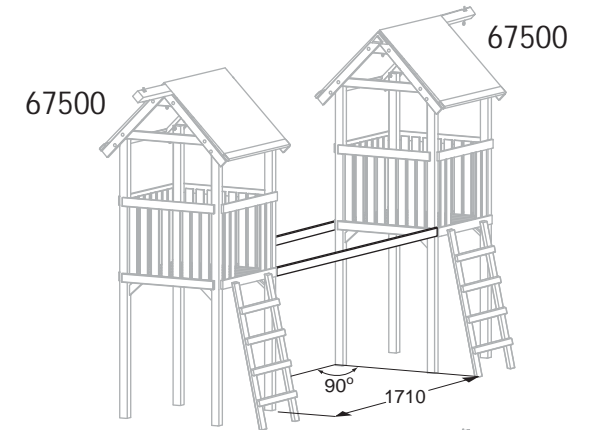
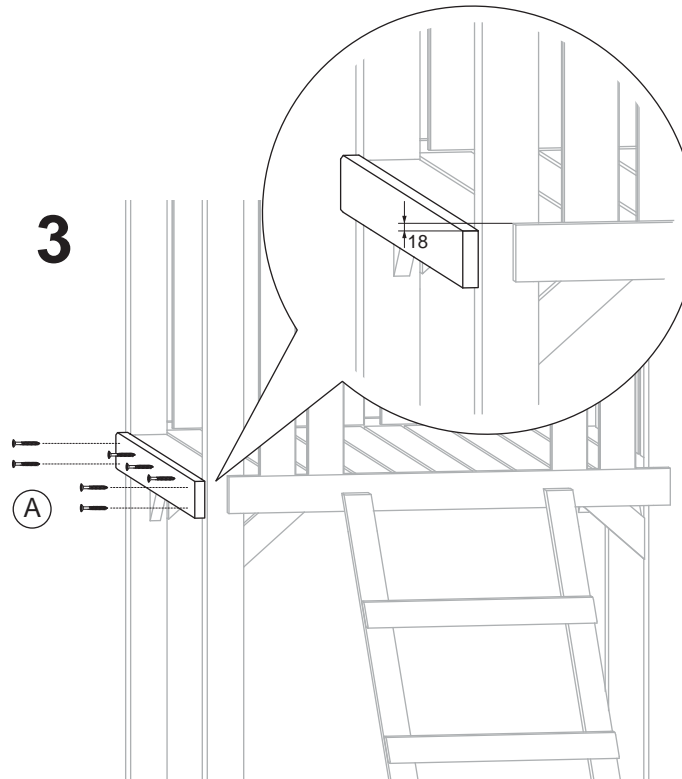

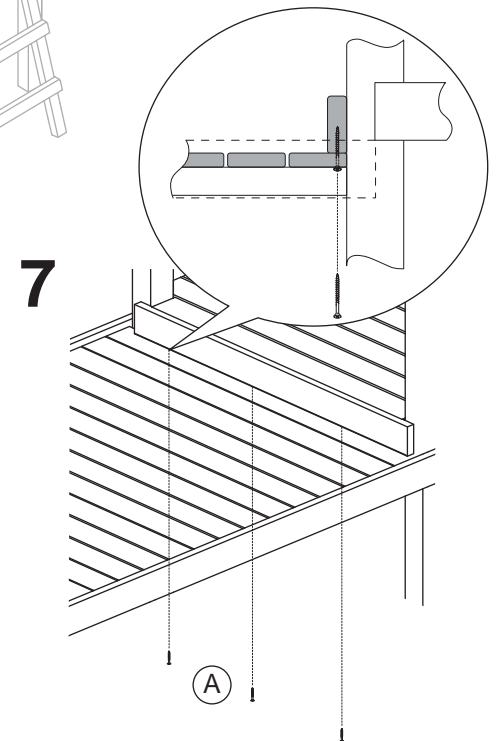
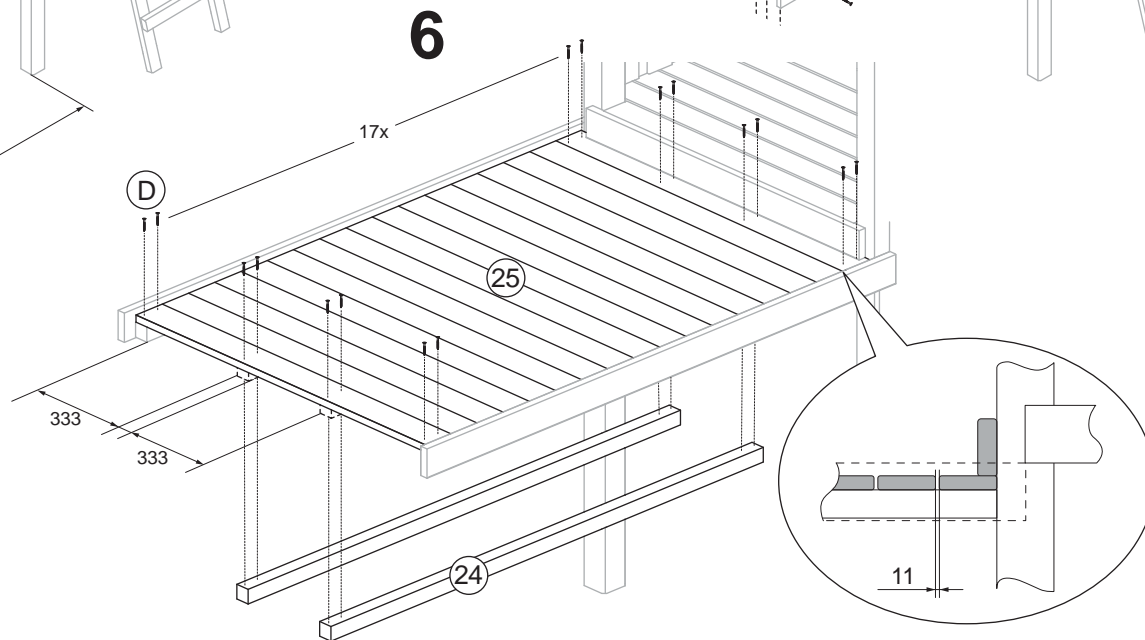
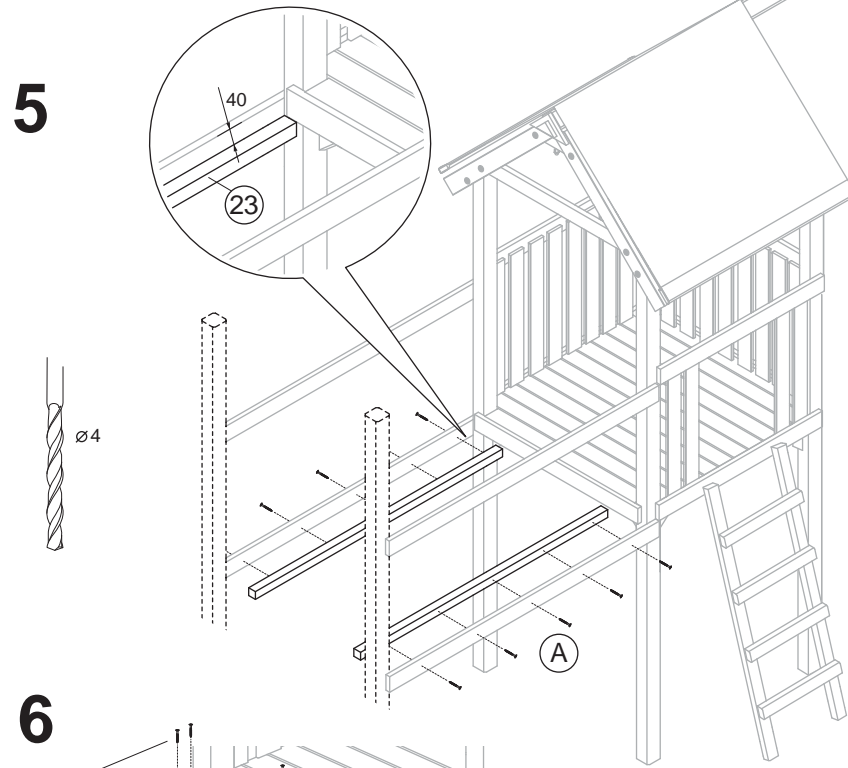
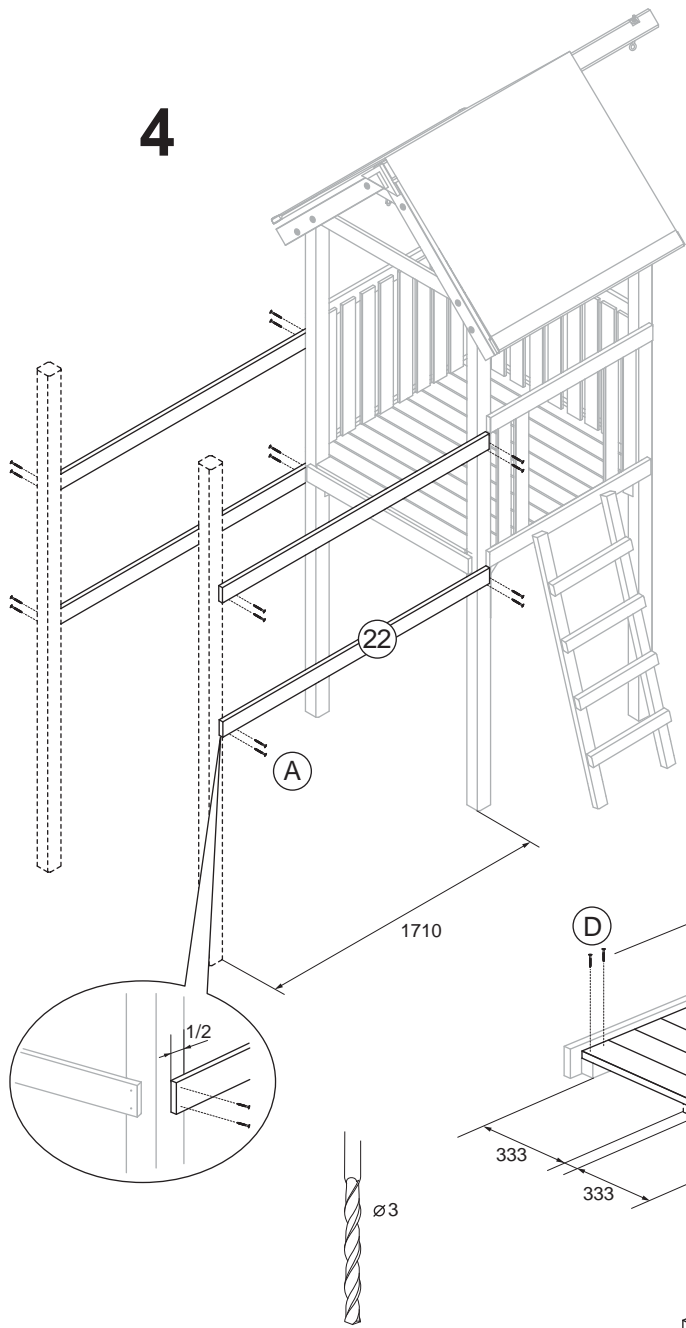

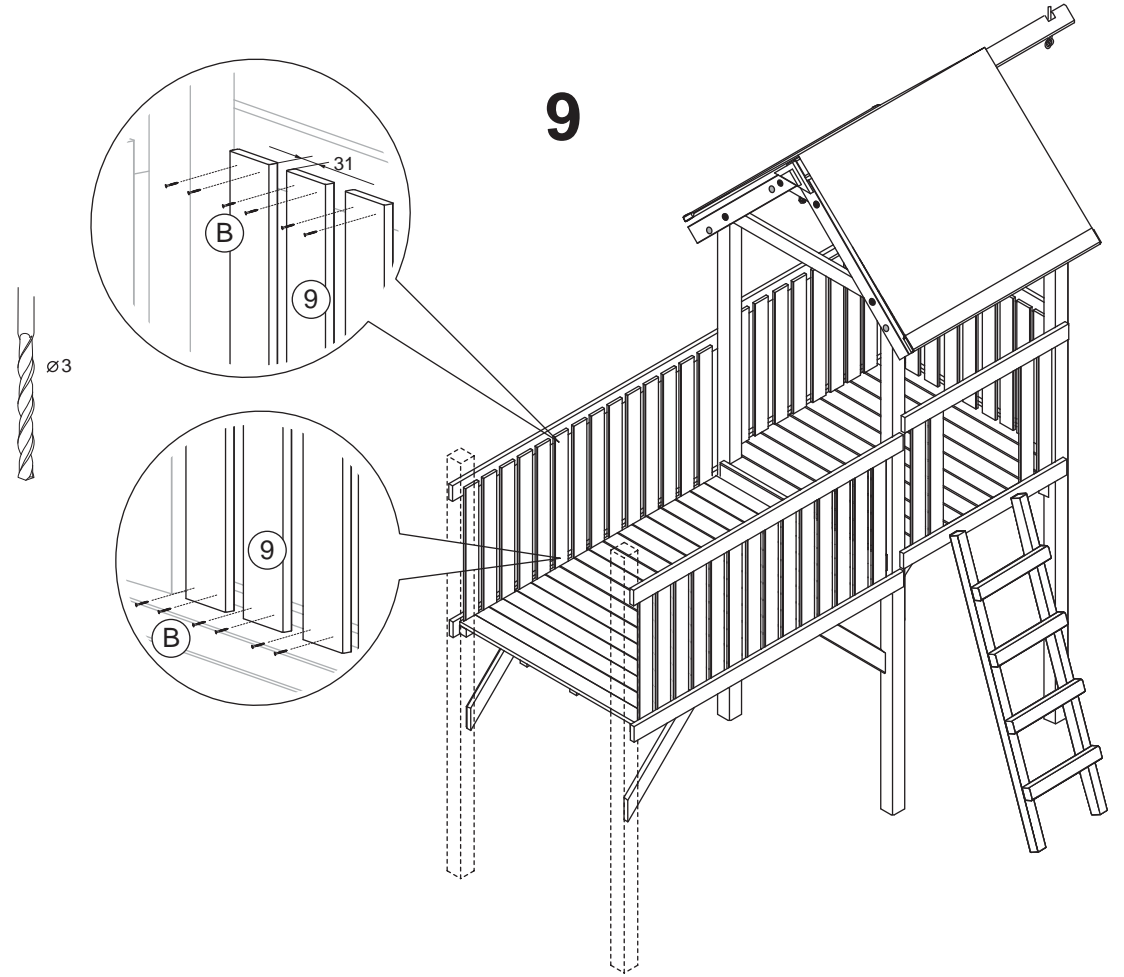
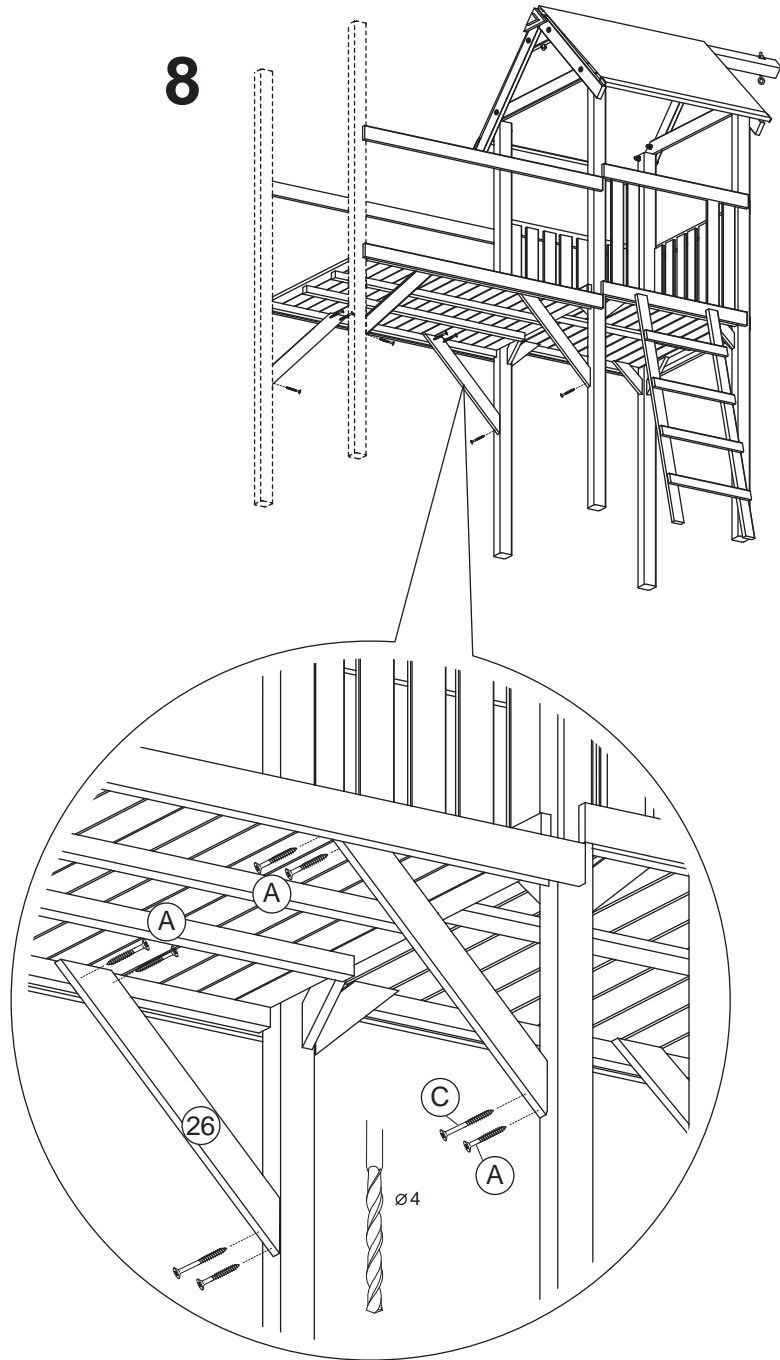







67512



5900236675124

- 1x**  (28)  
45 x 45 x 1000
- 2x**  (8)  
40 x 90 x 340
- 2x**  (2)  
30 x 90 x 1090
- 1x**  (29)  
22 x 90 x 1000
- 2x**  (27)  
90 x 90 x 2400

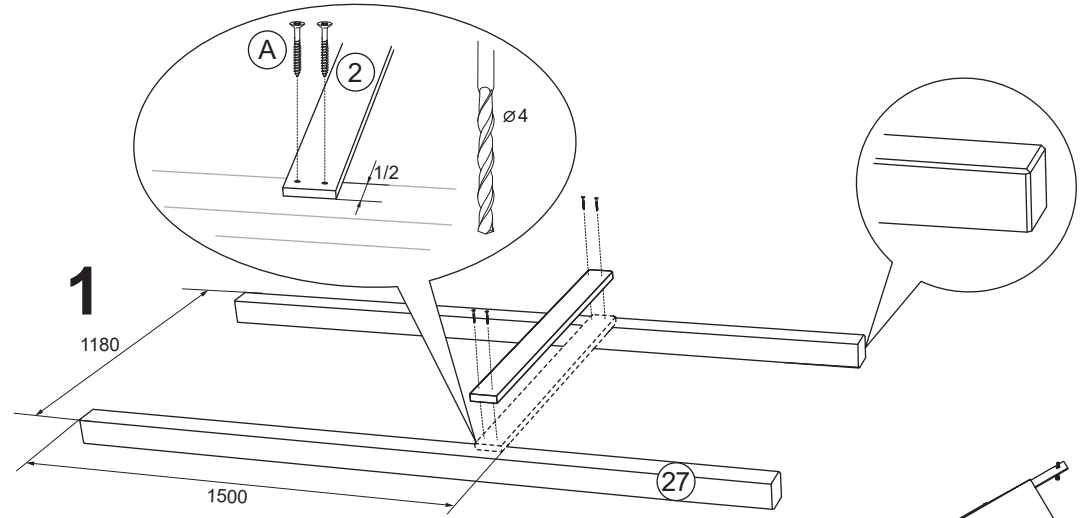

- 21x** (A) - 5 x 70
- 2x** (C) - 5 x 120
- 4x** (D) - 4 x 60

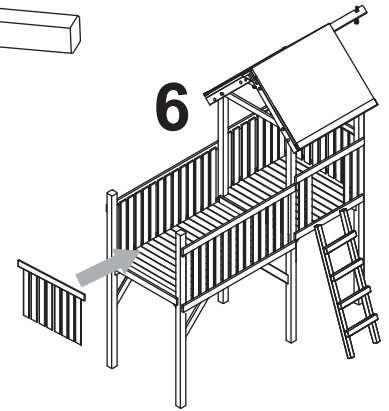
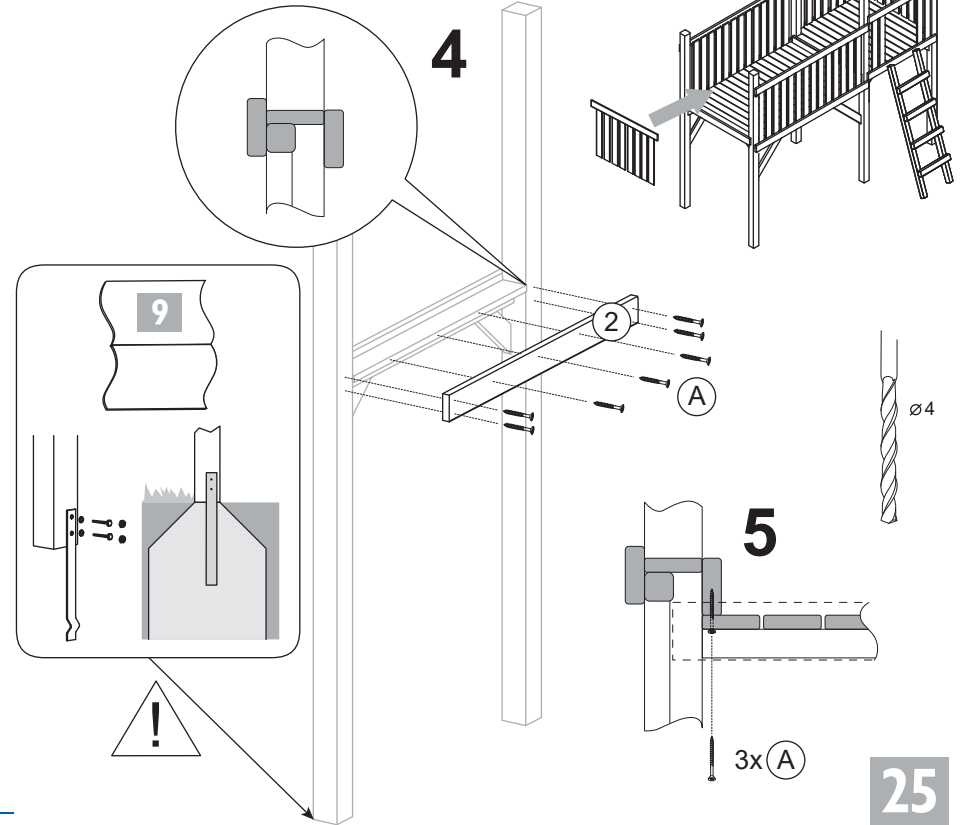
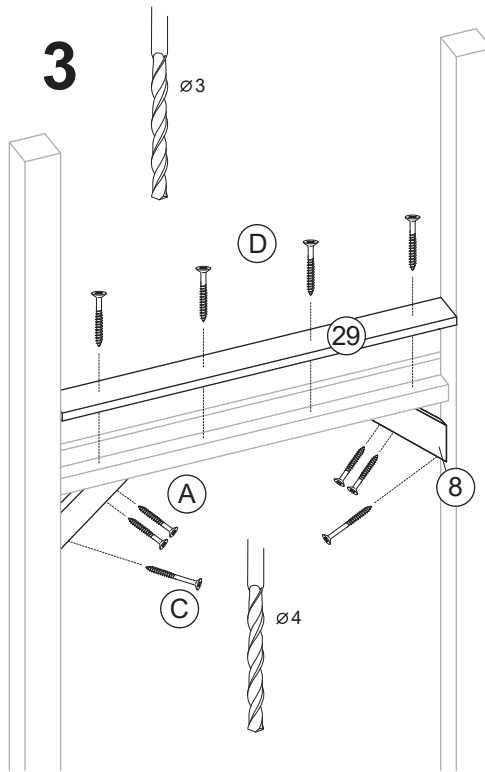
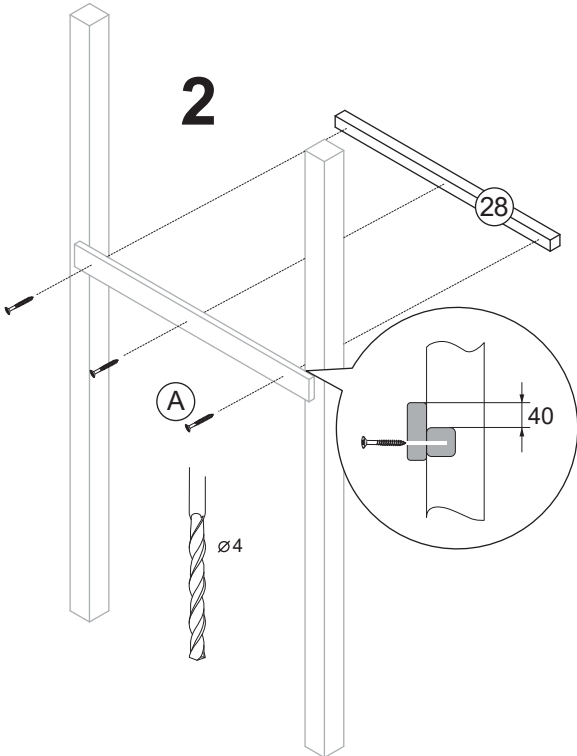

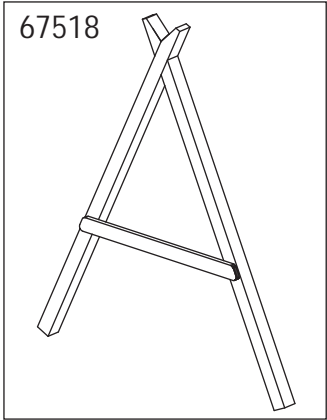

67518



6x **A** - 5 x 70

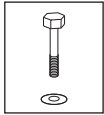

2x **L** - 10 x 140

5900236675186

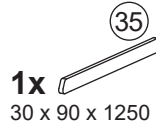

1x **35**  
30 x 90 x 1250

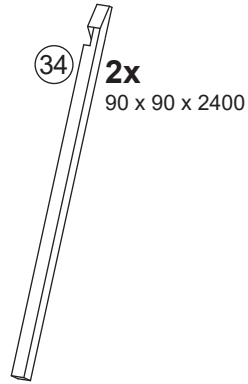

2x **34**  
90 x 90 x 2400

1x **39** 90 x 90 x 2400

6x **K** - 8 x 80

2x **U** - M12 x 140

1x **S** - 8 x 130

67521 = **39**  
5900236675216

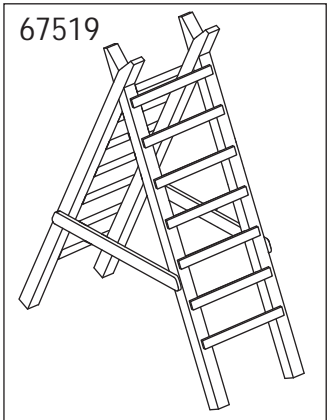
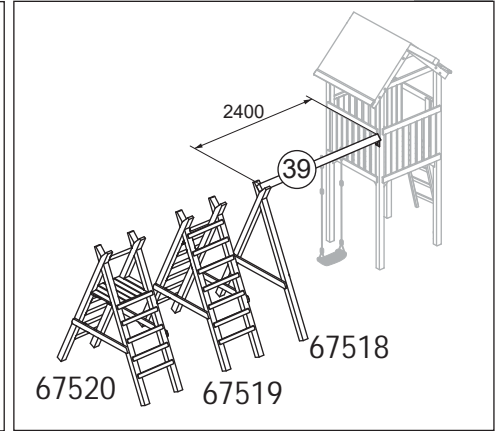

67519



68x **A** - 5 x 70

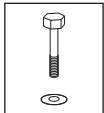

2x **L** - 10 x 140

5900236675193

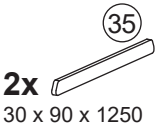

2x **35**  
30 x 90 x 1250

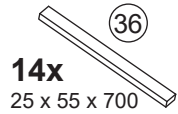

14x **36**  
25 x 55 x 700

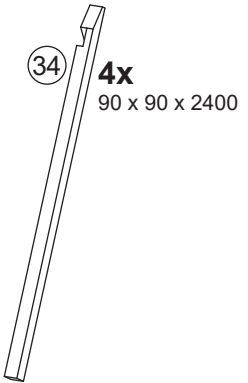

4x **34**  
90 x 90 x 2400

1x **40** 90 x 90 x 3000

6x **K** - 8 x 80

4x **U** - M12 x 140

1x **S** - 8 x 130

67522 = **40**  
5900236675223

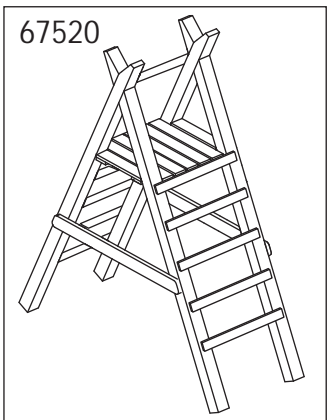
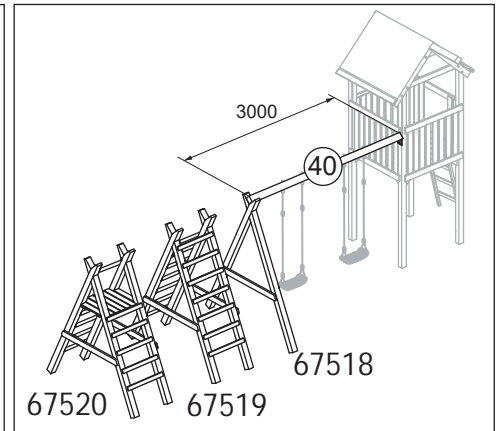

67520



56x **A** - 5 x 70

6x **E** - 4 x 50

28x **B** - 3,5 x 3,5

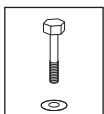

2x **L** - 10 x 140

5900236675209

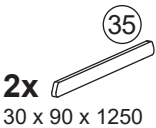

2x **35**  
30 x 90 x 1250

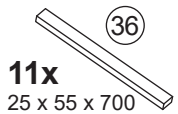

11x **36**  
25 x 55 x 700



2x **38**  
19 x 90 x 405

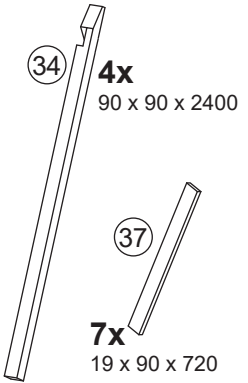

4x **34**  
90 x 90 x 2400



7x **37**  
19 x 90 x 720

1x **41** 90 x 90 x 3600

6x **K** - 8 x 80

5x **U** - M12 x 140

1x **S** - 8 x 130

67523 = **41**  
5900236675230

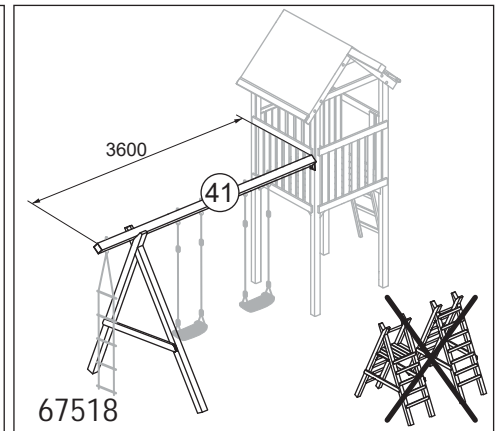

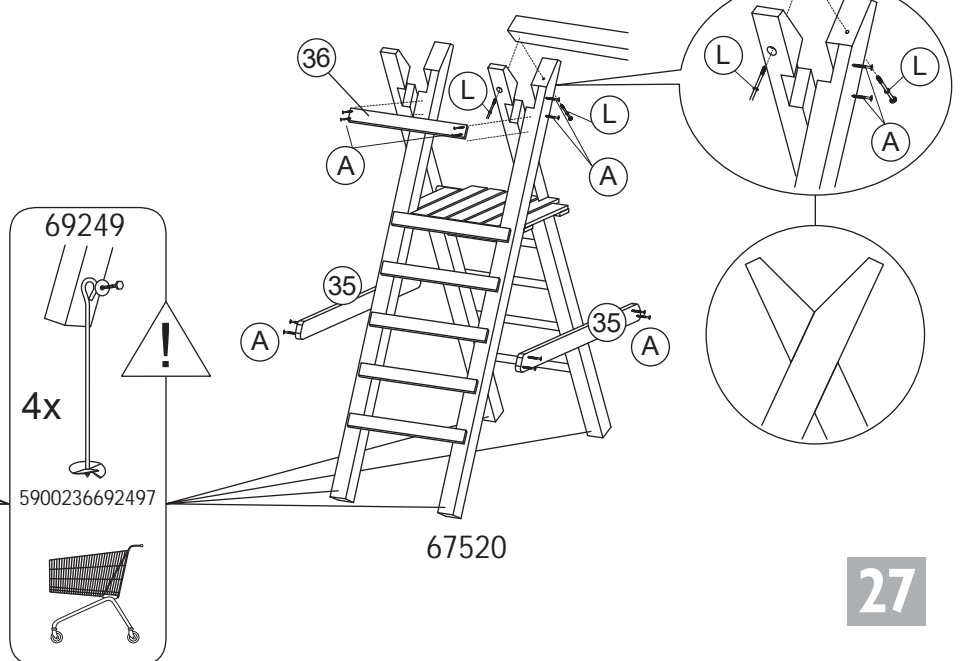
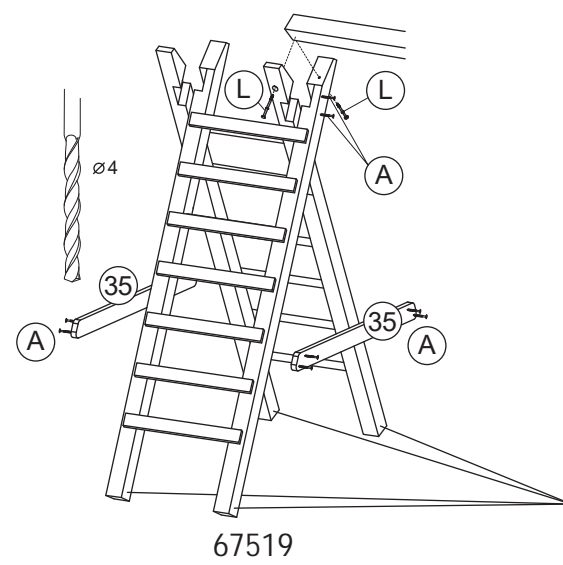
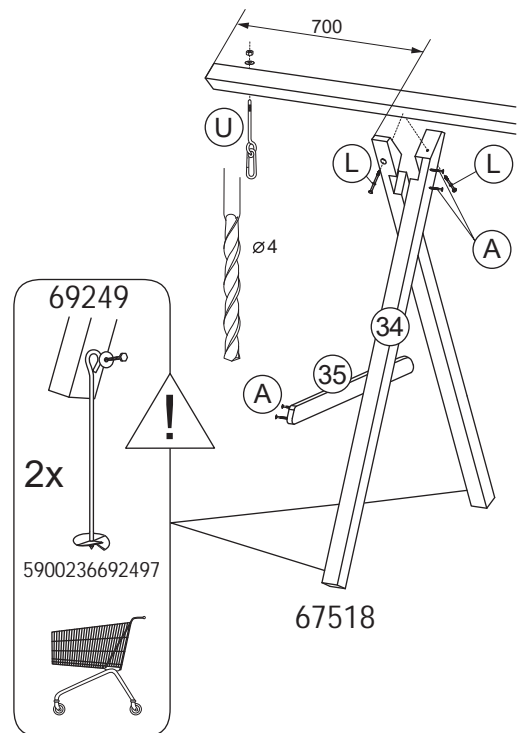
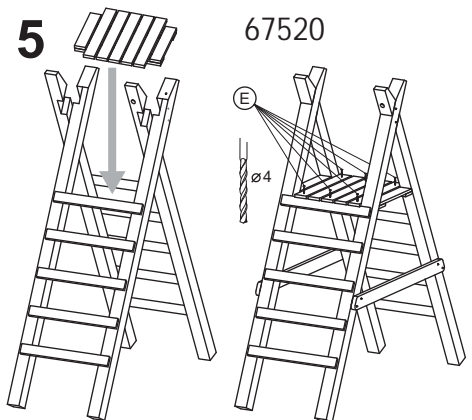
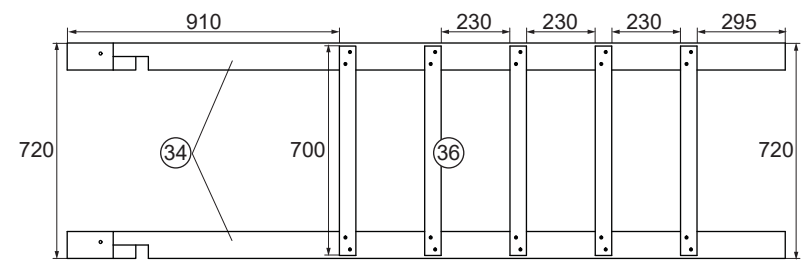
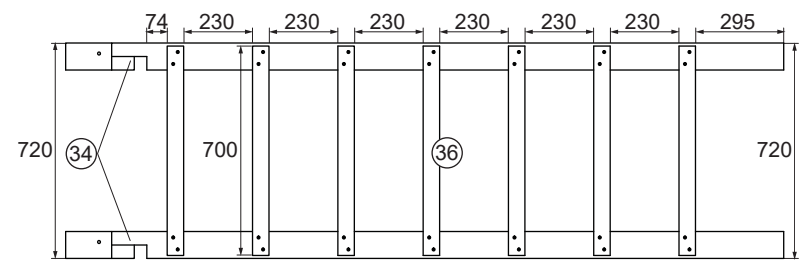
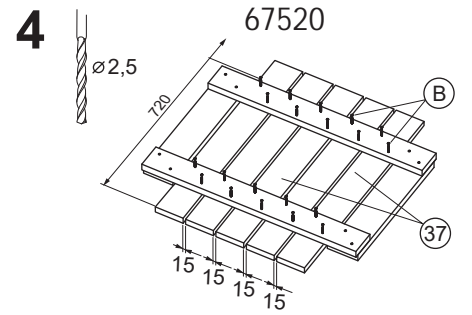
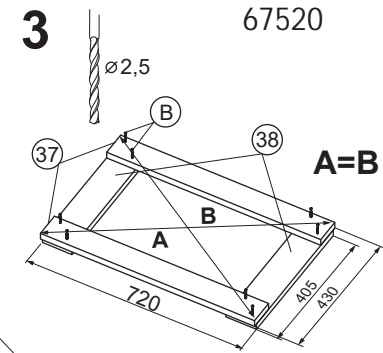
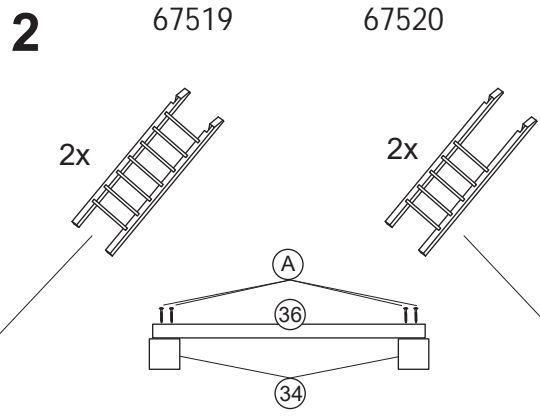
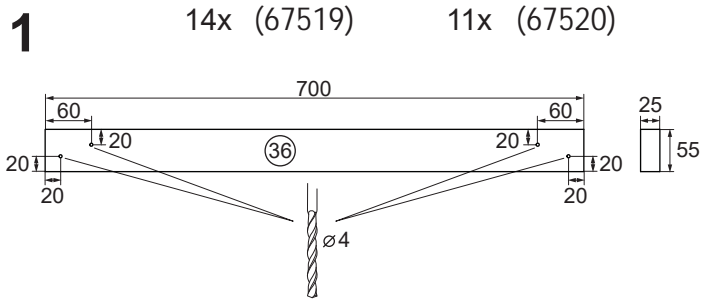

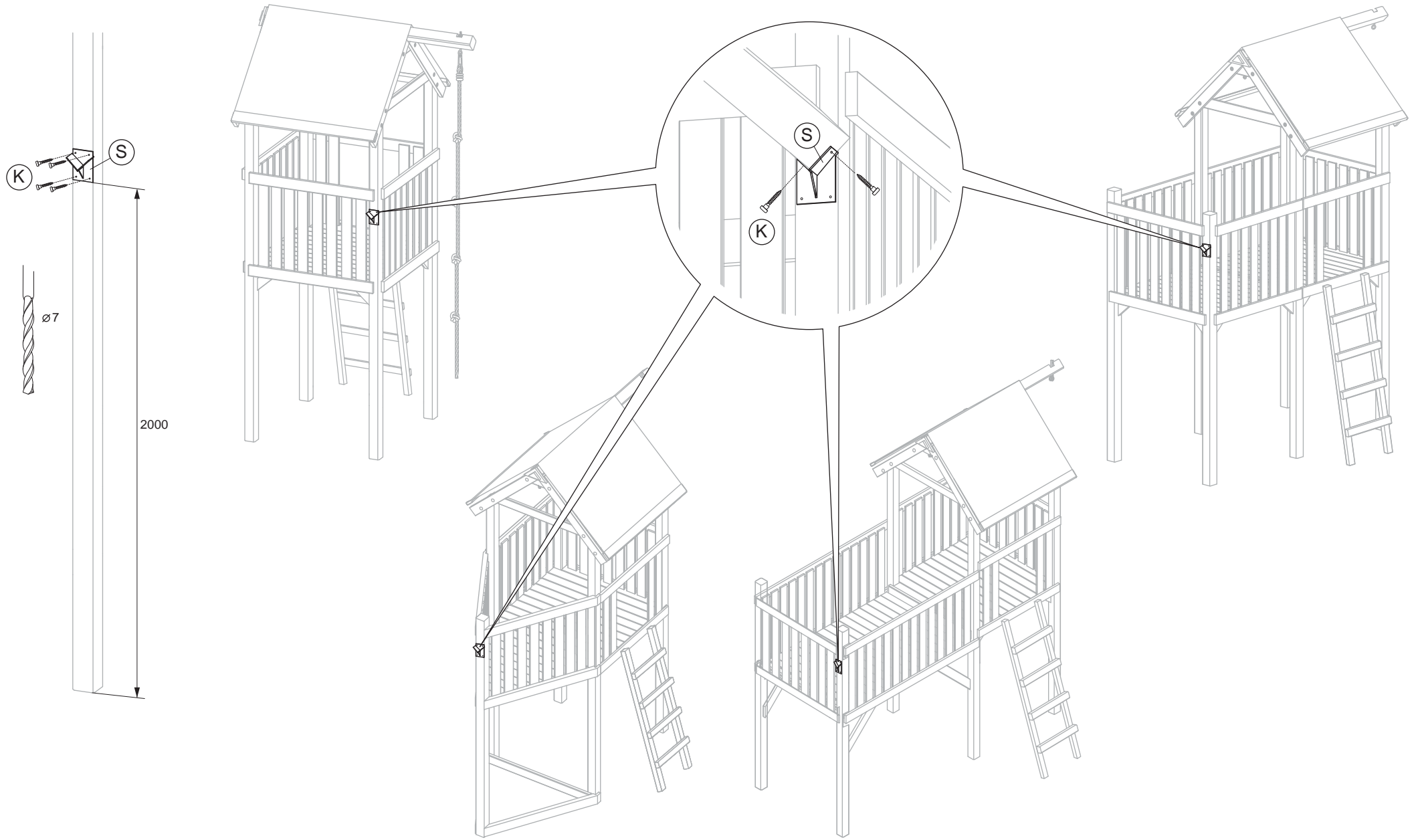

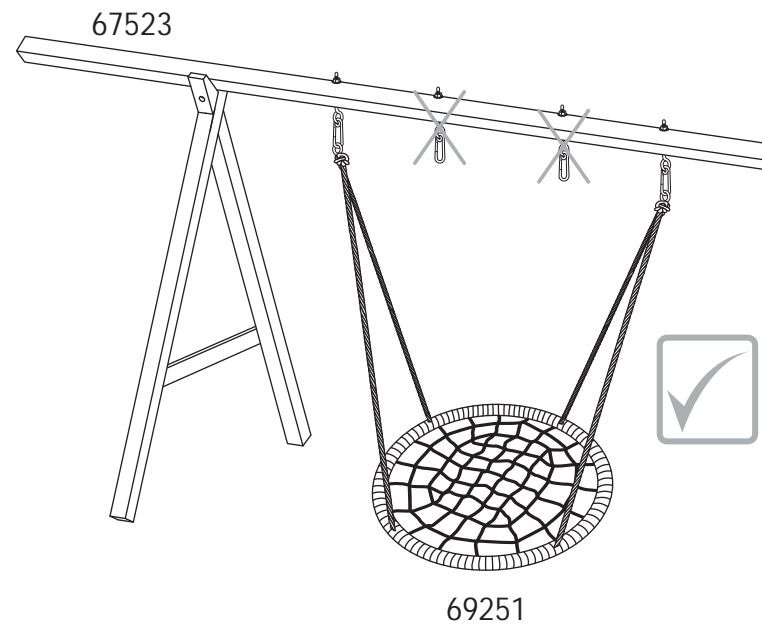
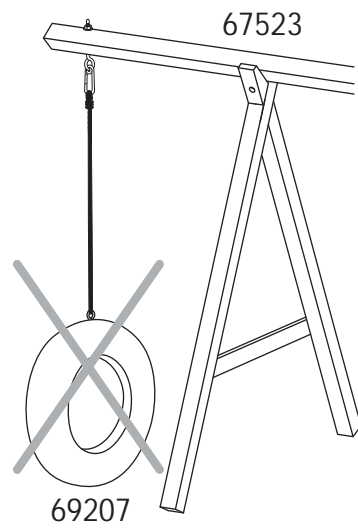
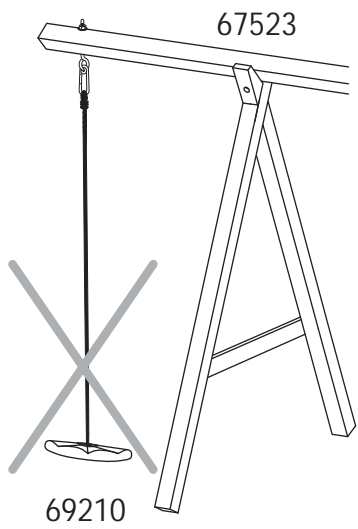
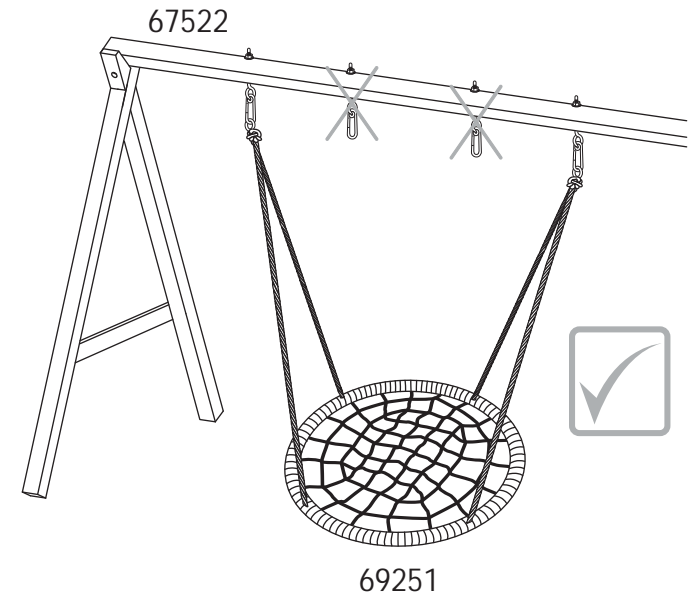
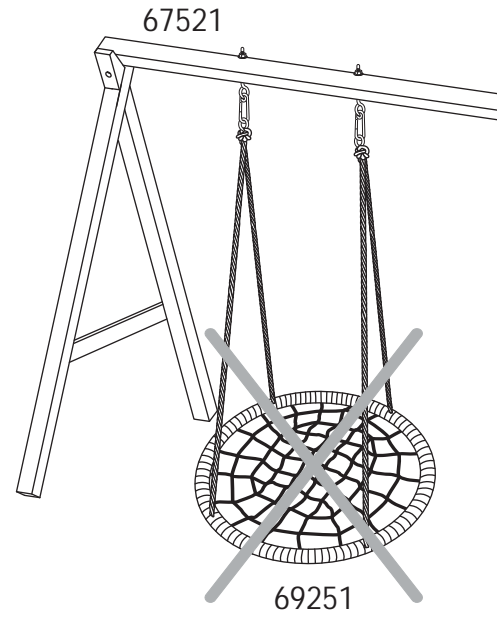
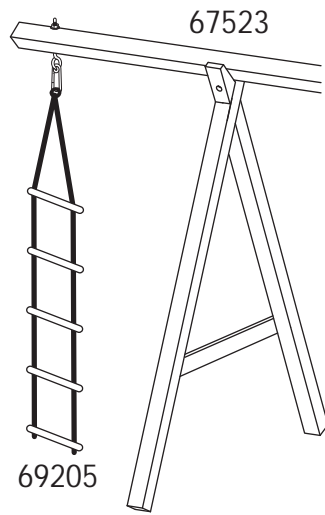
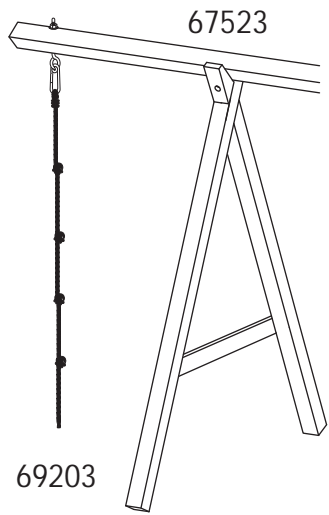

67510

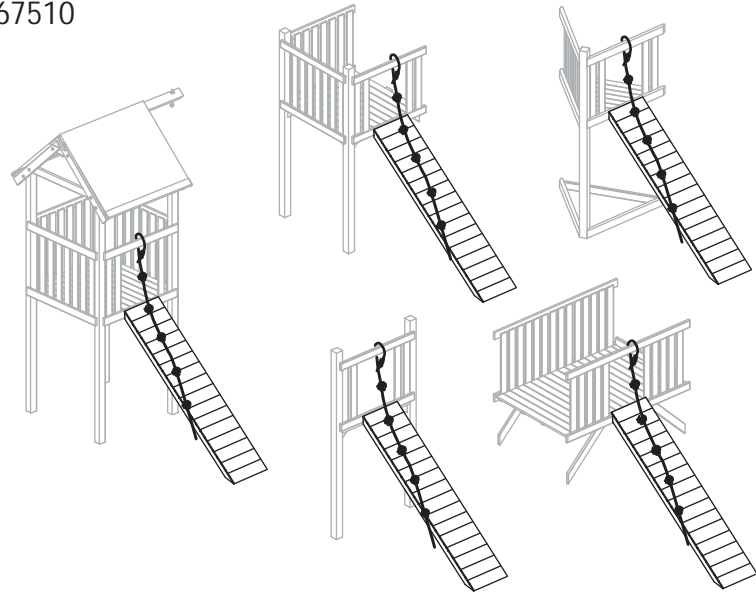

**DELTA**  
GARTENHOLZ

(M)



1x  
2900

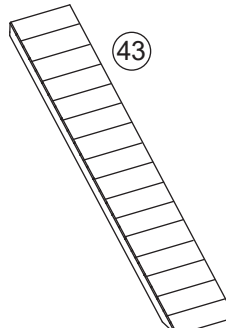

1x  
500 x 2320

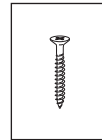

4x (C) - 5 x 120

5900236675100

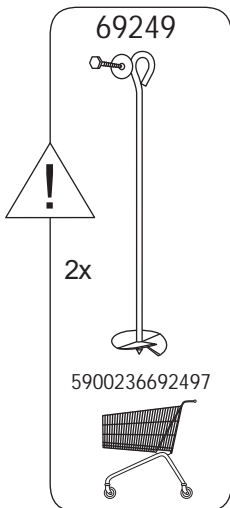
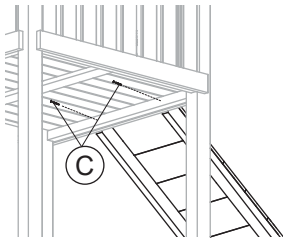

69249

2x

5900236692497

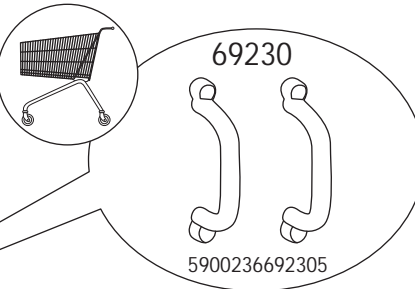
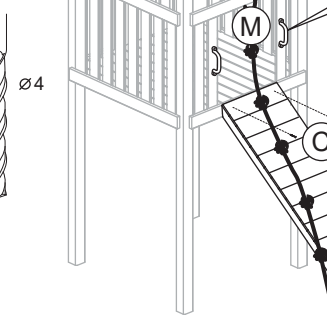

69230

5900236692305

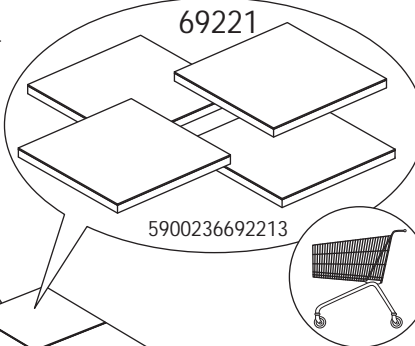

69221

5900236692213

67524

30

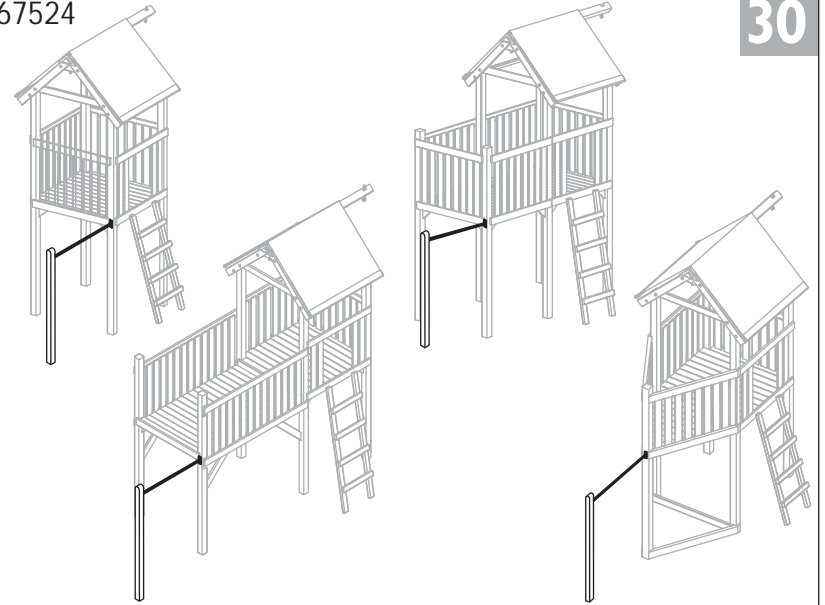

5900236675247

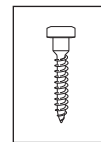

4x (K) - 8 x 80

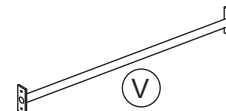
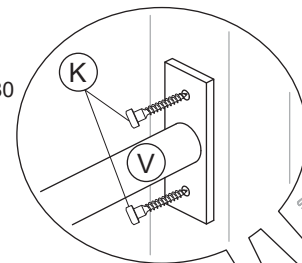

1x  
45 x 125 x 1250

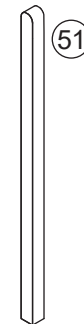

1x  
90 x 90 x 2100

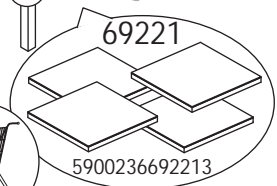
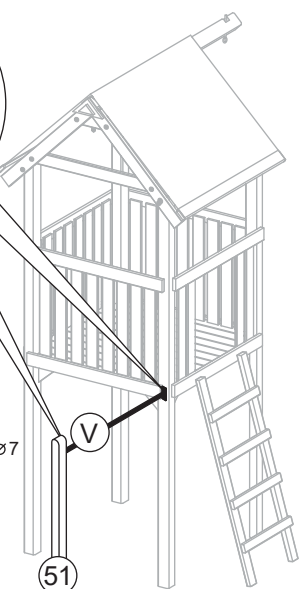
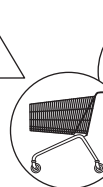
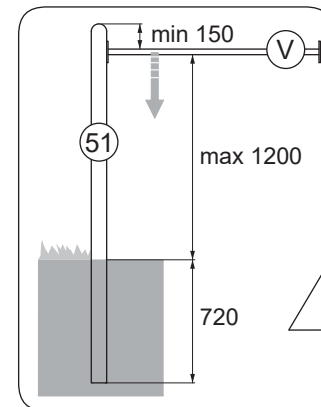

69221

5900236692213

69250

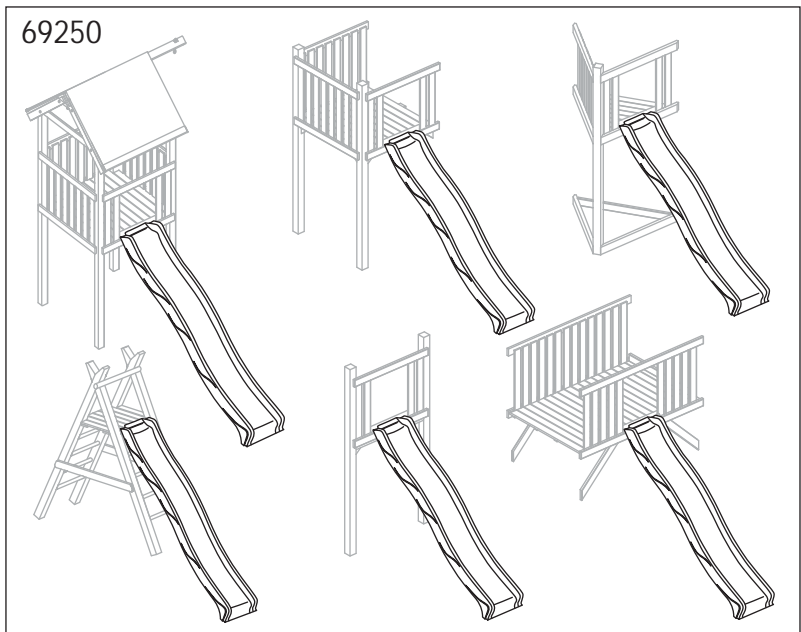

5900236692503

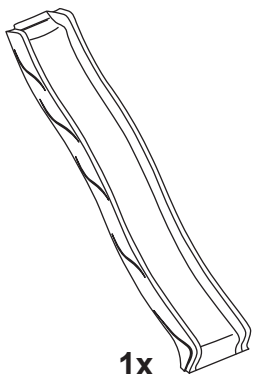

1x  
2900

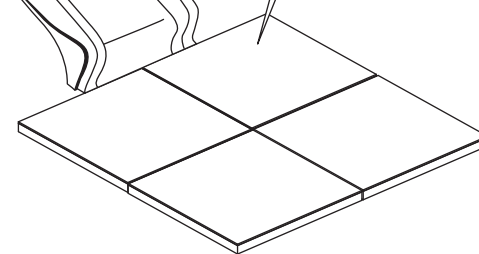
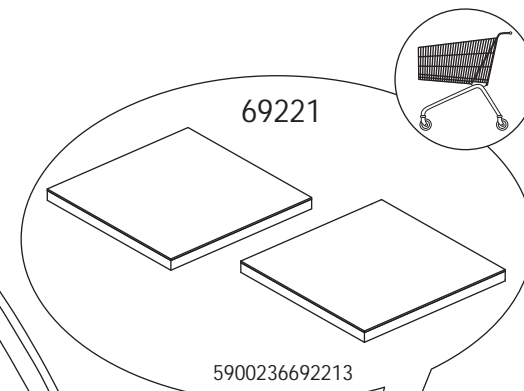
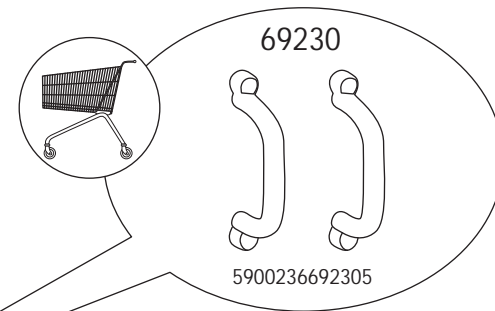
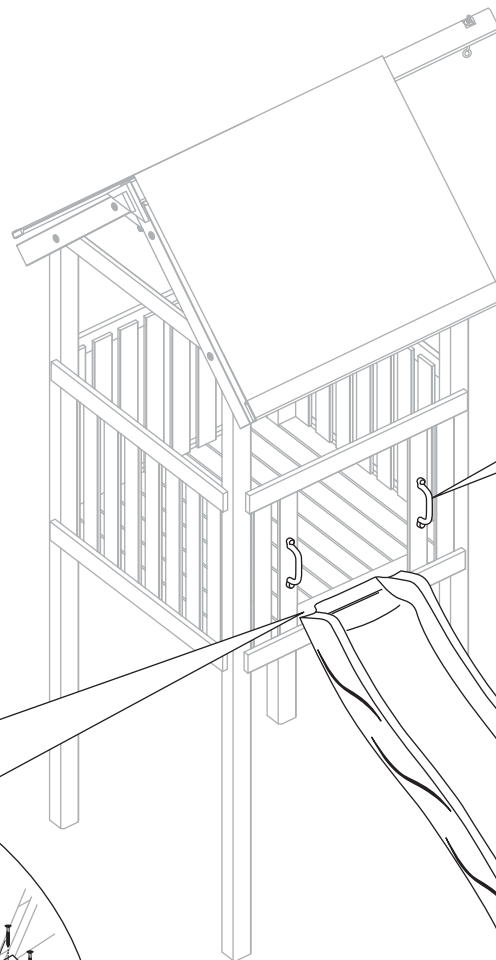
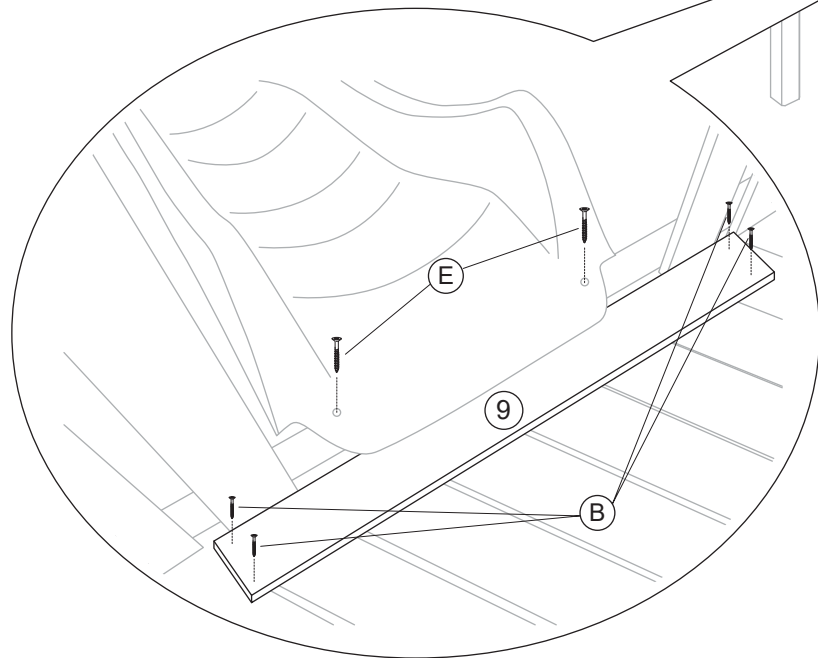



**[www.multi-play.net](http://www.multi-play.net)**

Delta Gartenholz Polska Sp. z o.o.  
Zdroje 93  
PL - 89-505 Małe Gacno  
Poland  
Tel.: +48 52 - 33618-00  
Fax: +48 52 - 33618-13

[info@delta-gartenholz.com](mailto:info@delta-gartenholz.com)  
[www.delta-gartenholz.com](http://www.delta-gartenholz.com)

Delta Gartenholz GmbH & Co. KG  
Werner-Bock-Str. 36  
D-33602 Bielefeld  
Germany  
Tel.: +49 (0)521 - 988188-0  
Fax: +49 (0)521 - 988188-13