

Metall-Mülltonnenbox

Bedienungs- und Montageanleitung

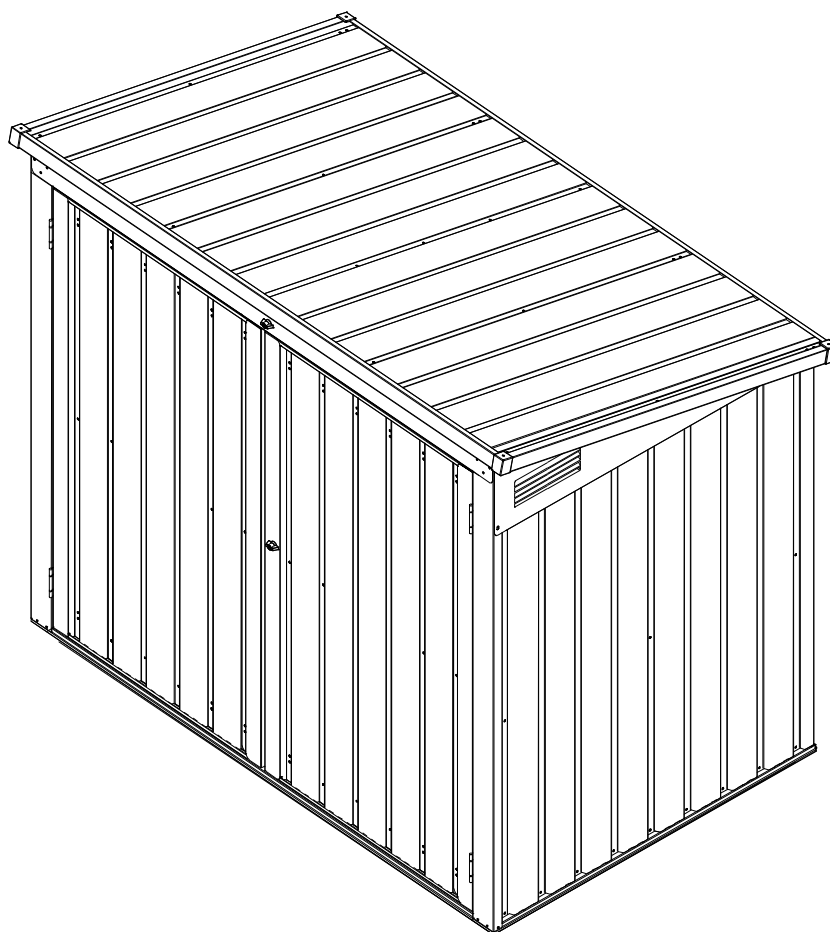

BS-T2D

**LESEN SIE DIE ANLEITUNG SORGFÄLTIG DURCH UND BEWAHREN SIE
DIESE FÜR DIE ZUKÜNFTIGE VERWENDUNG AUF.**

Liebe Kundin, lieber Kunde!

Herzlichen Glückwunsch zum Kauf dieses Qualitätsproduktes. Dieses Produkt entspricht europäischen und nationalen Anforderungen. Um diese Anforderungen zu erhalten und die Konformität zu gewährleisten, bitten wir Sie, sich an diese Anleitung zu halten. Sie beinhaltet wichtige Informationen bzgl. der Bedienung und Benutzung dieses Produktes. Bitte bewahren Sie diese Anleitung zur späteren Verwendung auf.



Schäden, die durch unsachgemäße Bedienung entstehen, unterliegen nicht dem Garantieanspruch. Auch für daraus resultierende Folgeschäden wird keine Haftung übernommen. Für Sach- oder Personenschäden durch nicht ordnungsgemäße Bedienung, unter Nichtberücksichtigung der Sicherheitshinweise, wird keine Haftung übernommen. Es erlischt der Garantieanspruch.

Technische Daten:

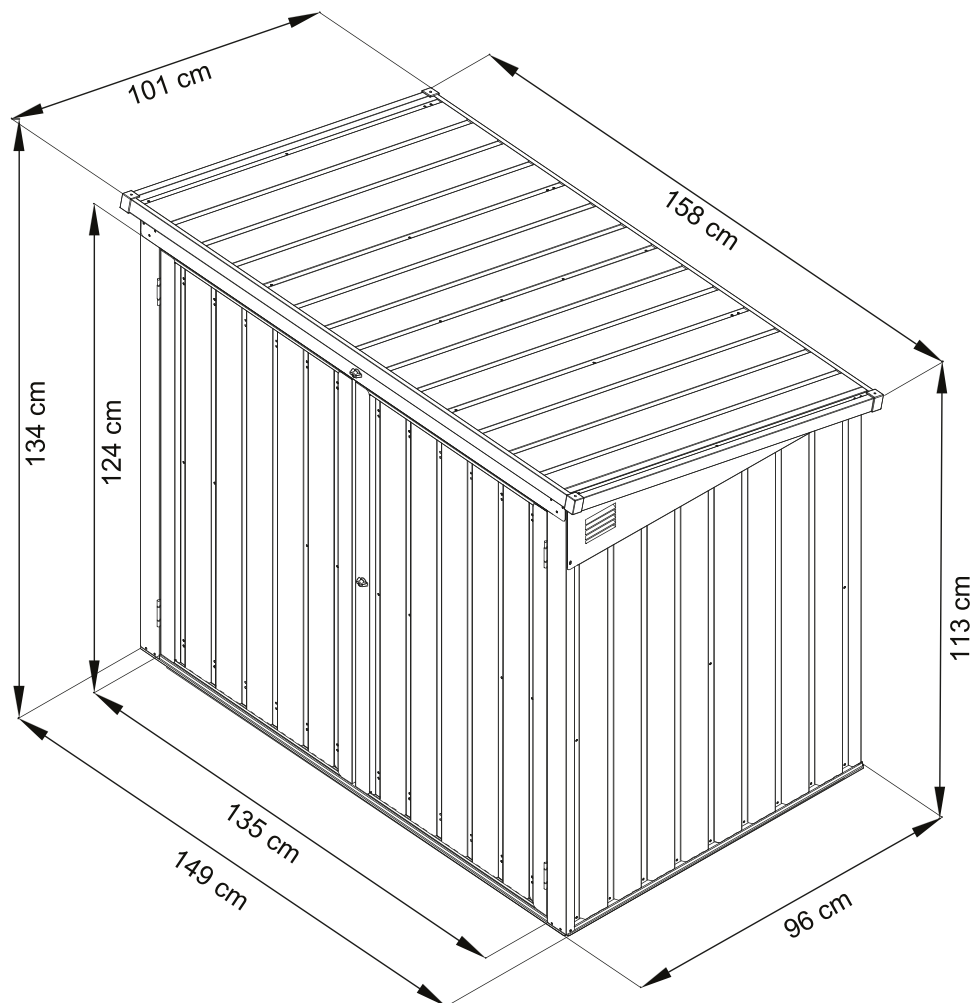

BxHxT ca. 158x134x101 cm

Innenmaße BxHxT ca. 149x113x96 cm

Lagerfläche ca. 1,5 m²

Tür BxH ca. 135x124 cm

Dachlast max. 60 kg/m² (588 N/m²)

Anzahl der für den Aufbau benötigten Personen: 2

Montagezeit für das Haus: ca. 1-2 Stunden

Vor der Montage

1. Erkundigen Sie sich bei der örtlichen Behörde, ob eine Baugenehmigung erforderlich ist.
2. Befolgen Sie die örtlichen Bauvorschriften für Arbeitsräume, Fundamente, Standorte usw.
3. Wählen Sie einen windgeschützten Ort und einen windstillen Tag für die Montage.
4. Bestimmen Sie die geeigneten Gebäudefundamente und Ankersysteme.
5. Überprüfen Sie die Vollständigkeit und den Zustand der Teile gemäß Stückliste.
6. Befolgen Sie die in der Anleitung angegebenen Montageschritte.
7. Richten Sie den Boden des Gartenhauses aus, indem Sie ihn rundum mit einer Wasserwaage prüfen.
8. Legen Sie keine Gegenstände auf die Metallplatten, um Verformungen zu vermeiden.
9. Entnehmen Sie alle Teile vorsichtig den Kartons, da scharfkantige Teile andernfalls die Beschichtung der Metallplatten beschädigen könnten.
10. Entfernen Sie die Kunststoffolie der Metallplatte erst nach der Montage.

Sicherheitstechnische Hinweise

1. Tragen Sie während der Montage des Gartenhauses Oberbekleidung mit langen Ärmeln, lange Hosen sowie eine Schutzausrüstung, z. B. Arbeitshandschuhe und Augenschutz.
2. Verwenden Sie für die Montage des Gartenhauses ausschließlich das in dieser Anleitung empfohlene Werkzeug.
3. Halten Sie Kinder und Haustiere von der Montagestelle fern.
4. Befolgen Sie bei der Montage des Gartenhauses die unten nachfolgend beschriebenen Anweisungen.
5. Montieren Sie das Gartenhaus nicht bei starkem Wind oder anderen extremen Witterungsverhältnissen.
6. Verwenden Sie keine Elektrowerkzeuge in nasser oder feuchter Umgebung. Es droht die Gefahr von Stromschlägen.
7. Stützen Sie sich während der Montage nicht auf Teilen des Gartenhauses ab.
8. Stellen Sie das Gartenhaus nicht direkt auf unbefestigtem/unebenem Untergrund auf.
9. Wählen Sie einen geeigneten, festen Untergrund aus. Der Hersteller haftet nicht für die Auswahl des Untergrundes.
10. Verankern Sie Ihr Gartenhaus fest mit dem Fundament, um es vor starkem Wind zu schützen.



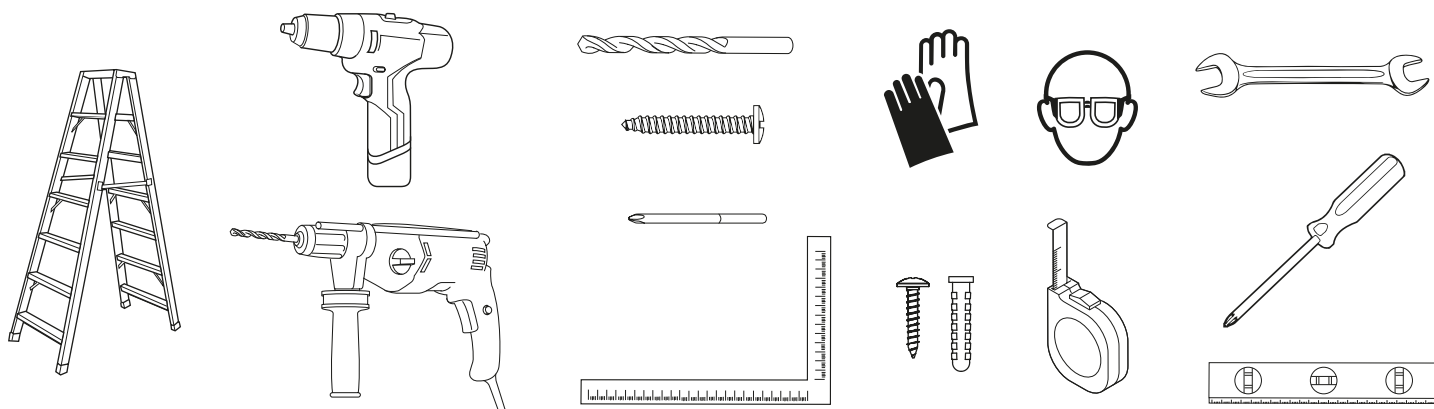







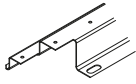
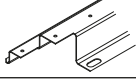
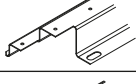
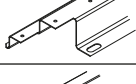



Diese Werkzeuge benötigen Sie:











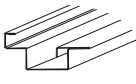
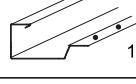
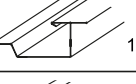

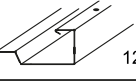

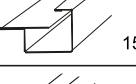
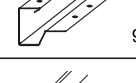
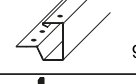



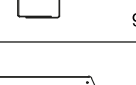
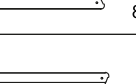



Hinweis: Verwenden Sie immer Arbeitshandschuhe, wenn Sie mit Stahlblechen arbeiten.













Teile- und Musterliste:

Alle Teile sind nummeriert. Sollten Teile fehlen oder beschädigt sein, kennzeichnen Sie bitte die Nummer des Teils, das ausgetauscht oder ersetzt werden soll.

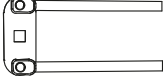
Teil	Abbildung	Anzahl
1	 1479 mm	1
2	 944 mm	1
2-1	 944 mm	1
3	 1479 mm	1
4L	 1290 mm	1
4R	 1290 mm	1
13	 1080 mm	2
14	 1090 mm	1
15	 1	1
16	 1	1
17	 890 mm	1
18	 890 mm	1
19	 1469 mm	1
20	 1476 mm	1
P1	 1080 mm	4
P2	 1080 mm	1
P3	 1080 mm	1

Teil	Abbildung	Anzahl
40	 664 mm	4
41	 1203 mm	1
42	 1203 mm	1
43	 1203 mm	1
44	 1203 mm	1
48	 1568 mm	1
49	 1568 mm	1
50	 998 mm	1
51	 998 mm	1
D1	 1202 mm	2
D2	 1202 mm	2
D3	 997 mm	1
D4	 997 mm	2
52	 948 mm	1
53	 857 mm	1
54	 857 mm	1
K1	 2	2

Teil	Abbildung	Anzahl
29		4
29-1		4
65		1
32		1
J1		4
BL		1
BR		1
55	 744 mm	2
56	 744 mm	2

Teil	Abbildung	Anzahl
K2	 500 mm	2
G4		4
W1		4
G3	 220X70-600N	1
GC		4
B1		1
B4		1
B2		1
G6		2
F1		317
F2		30
F3		16
S2		363
S3		179

Pflege- und Wartungsanleitung

1. Entfernen Sie regelmäßig Blätter und Schnee vom Dach des Gartenhauses. Nutzen Sie hierfür zum Beispiel einen Besen mit weichen Borsten. Achtung: Größere Mengen Schnee auf dem Dach können das Gartenhaus beschädigen.
2. Betreten Sie nicht das Dach des Gartenhauses.
3. Lehnen Sie keine schweren Gegenstände an die Wandplatten des Gartenhauses.
4. Überprüfen Sie regelmäßig den festen Sitz von Schrauben, Bolzen, Muttern usw.
5. Bei Temperaturwechseln kann Feuchtigkeit entstehen, die sich als Kondenswasser an den Wänden des Gartenhauses absetzt. Sorgen Sie deshalb stets für eine gute Belüftung des Gartenhauses.
6. Lagern Sie keine Chemikalien in dem Gartenhaus.

Schematische Darstellung der Einzelteil-Anordnung.

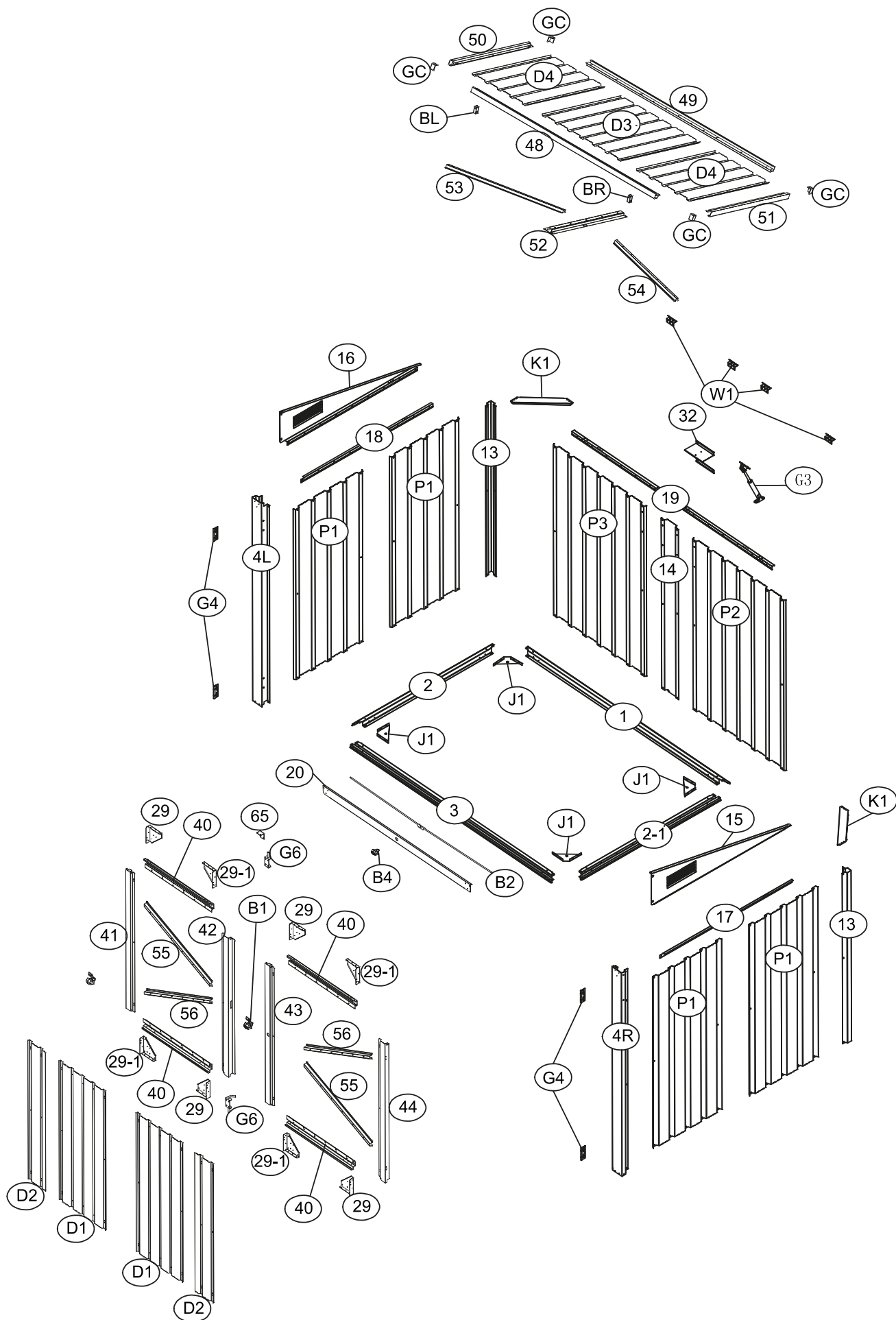



Entfernen Sie die Kunststoffolie (falls vorhanden) vor der Montage der überlappenden Elemente.



Um Kratzer / Beschädigungen auf der Oberfläche zu vermeiden, entfernen Sie die Kunststoffolie nicht vollständig von der Oberfläche.

Das Gartenhaus wird in vier Etappen aufgebaut (A-D). Bitte beachten Sie die neben den Etappen angegebene Seitennummerierung.

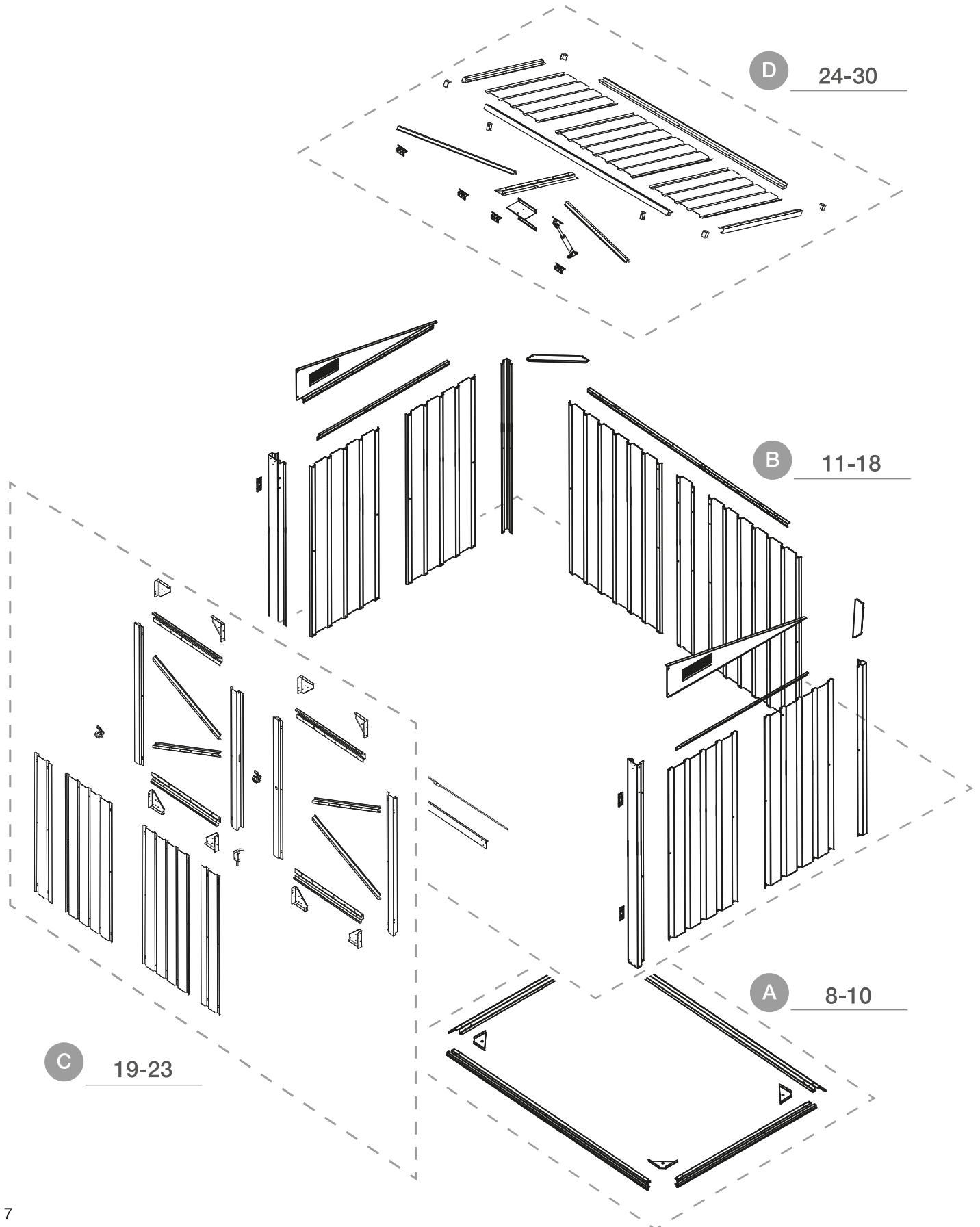

Montage des Grundrahmens

Achtung: Verletzungsgefahr durch scharfe Kanten.

Hinweis: Verwenden Sie immer Unterlegscheiben, wenn Sie Schrauben auf lackierten Oberflächen befestigen.

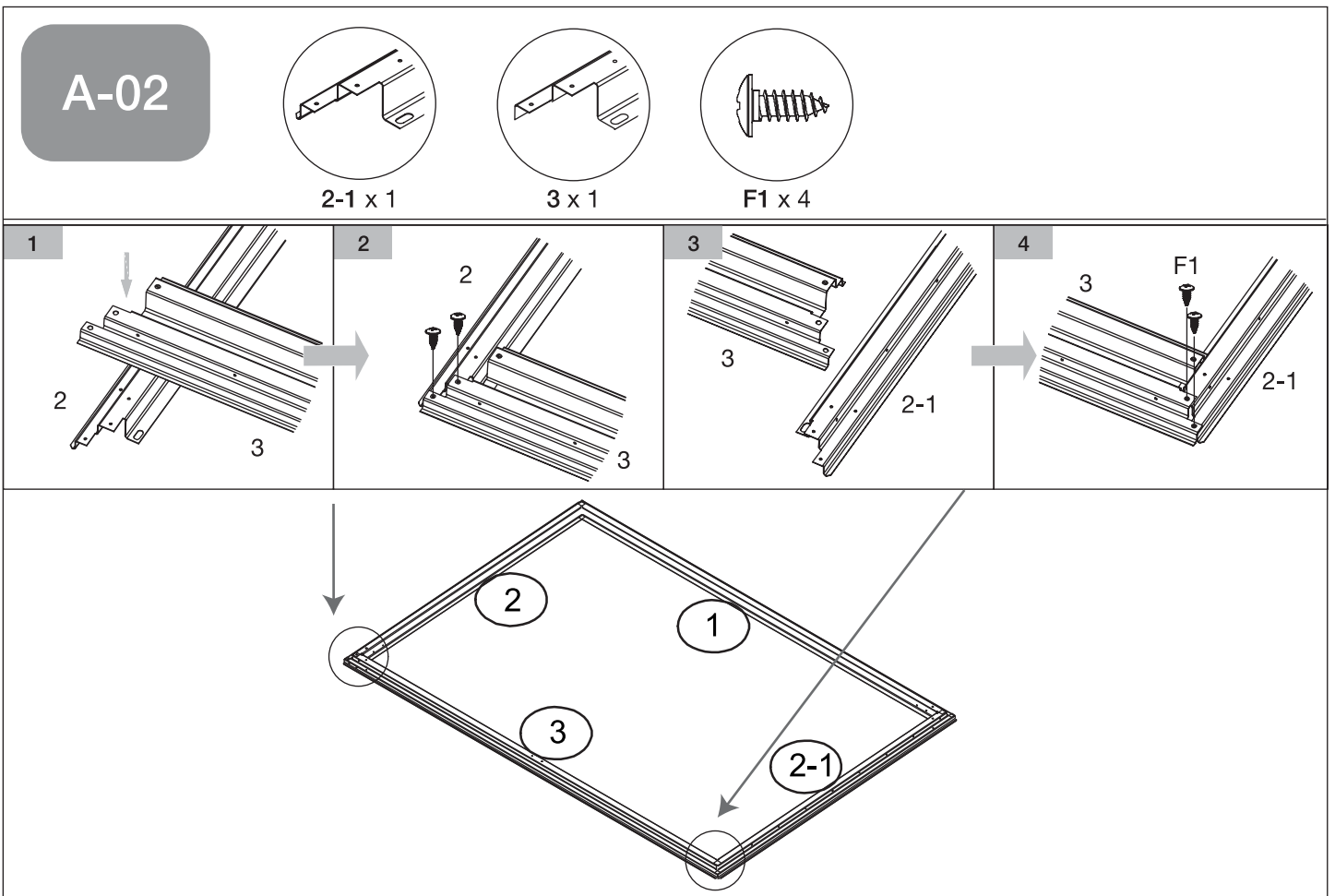
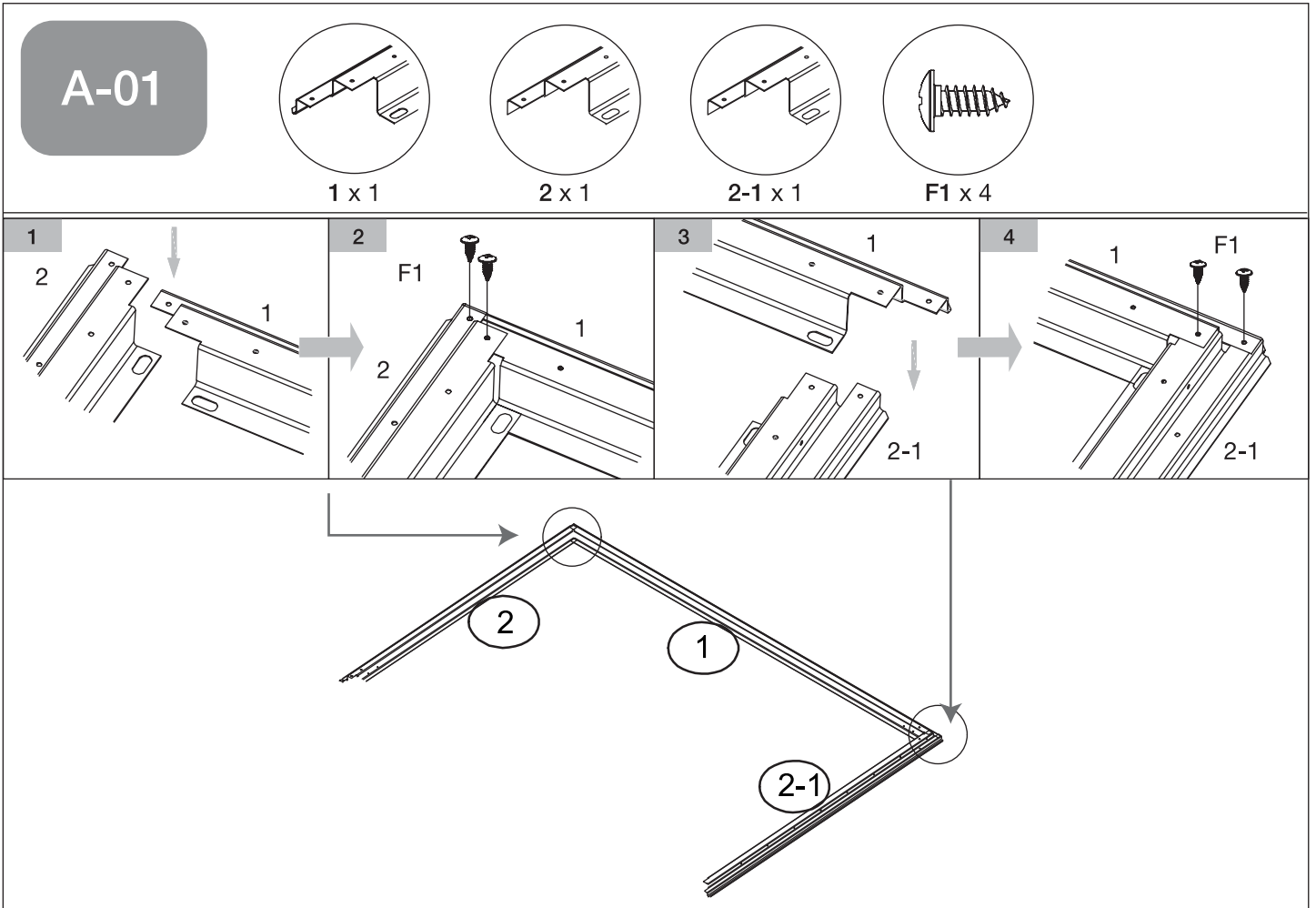

A-03

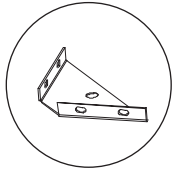

J1 x 4

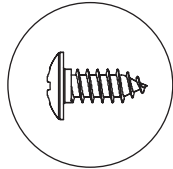

F1 x 16

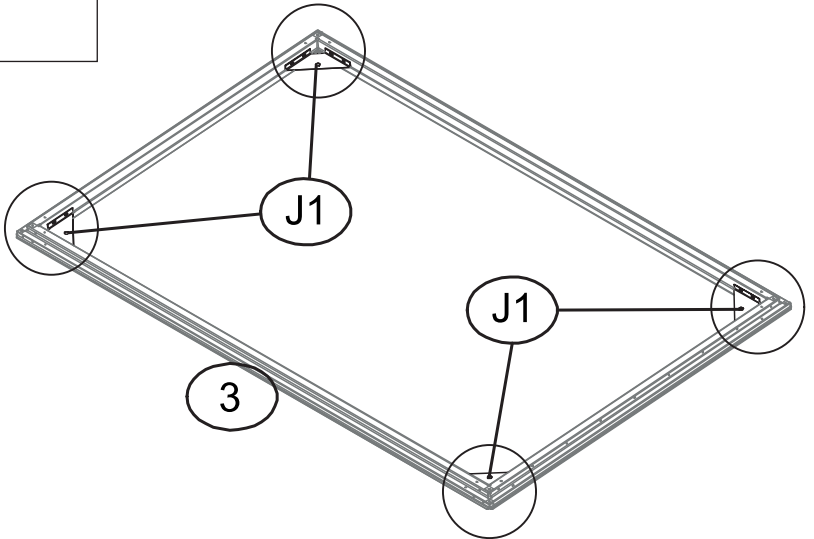
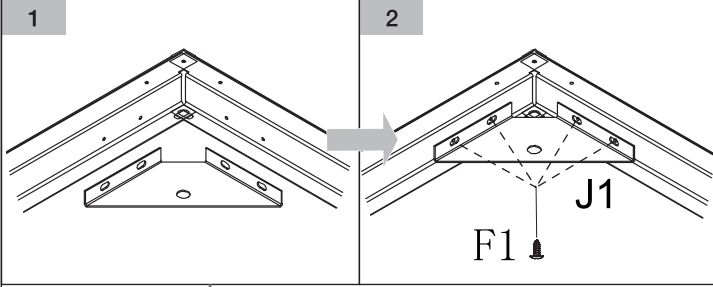

A-04



Exklusiv

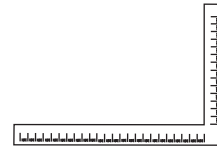
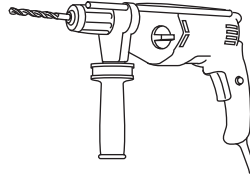

1

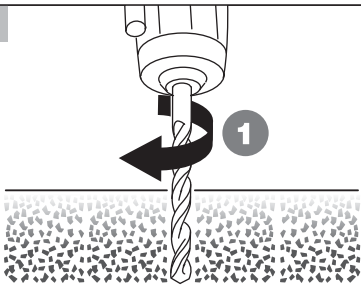

2

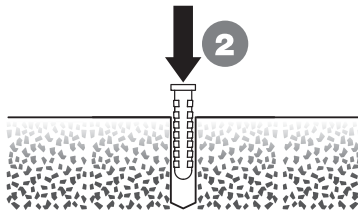

3

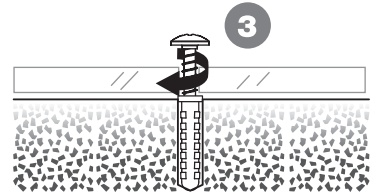

Achtung!
Bitte beachten Sie die Sicherheitshinweise Ihrer elektrischen Werkzeuge vor Benutzung.

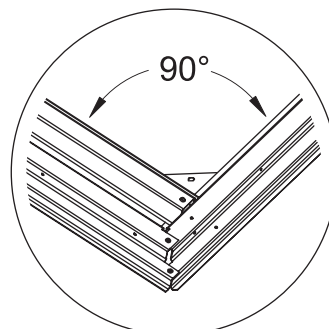
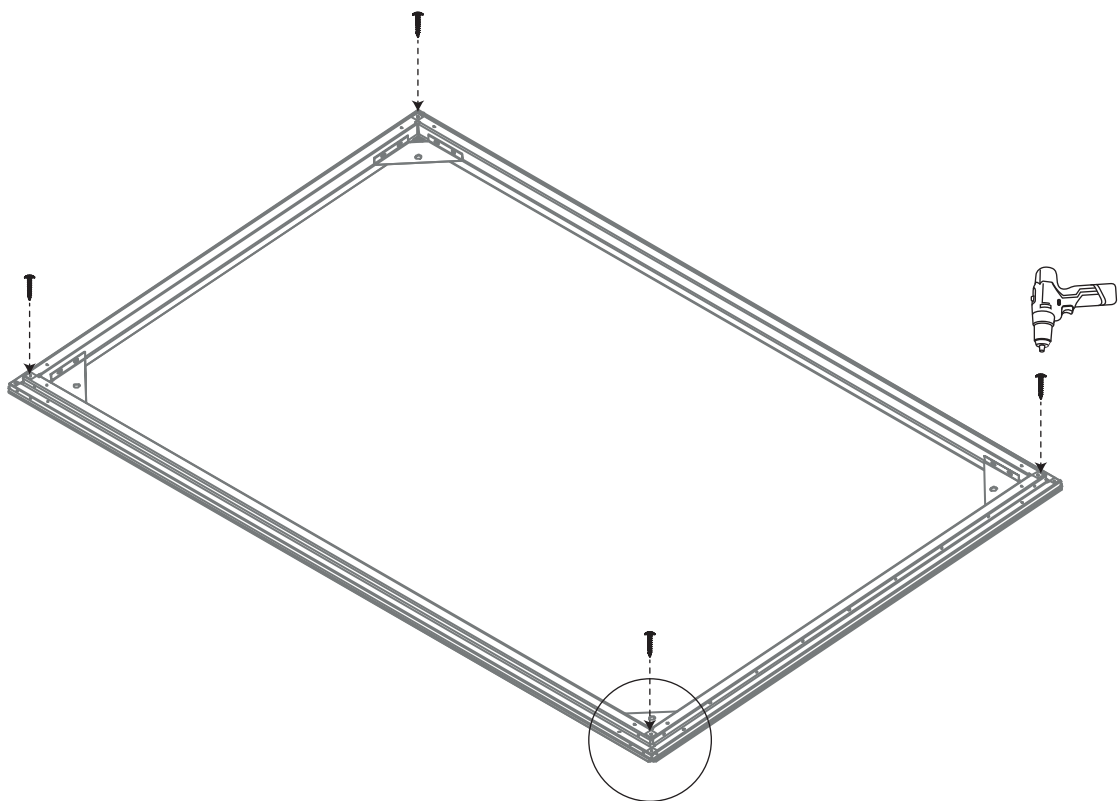

Messen Sie den Rahmen nach der Montage rundherum sorgfältig aus, um eine gleichmäßige Ausrichtung sicherzustellen.

Montage von Wand, Stützen & Dach

Achtung: Verletzungsgefahr durch scharfe Kanten.

B-01

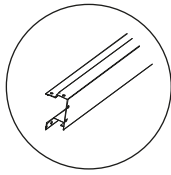

4L x 1

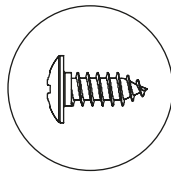

F1 x 4

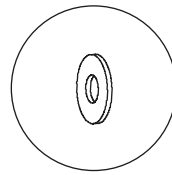

S3 x 3

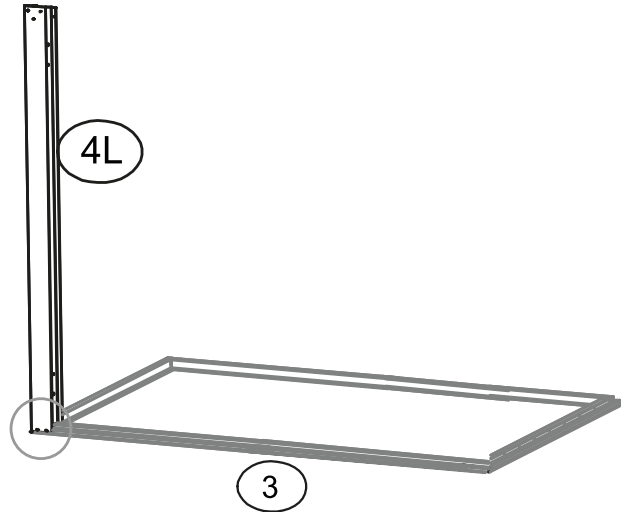
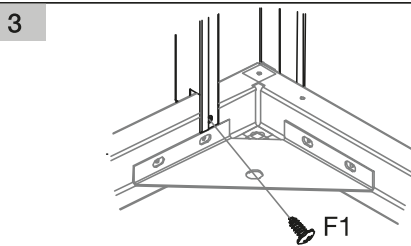
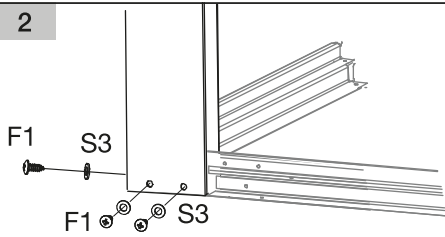
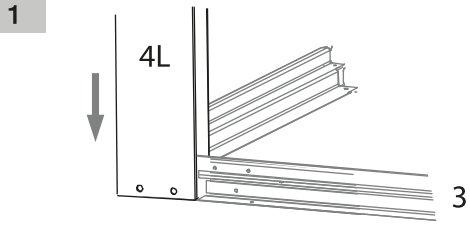

B-02

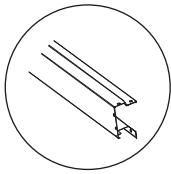

4R x 1

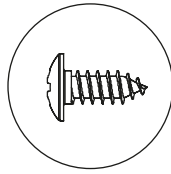

F1 x 4

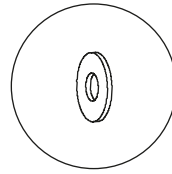

S3 x 3

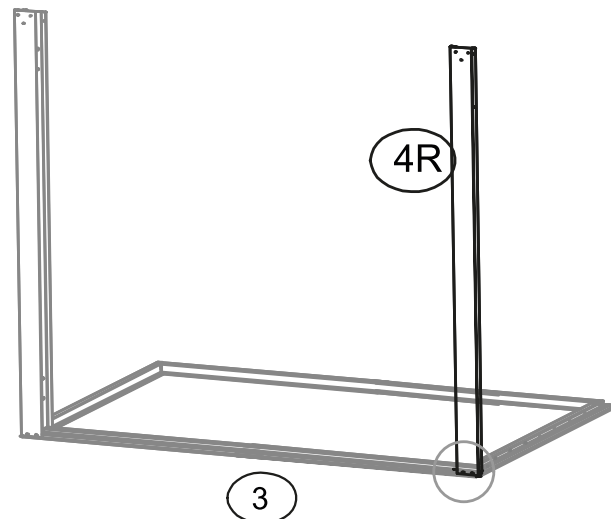
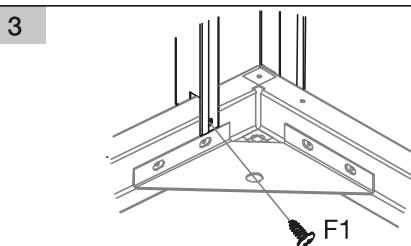
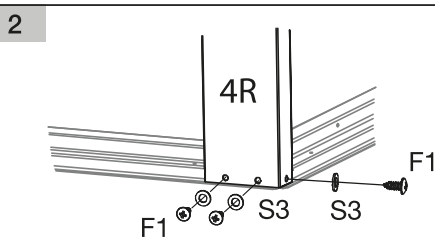
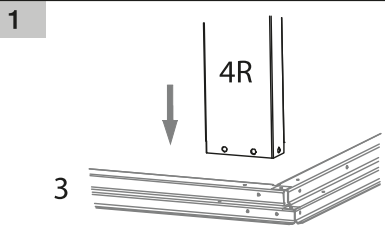

B-03

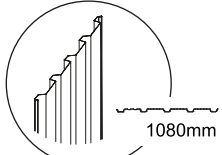

P1 x 2

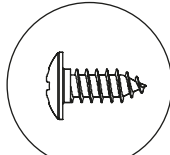

F1 x 8

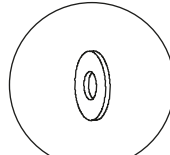

S3 x 10

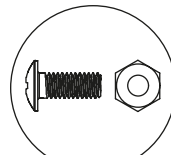

F2 x 2

1

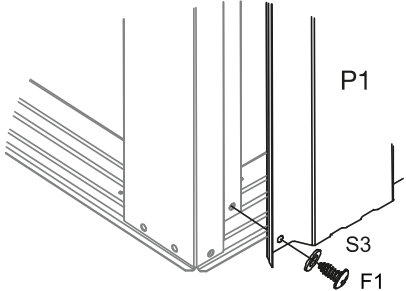

2

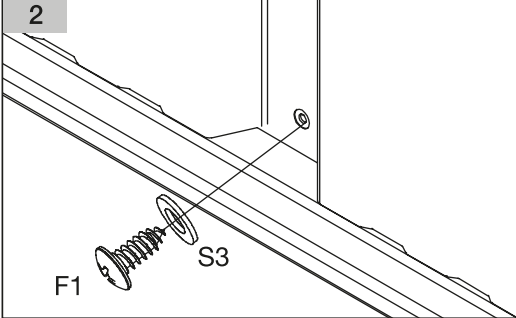

3

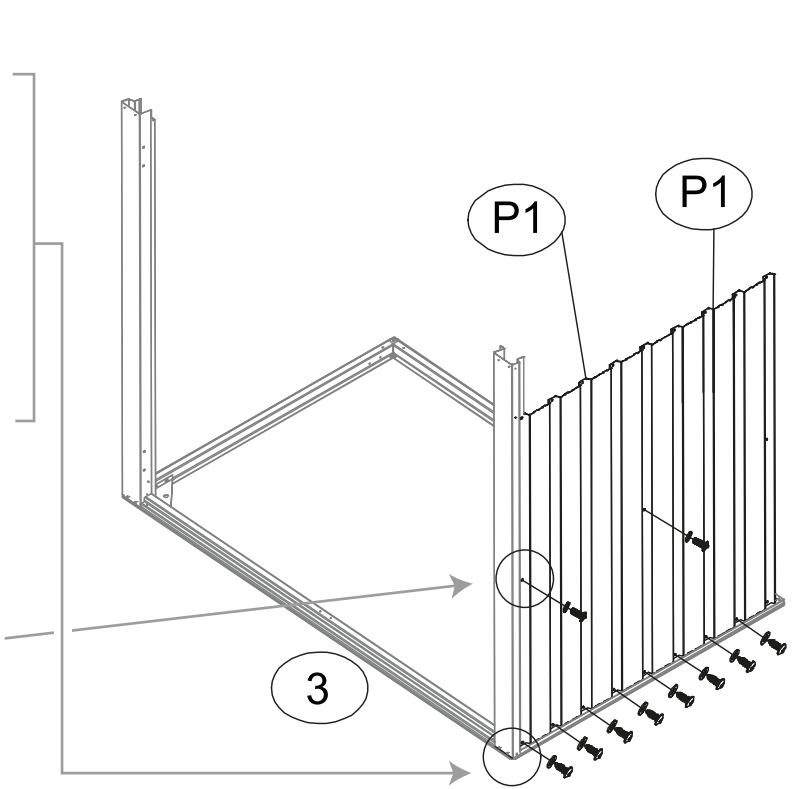
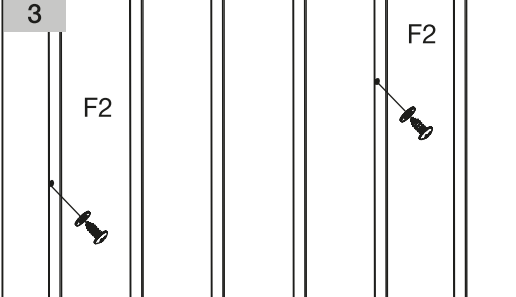

B-04

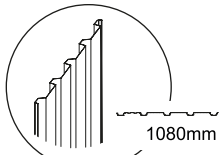

P2 x 1

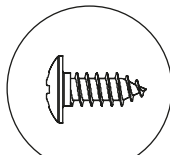

F1 x 5

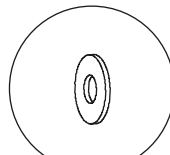

S3 x 5

1

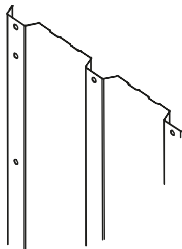

2

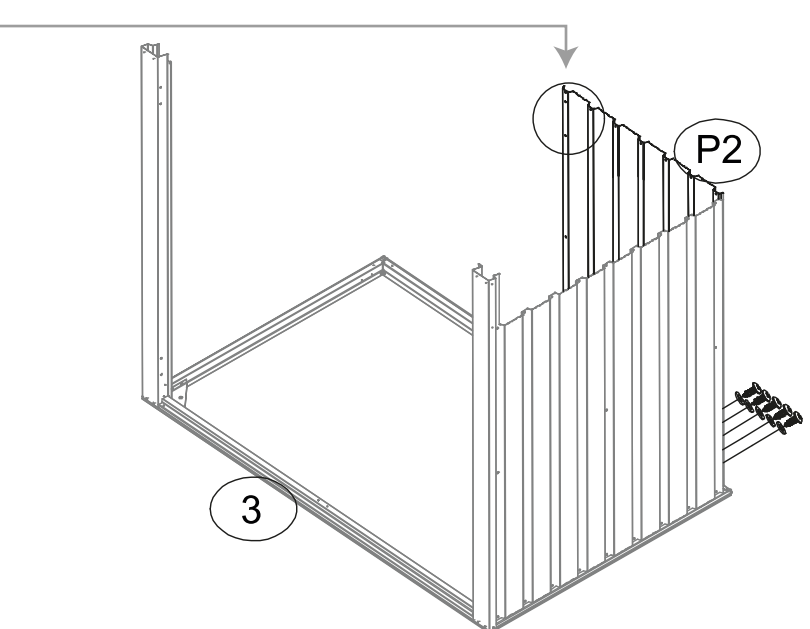
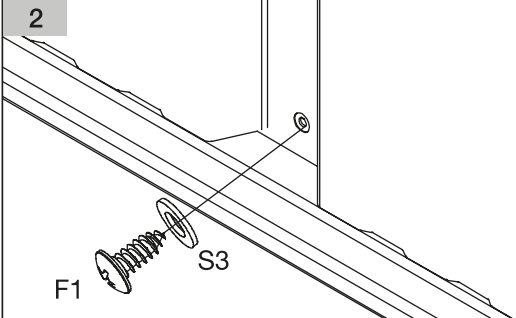

B-05

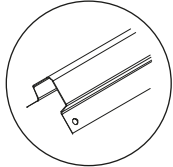

13 x 1

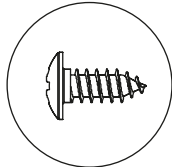

F1 x 2

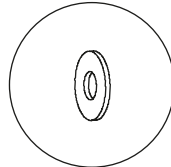

S3 x 4

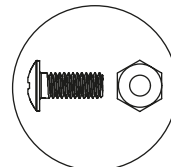

F2 x 2

1

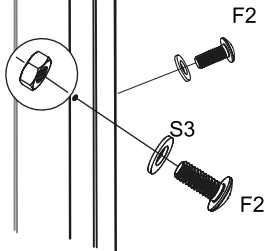

2

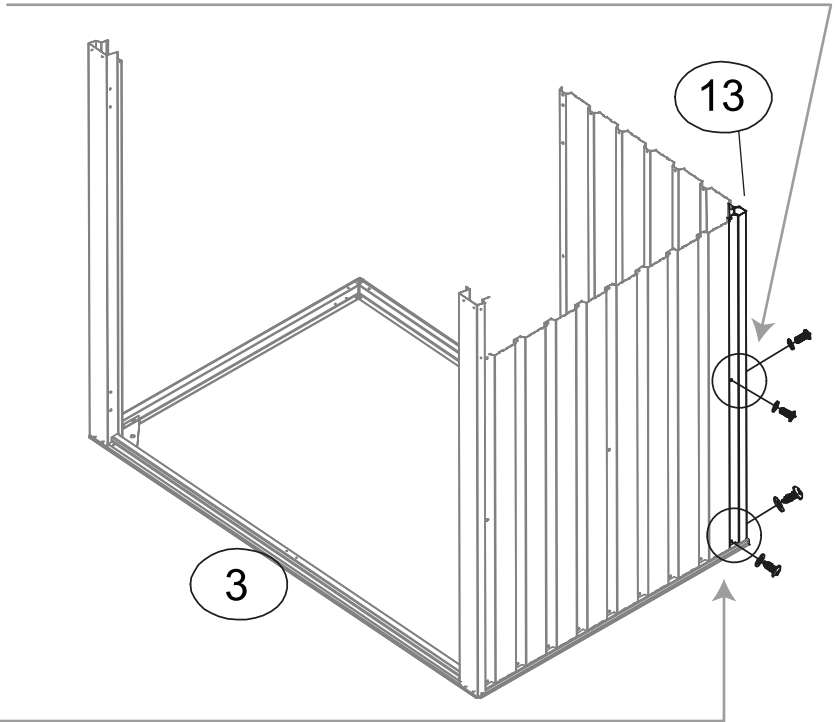
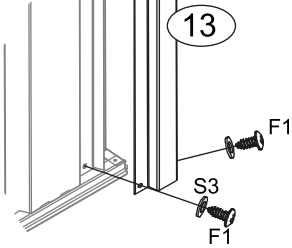

B-06

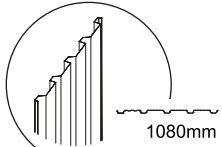

P3 x 1

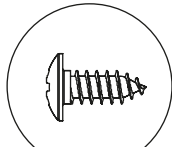

F1 x 5

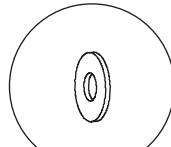

S3 x 5

1

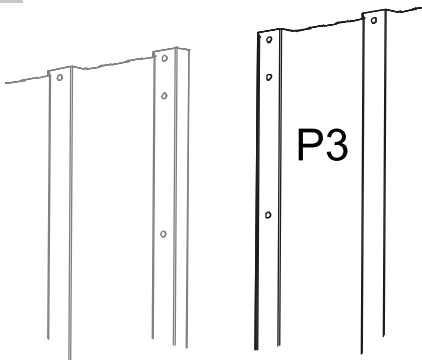

2

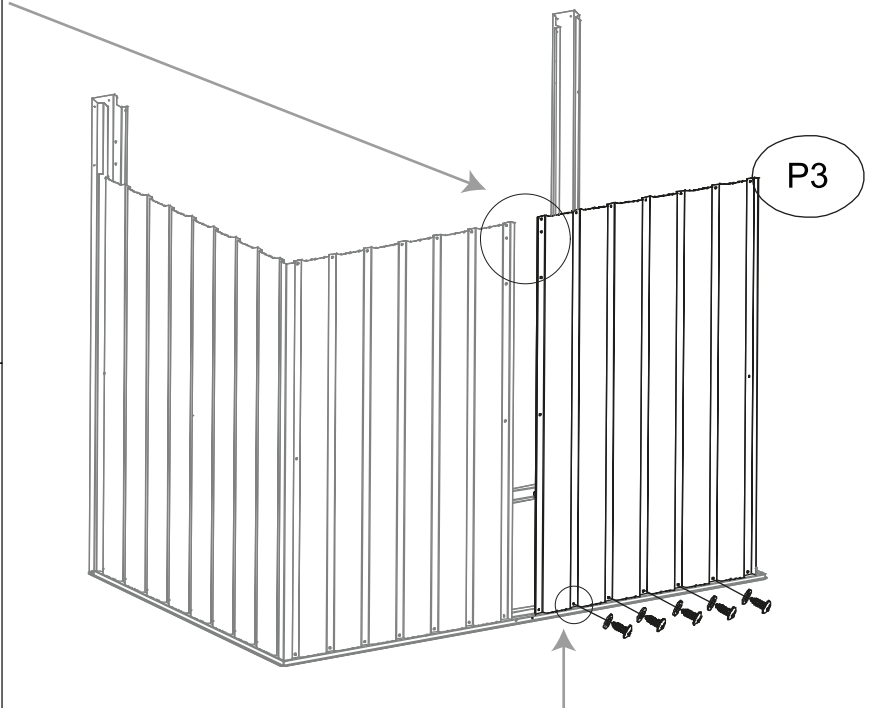
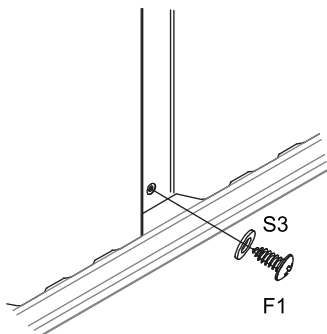

B-07

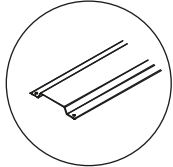

14 x 1

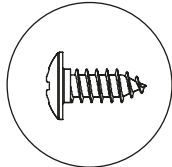

F1 x 4

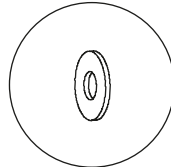

S3 x 6

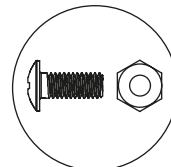

F2 x 2

1

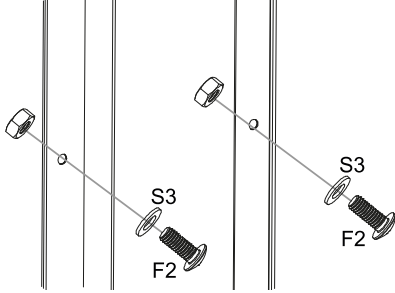

2

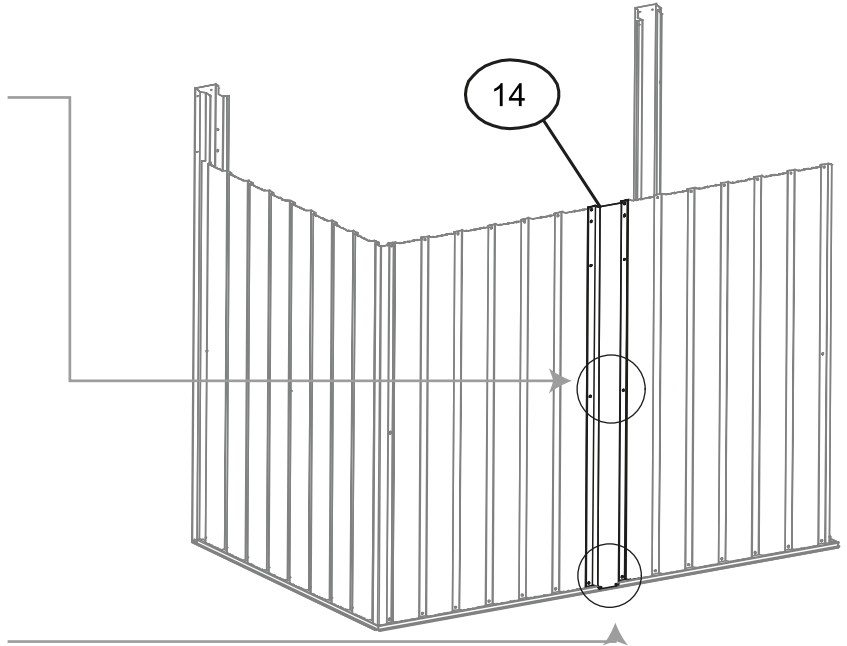
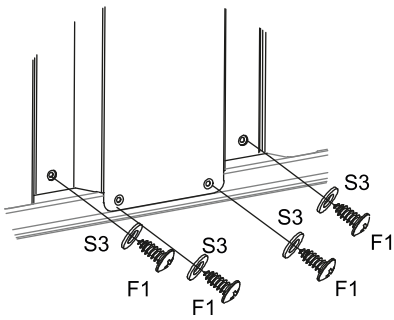

B-08

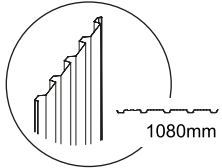

P1 x 2

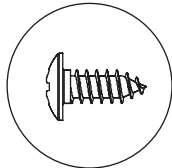

F1 x 8

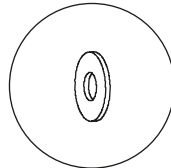

S3 x 10

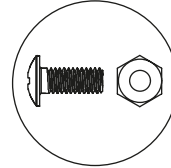

F2 x 2

1

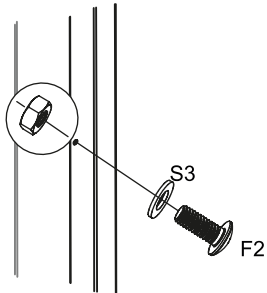

2

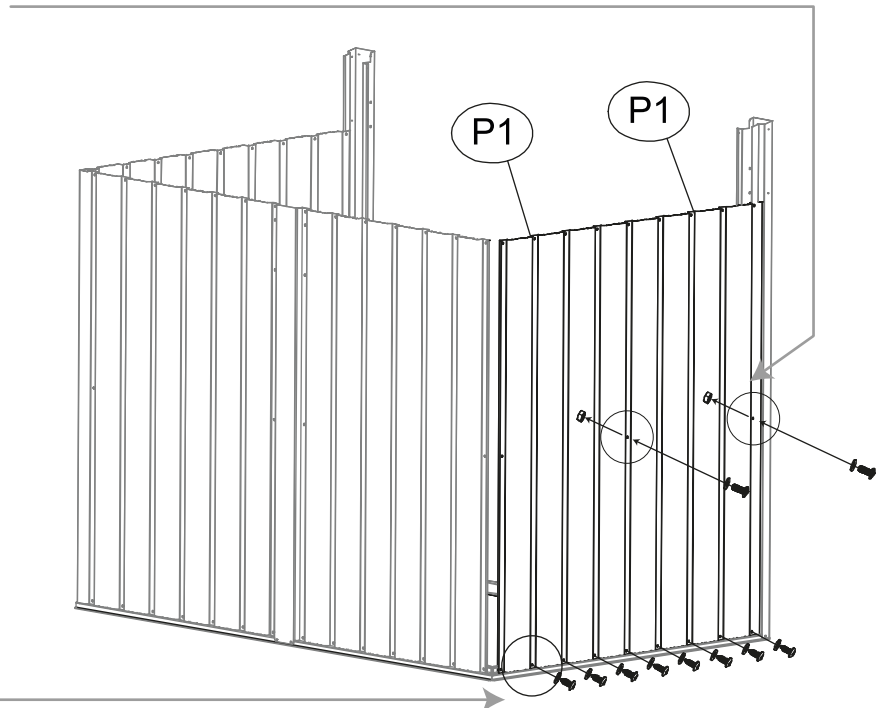
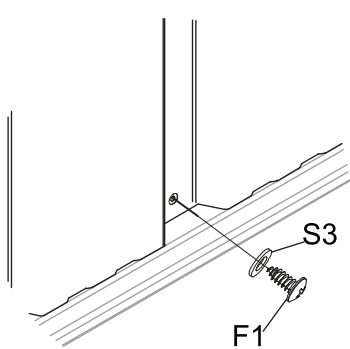

B-09

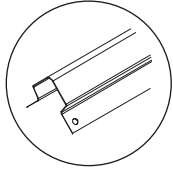

13 x 1

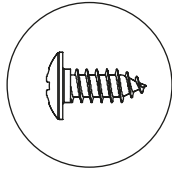

F1 x 2

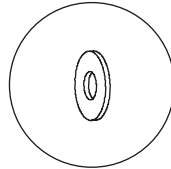

S3 x 4

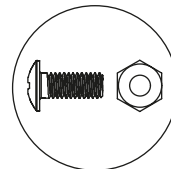

F2 x 2

1

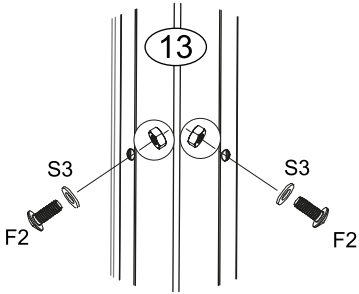

2

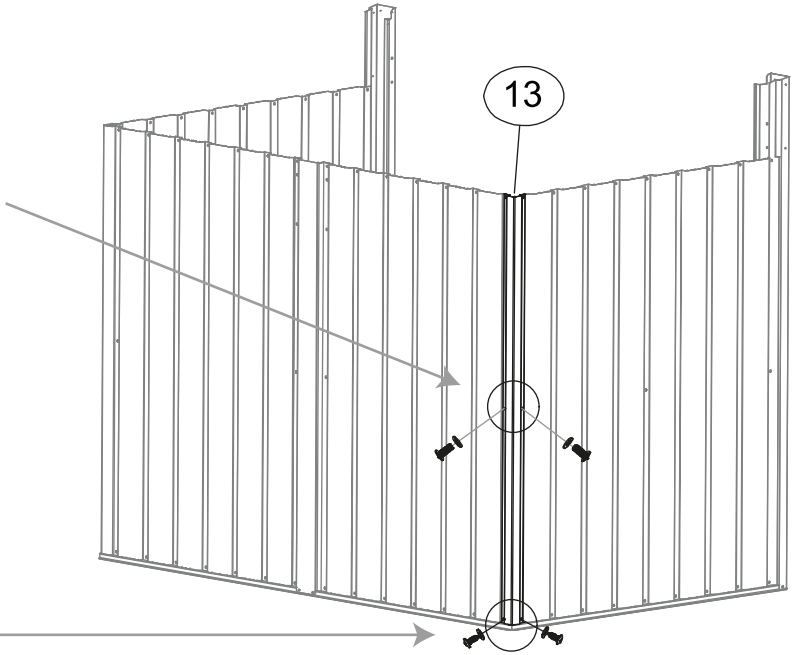
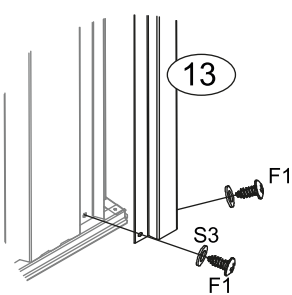

B-10

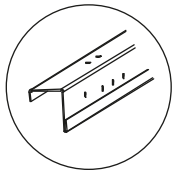

19 x 1

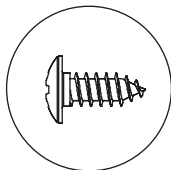

F1 x 14

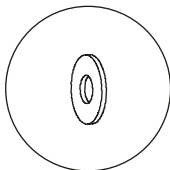

S3 x 14

1

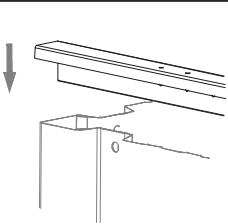

2

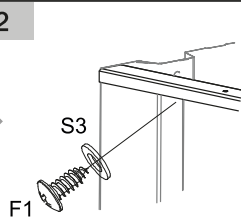

3

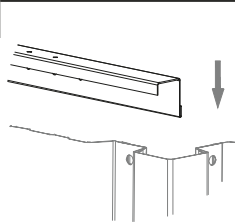

4

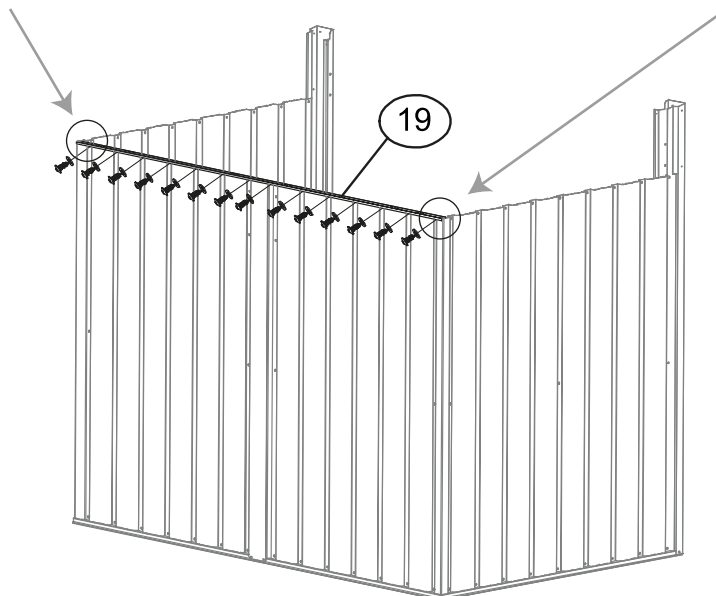
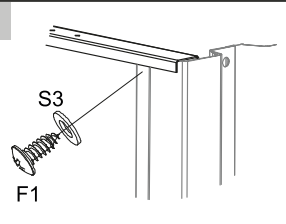

B-11

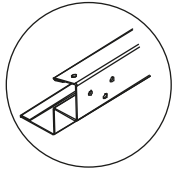

20 x 1

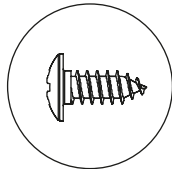

F1 x 8

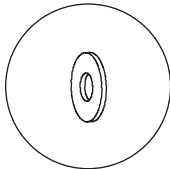

S3 x 8

1

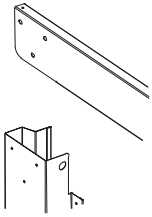

2

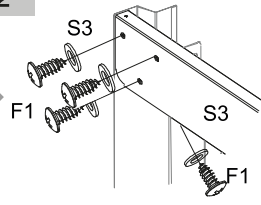

3

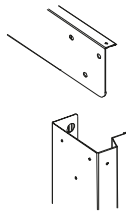

4

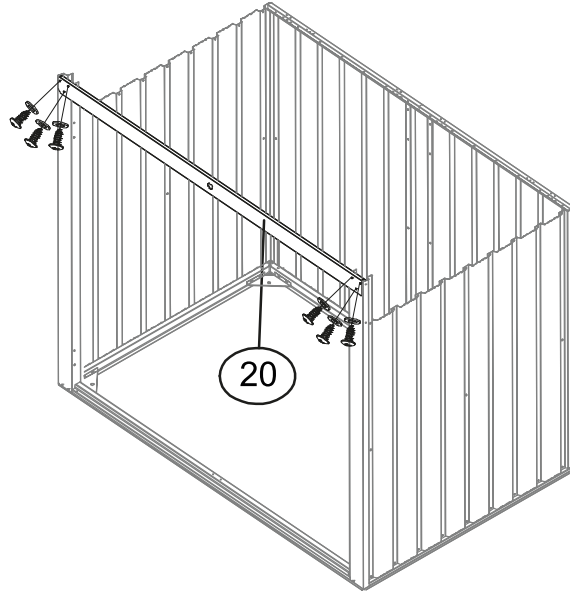
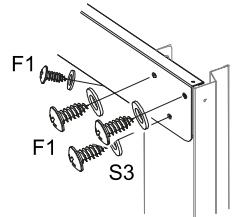

B-12

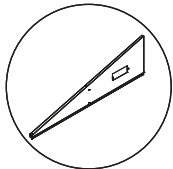

15 x 1

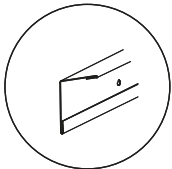

17 x 1

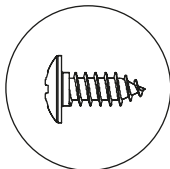

F1 x 12

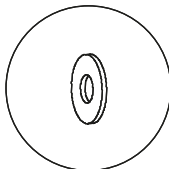

S3 x 12

1

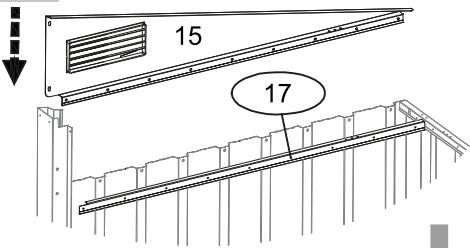

2

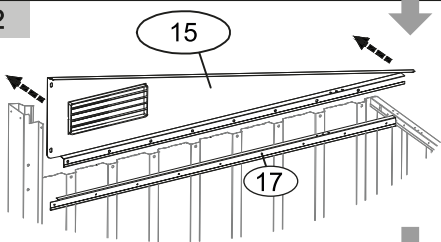

3

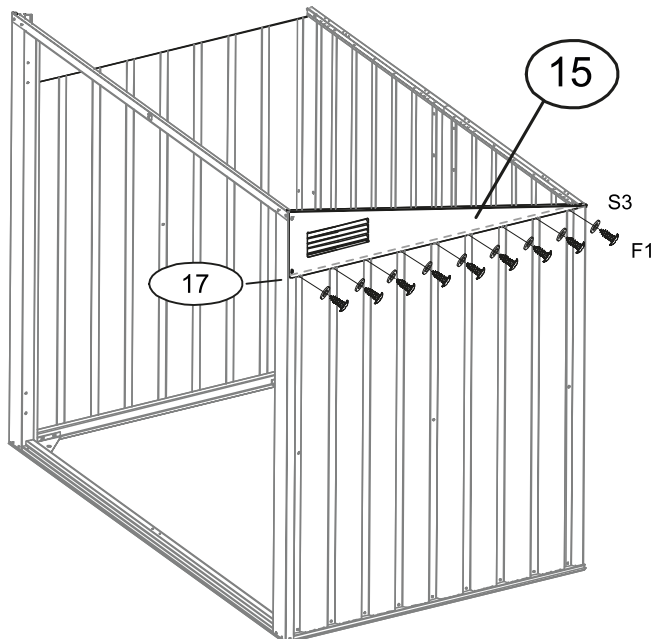
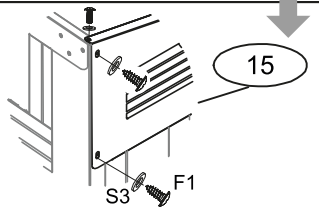

B-13

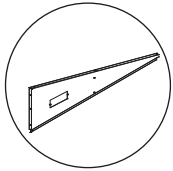

16 x 1

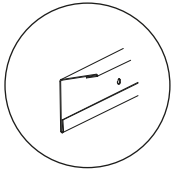

18 x 1

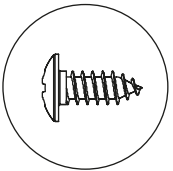

F1 x 12

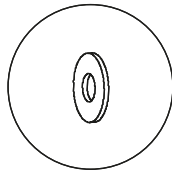

S3 x 12

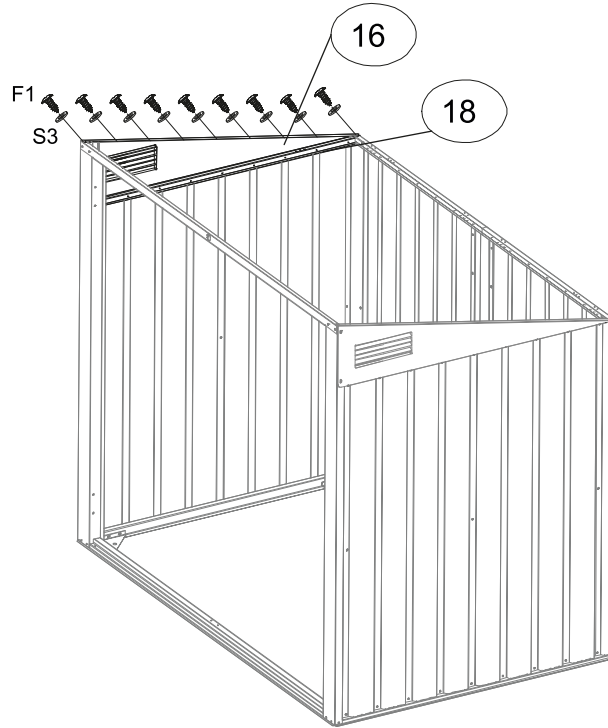
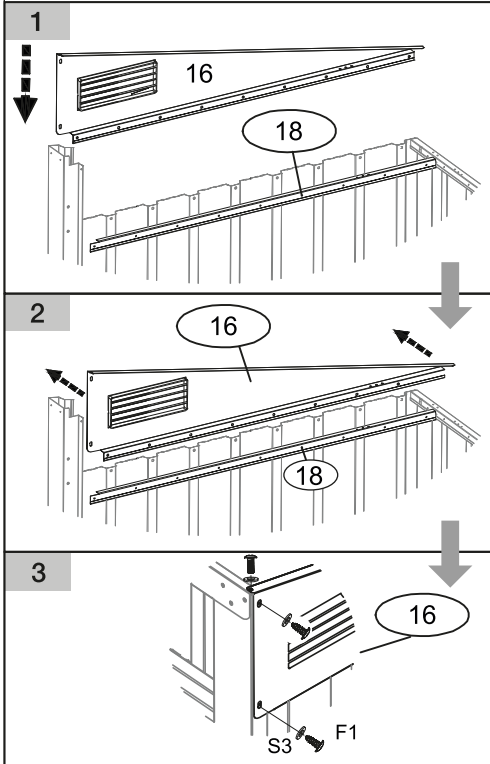

B-14

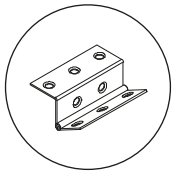

W1 x 4

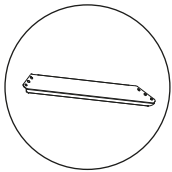

K1 x 2

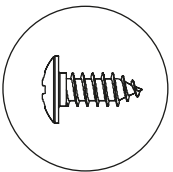

F1 x 32

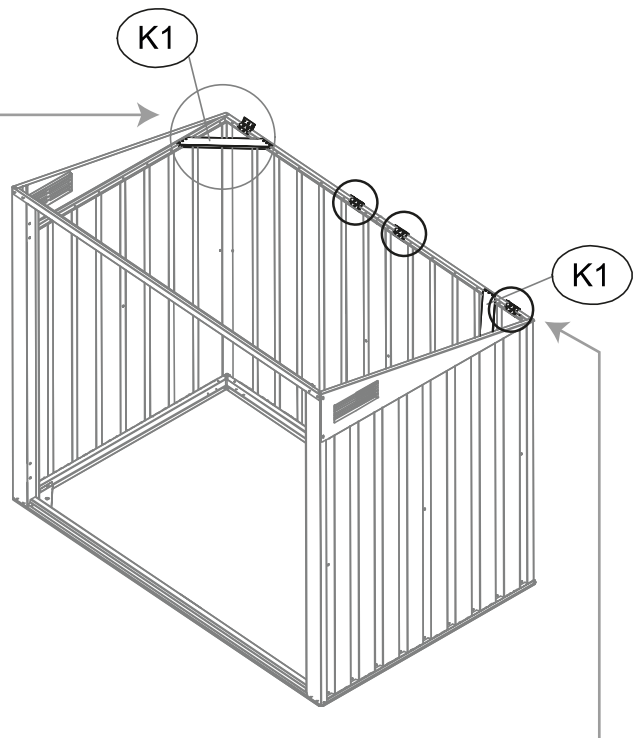
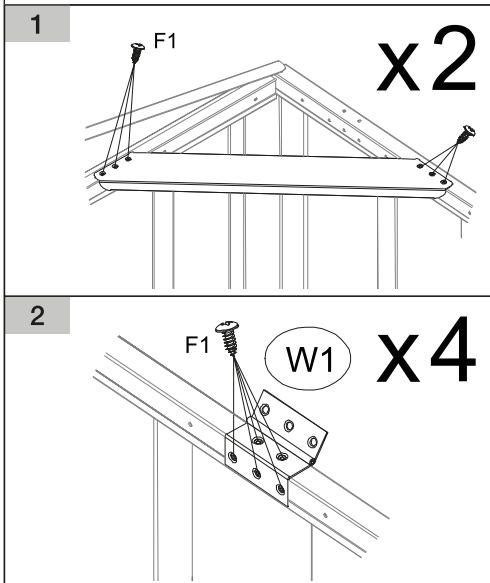

B-15

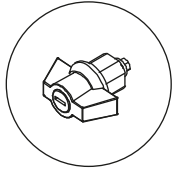

B4 x 1

1

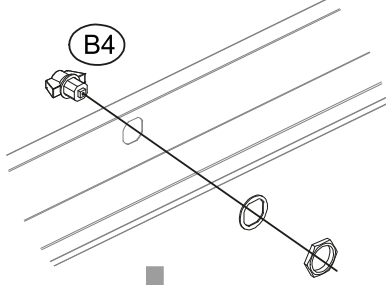

2

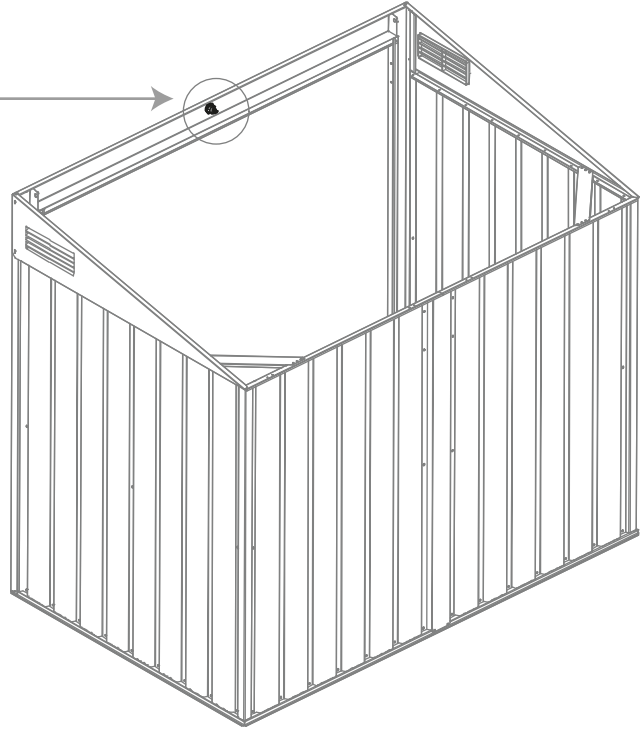
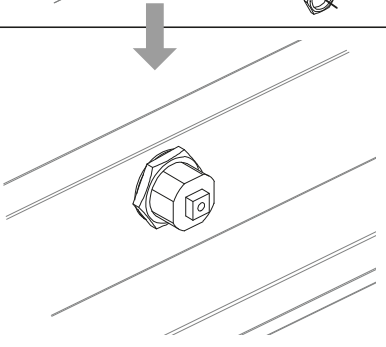

B-16

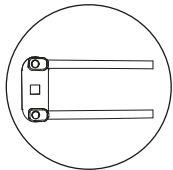

B2 x 1

1

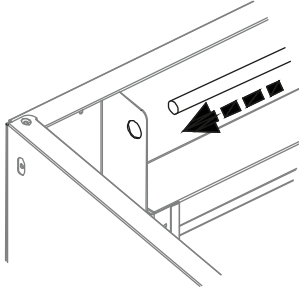

2

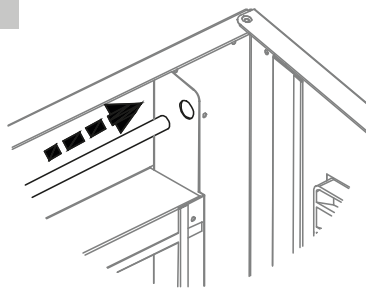

3

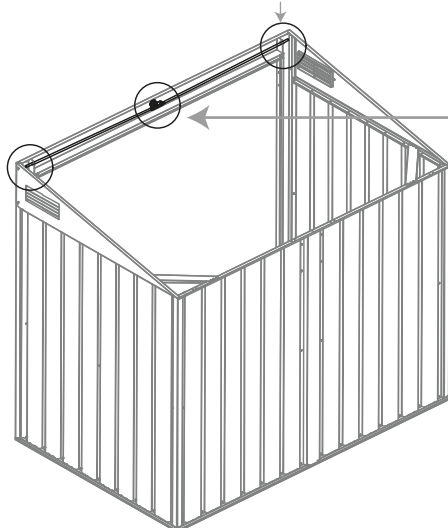
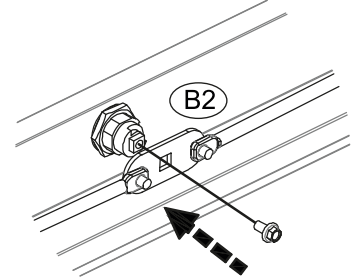

C-01

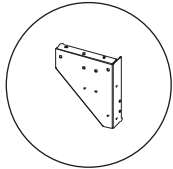

29 x 4

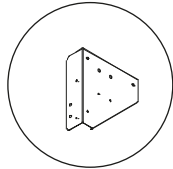

29-1 x 4

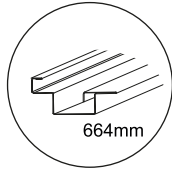

40 x 4
664mm

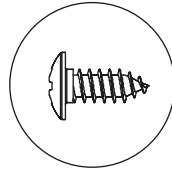

F1 x 32

x4

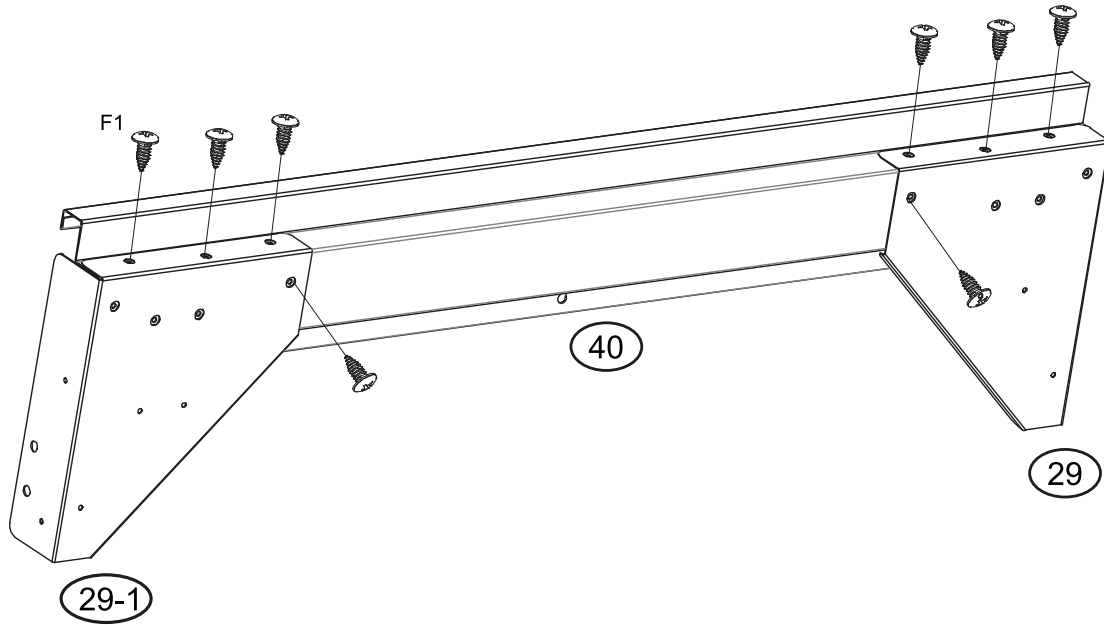

C-02

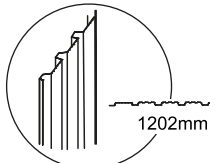

D1 x 1

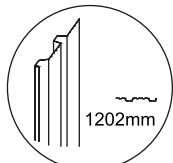

D2 x 1

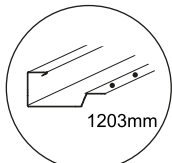

41 x 1

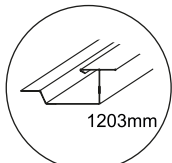

42 x 1

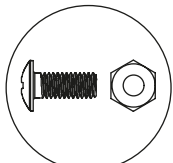

F2 x 3

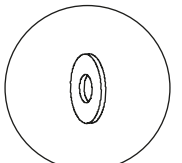

S3 x 3

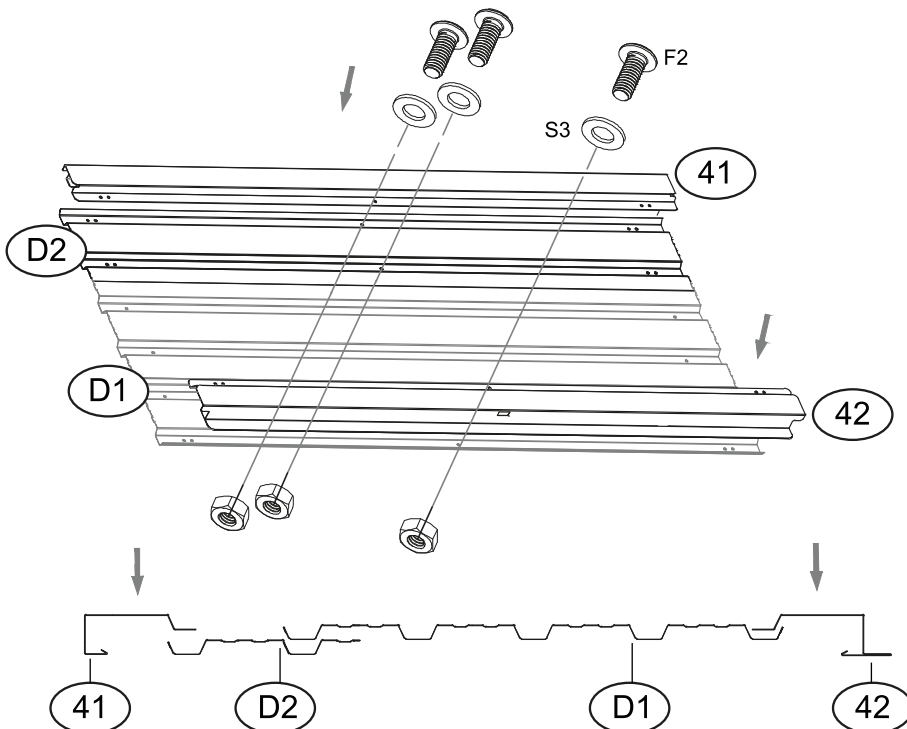

C-03

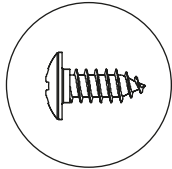

F1 x 14

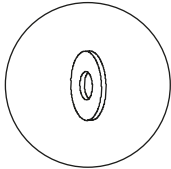

S3 x 18

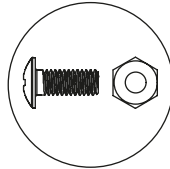

F2 x 4

1

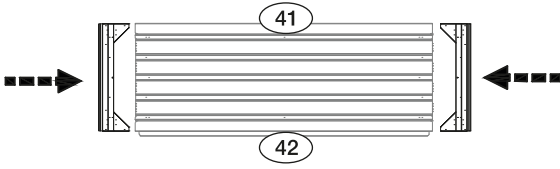

2

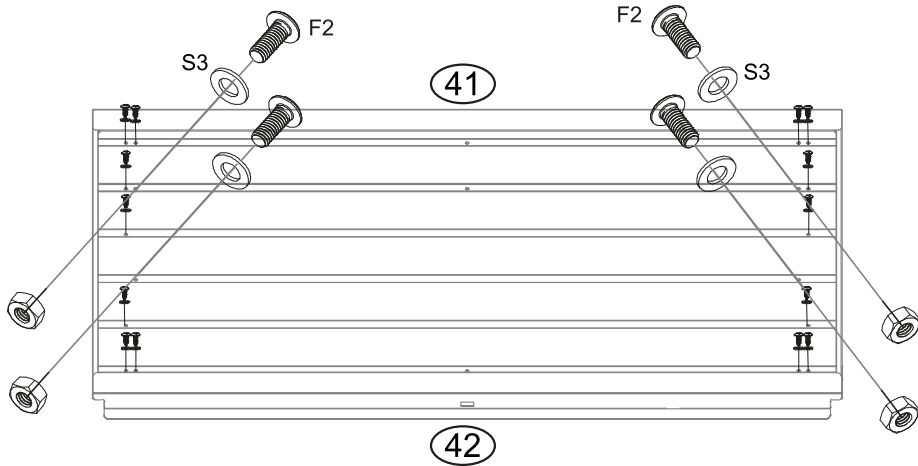
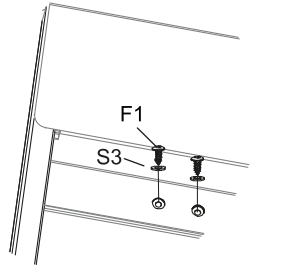

C-04

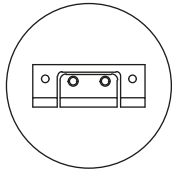

G4 x 2

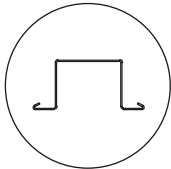

55 x 1

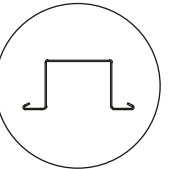

56 x 1

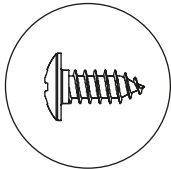

F1 x 16

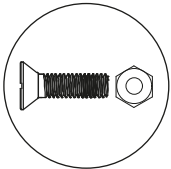

F3 x 4

1

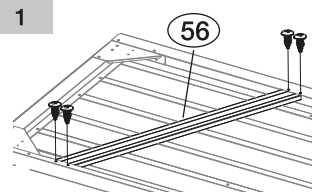

2

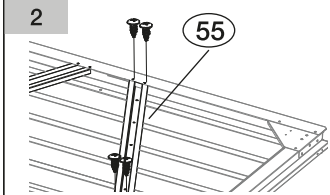

3

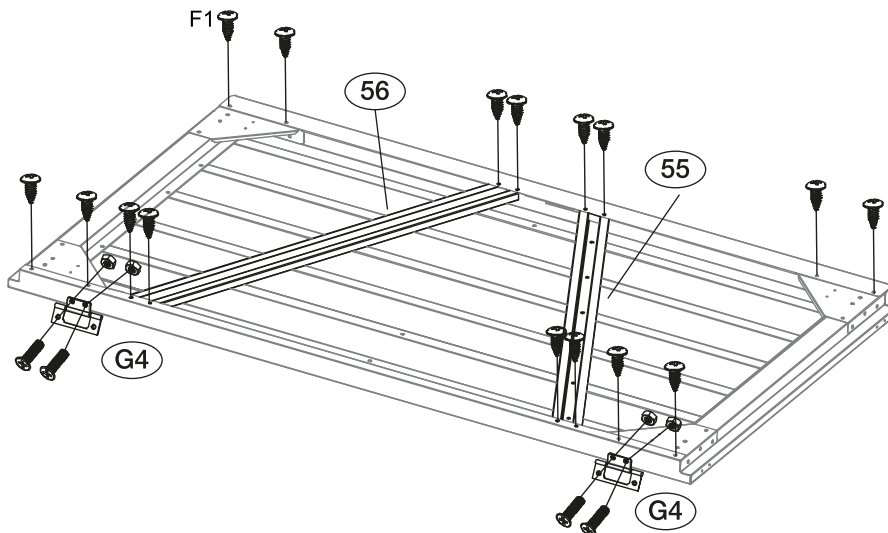
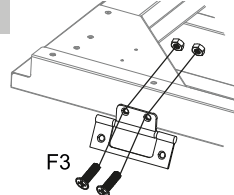

C-05

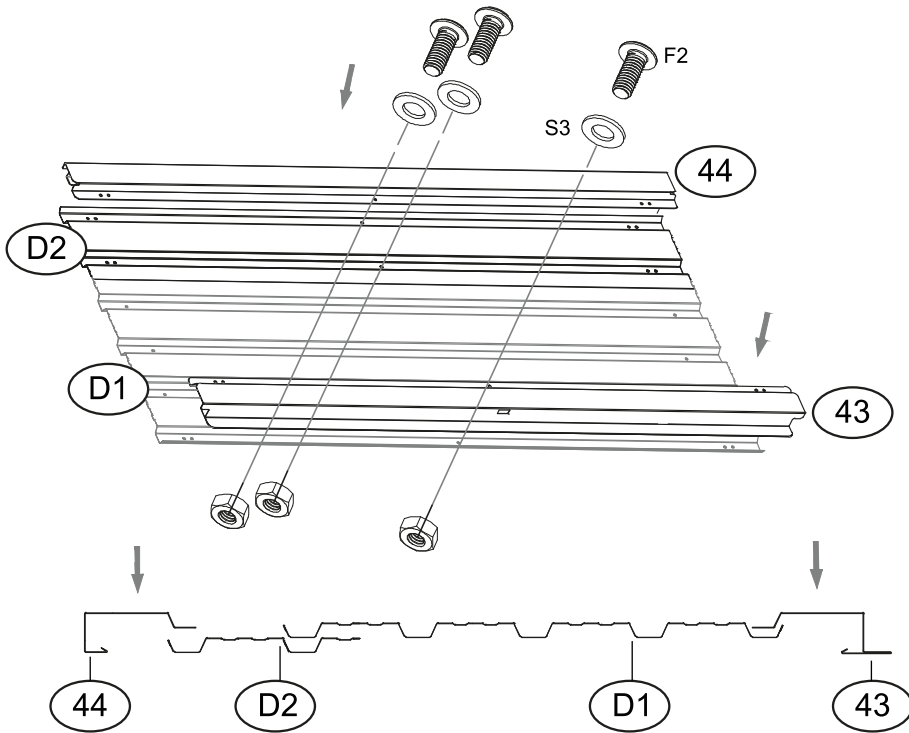
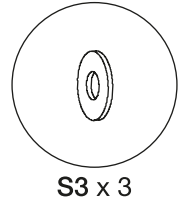
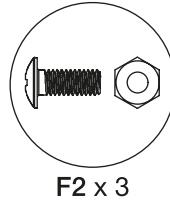
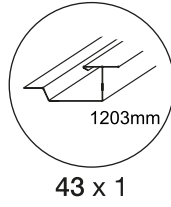
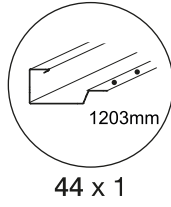
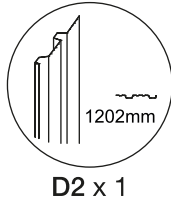
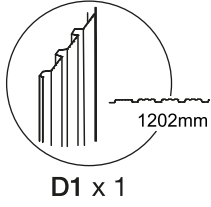

C-06

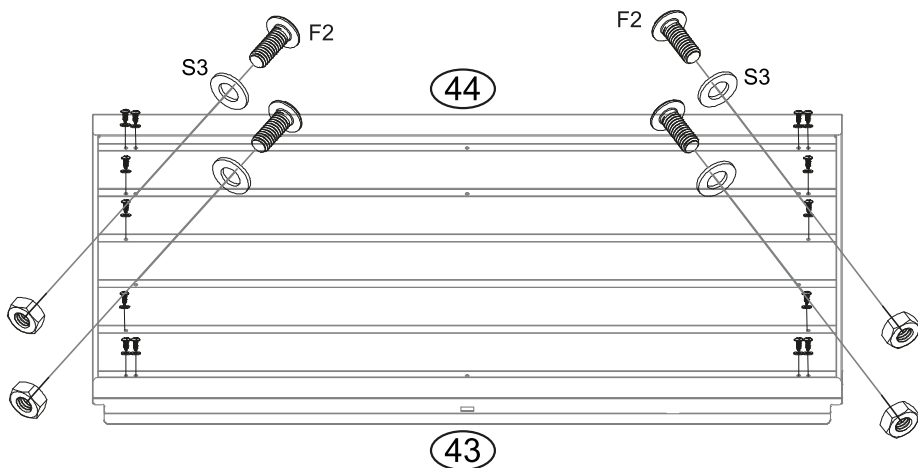
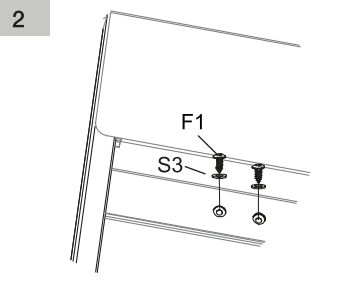
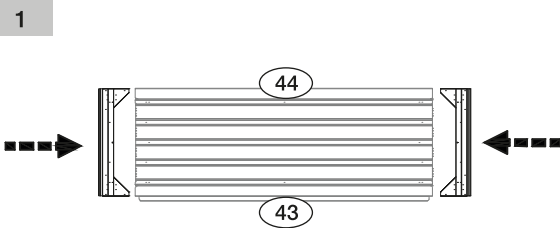
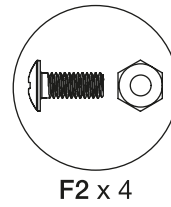
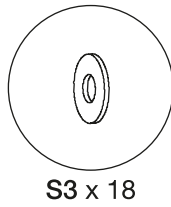
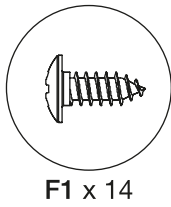

C-07

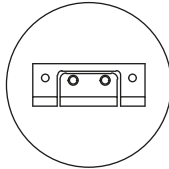

G4 x 2

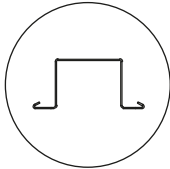

55 x 1

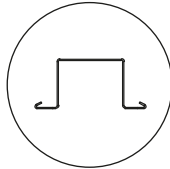

56 x 1

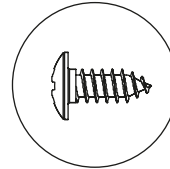

F1 x 16

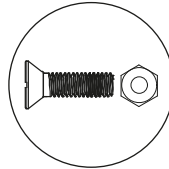

F3 x 4

1

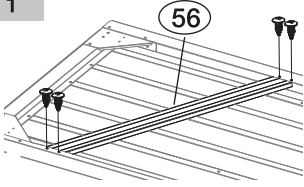

2

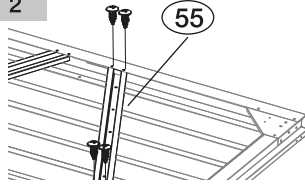

3

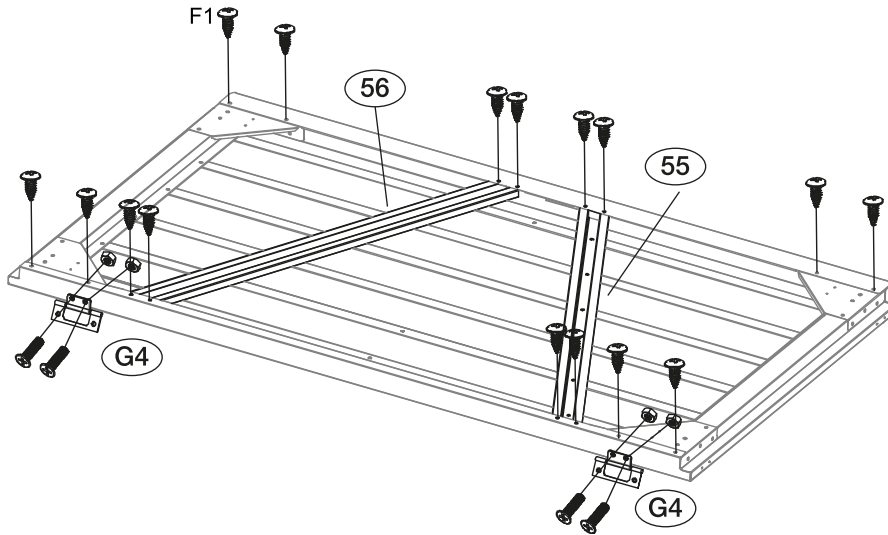
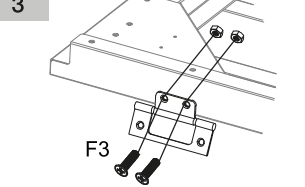

C-08

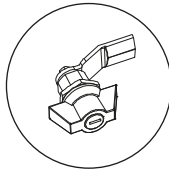

B1 x 1

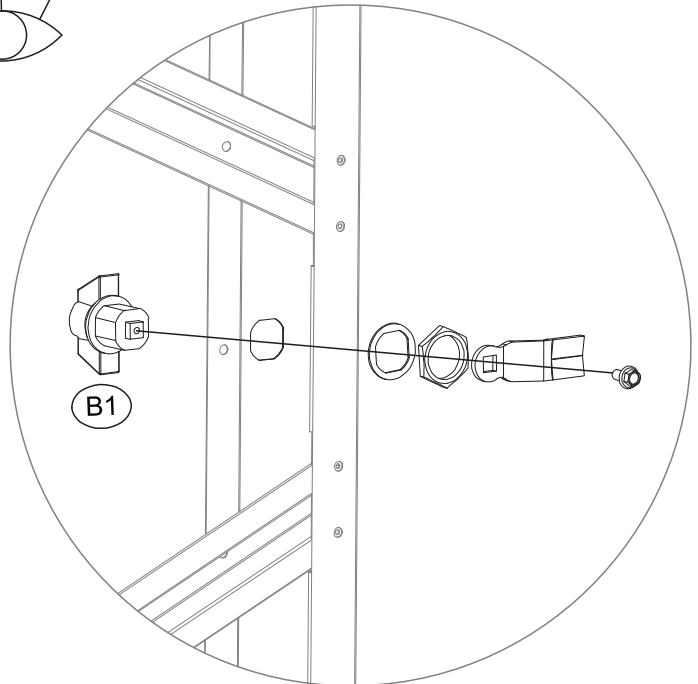
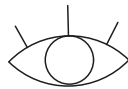
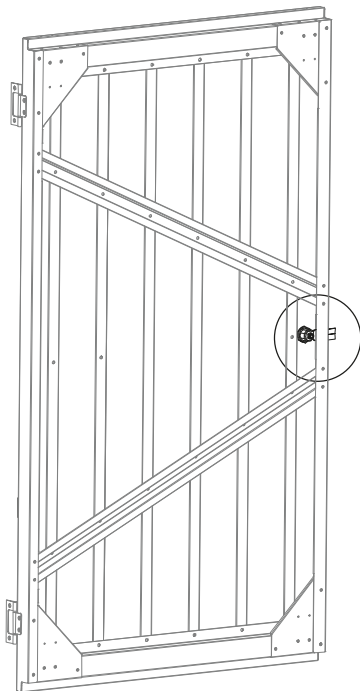

C-09

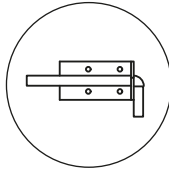

G6 x 2

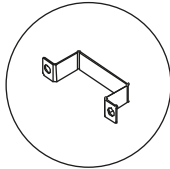

65 x 1

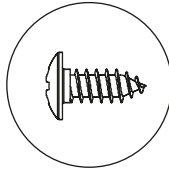

F1 x 10

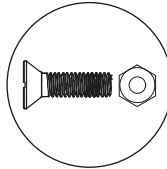

F3 x 8

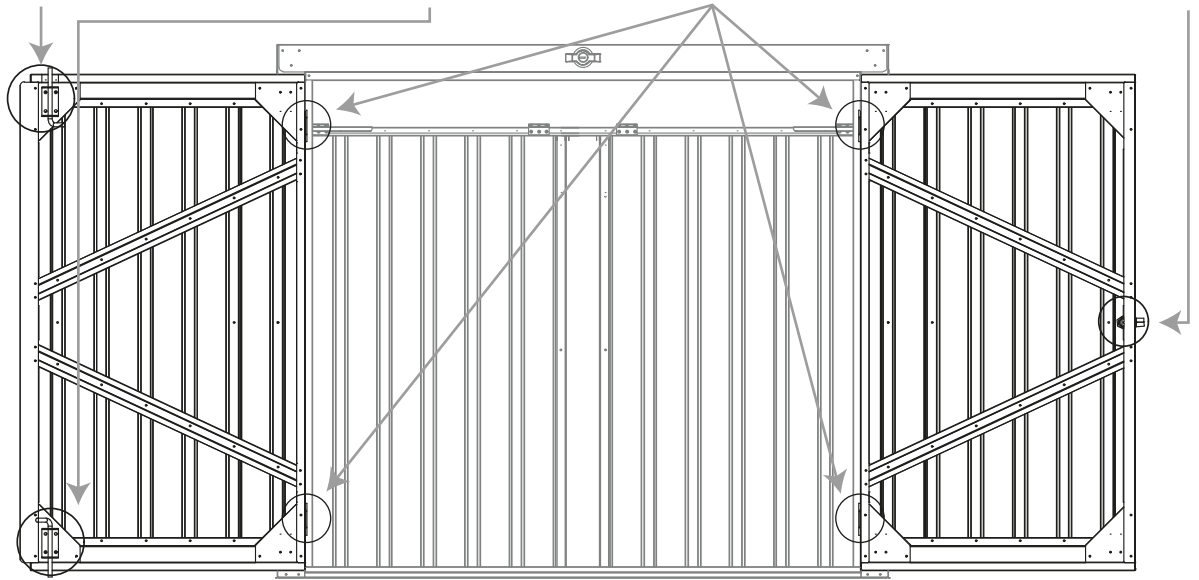
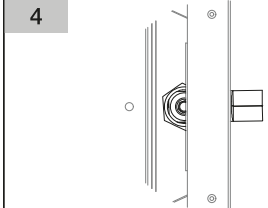
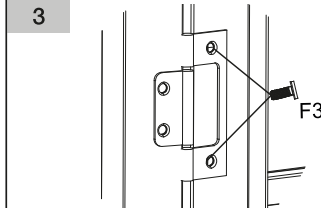
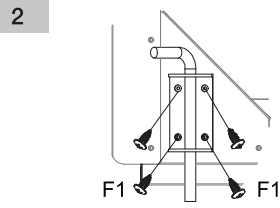
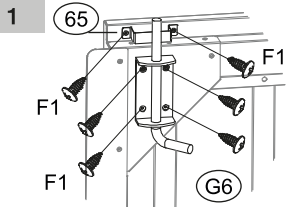

D-01

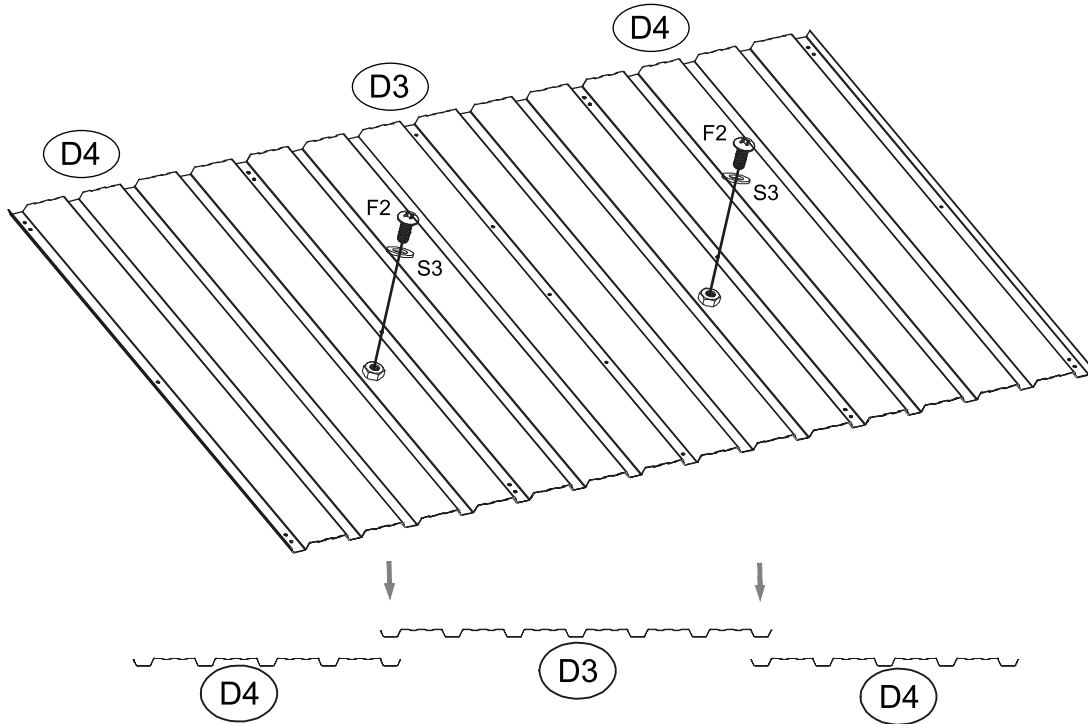
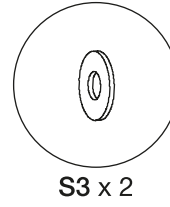
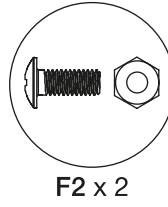
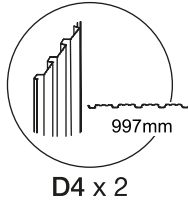
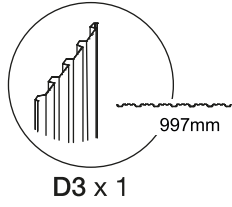

D-02

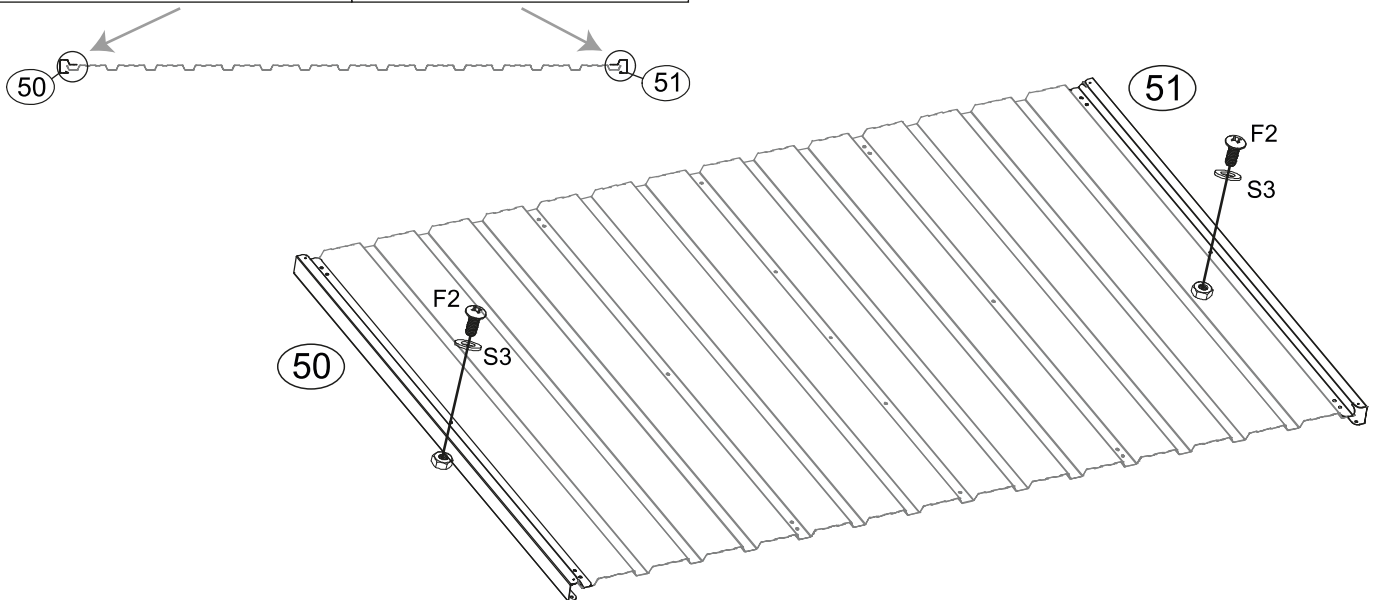
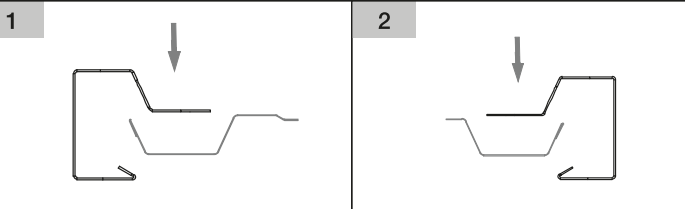
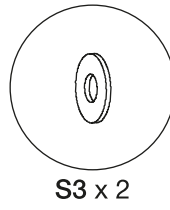
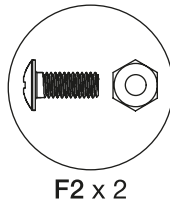
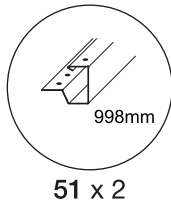
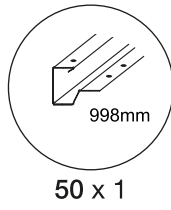

D-03

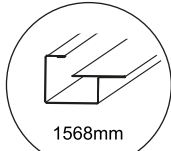

1568mm

48 x 1

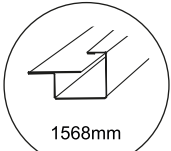

1568mm

49 x 1

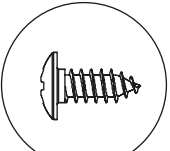

F1 x 18

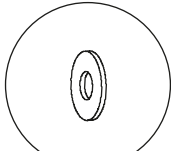

S3 x 18

1

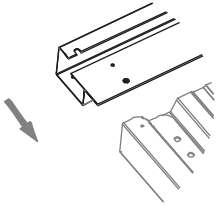

2

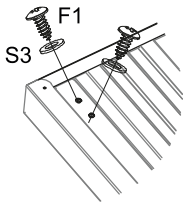

3

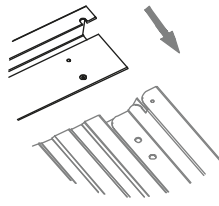

4

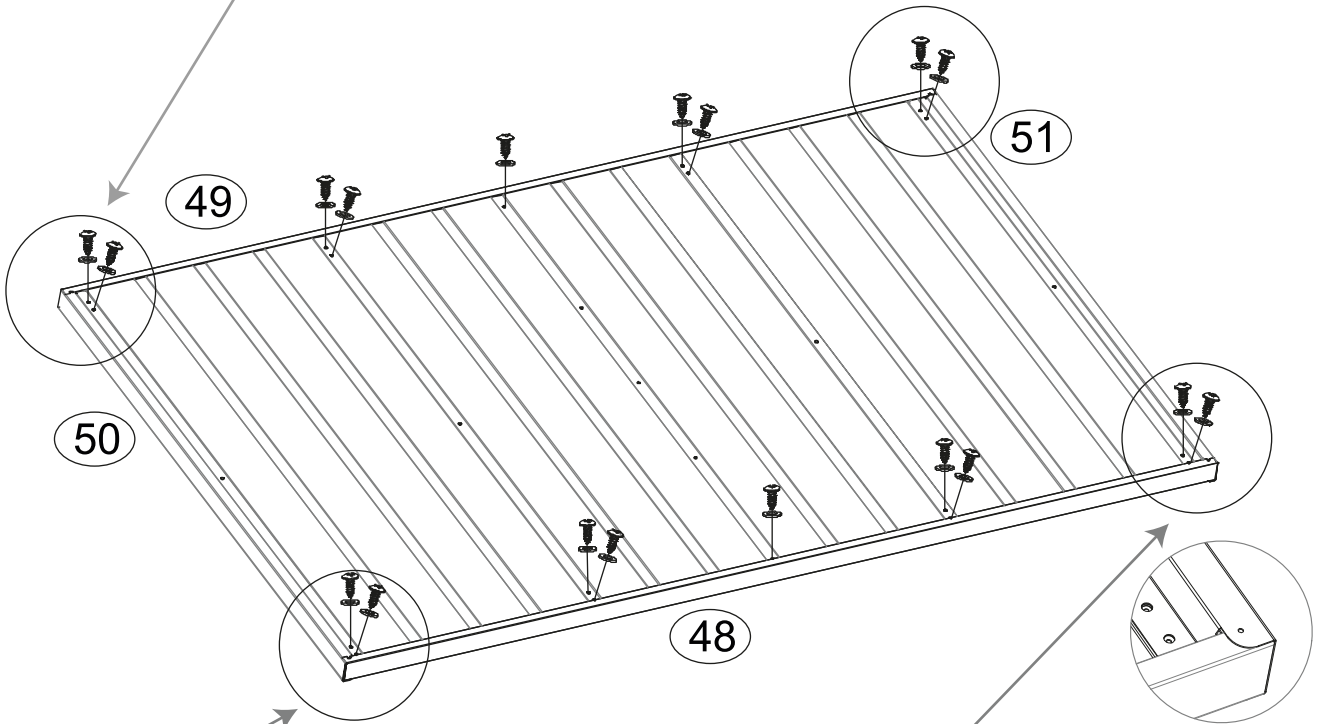
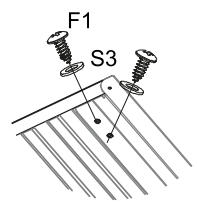

5

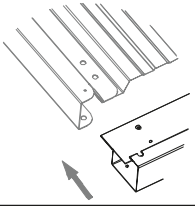

6

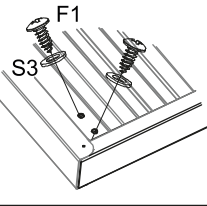

7

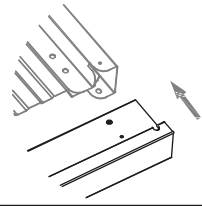

8

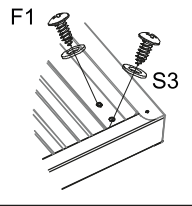

D-04

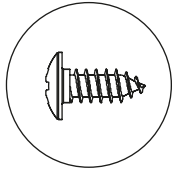

F1 x 8

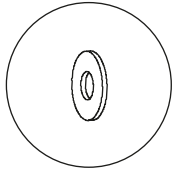

S3 x 8

1

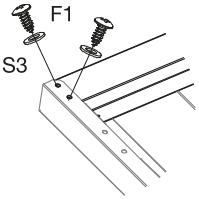

2

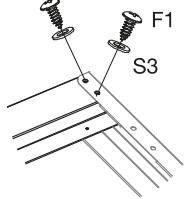

3

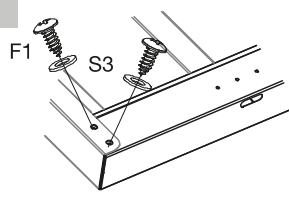

4

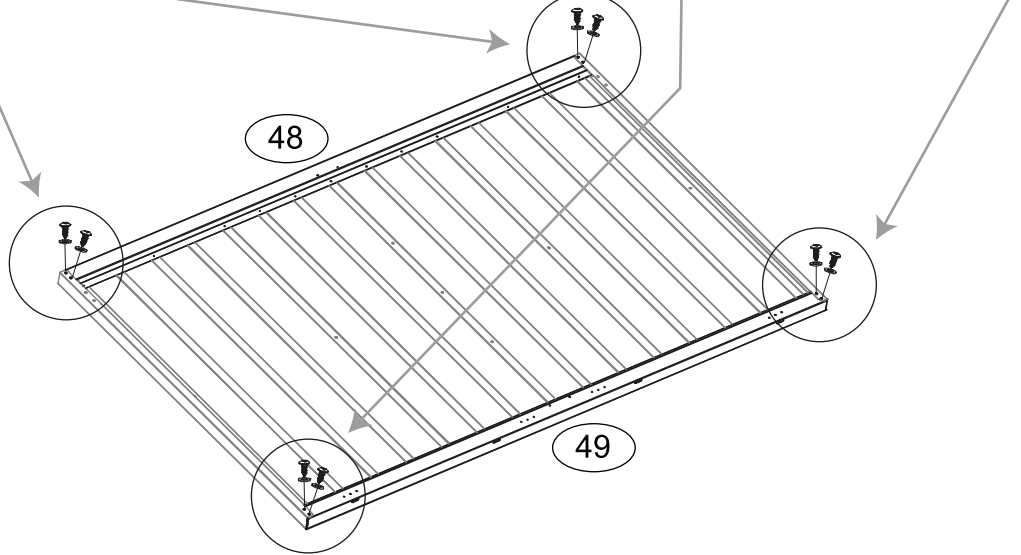
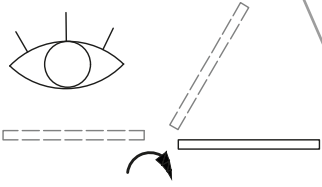
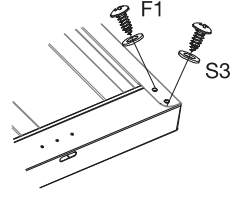

D-05

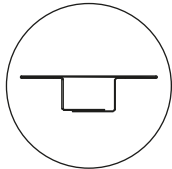

52 x 1

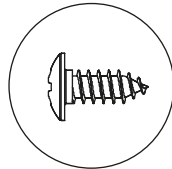

F1 x 4

1

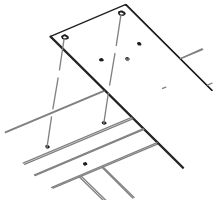

2

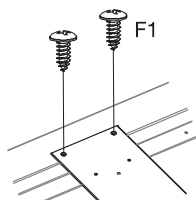

3

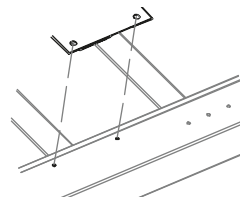

4

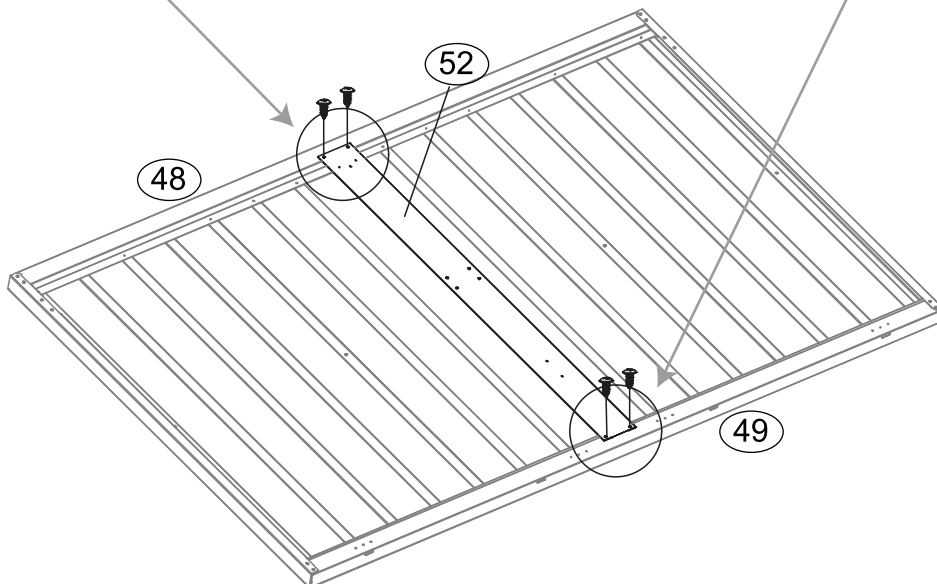
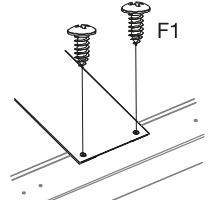

D-06

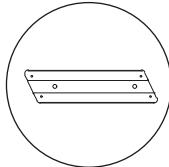

53 x 8

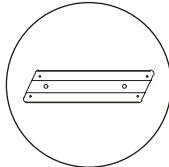

54 x 8

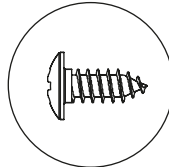

F1 x 8

1

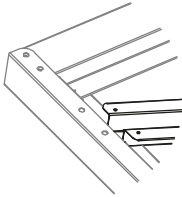

2

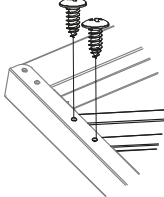

3

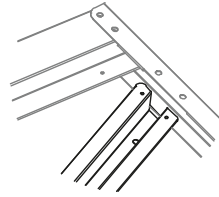

4

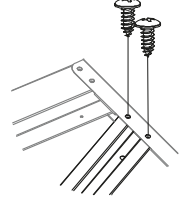

5

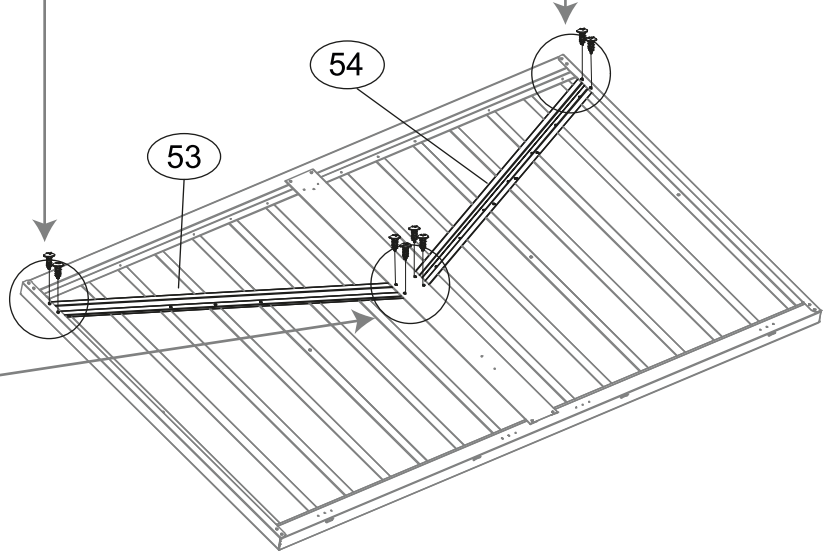
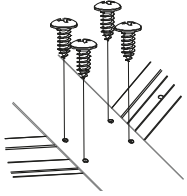

D-07

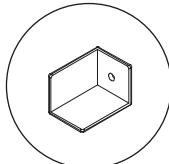

GC x 4

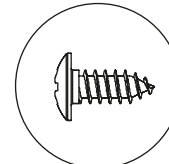

F1 x 9

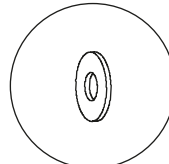

S3 x 5

1

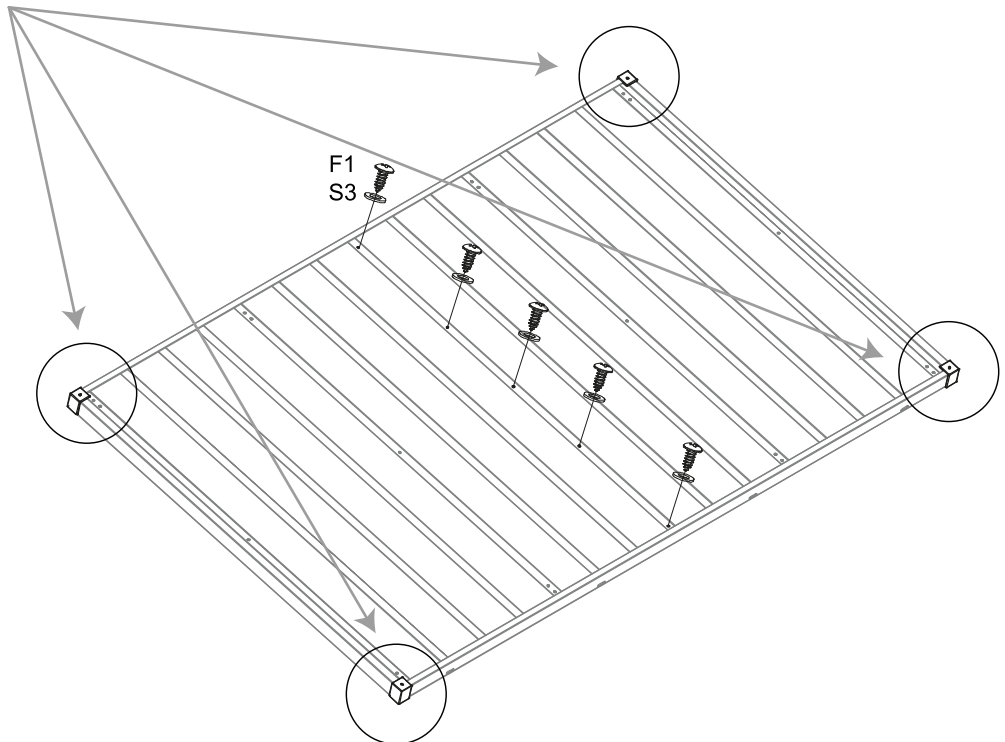
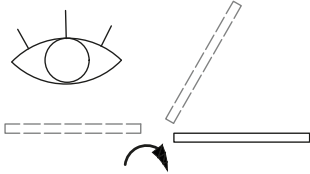
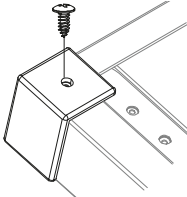

D-08

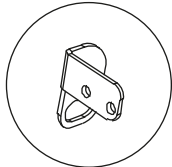

BL x 1

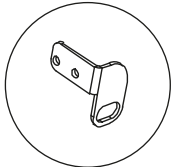

BR x 1

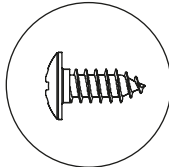

F1 x 4

1

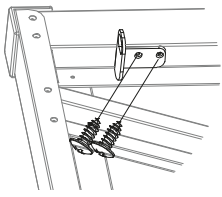

2

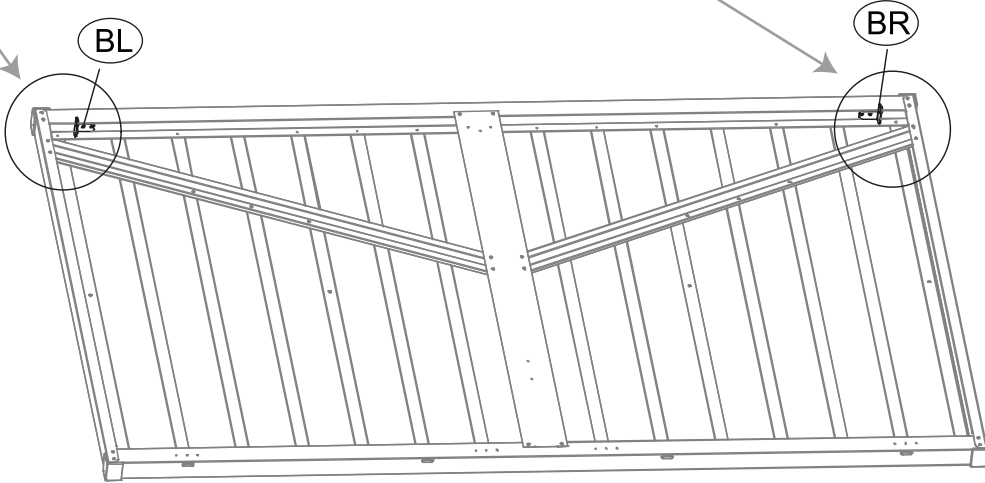
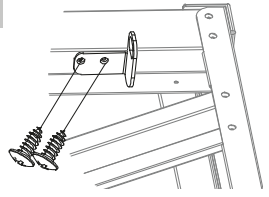

D-09

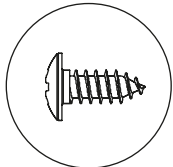

F1 x 12

1

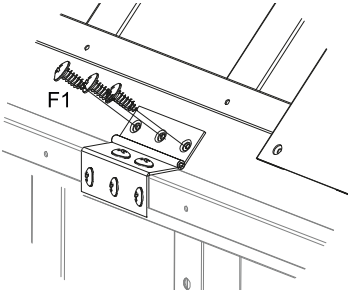

x4

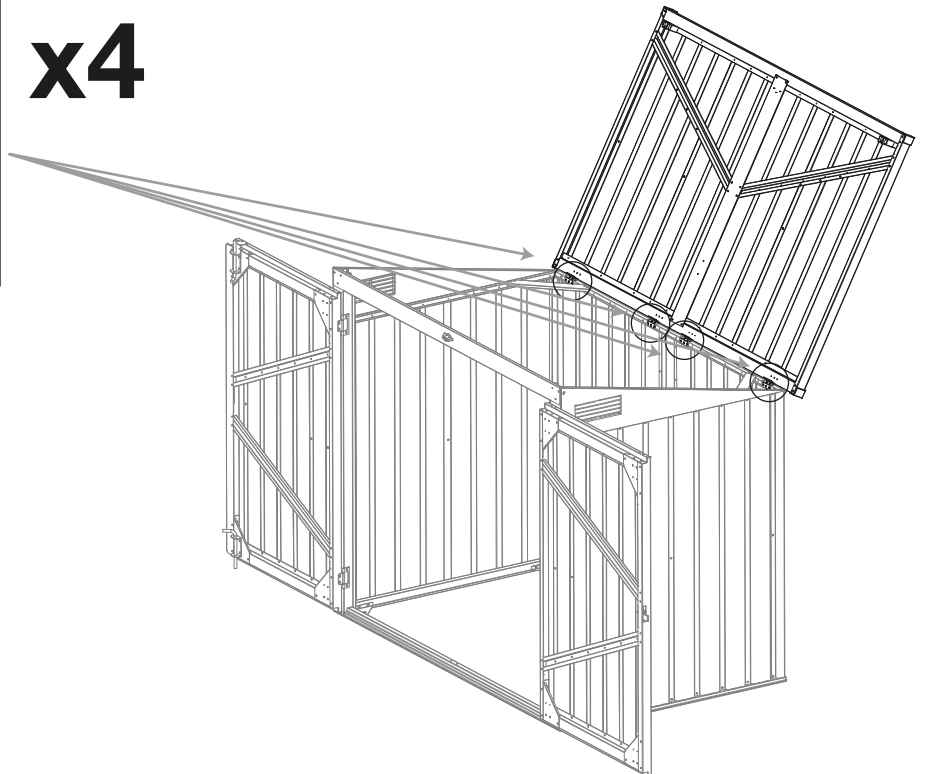

D-10

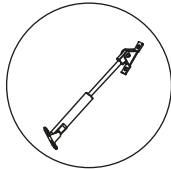

G3 x 1

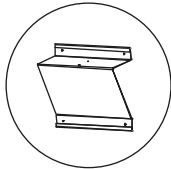

32 x 1

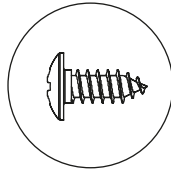

F1 x 2

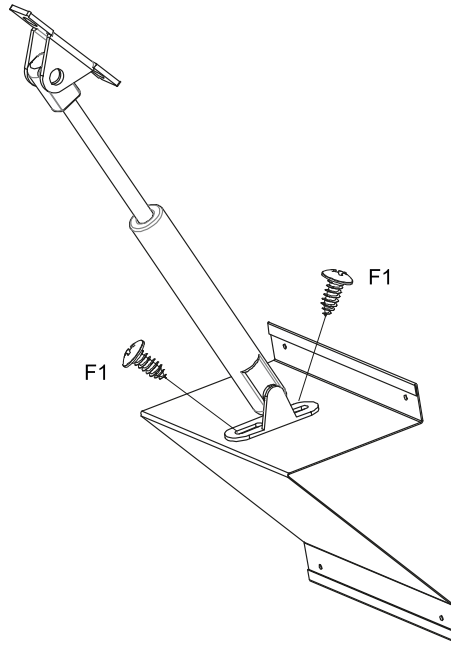

D-11

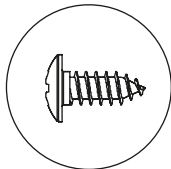

F1 x 6

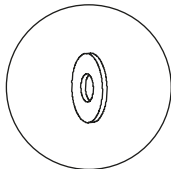

S3 x 4

1

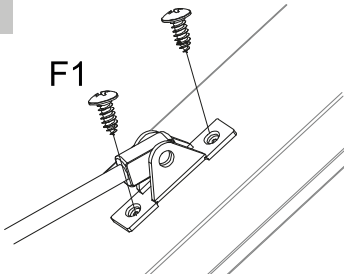

2

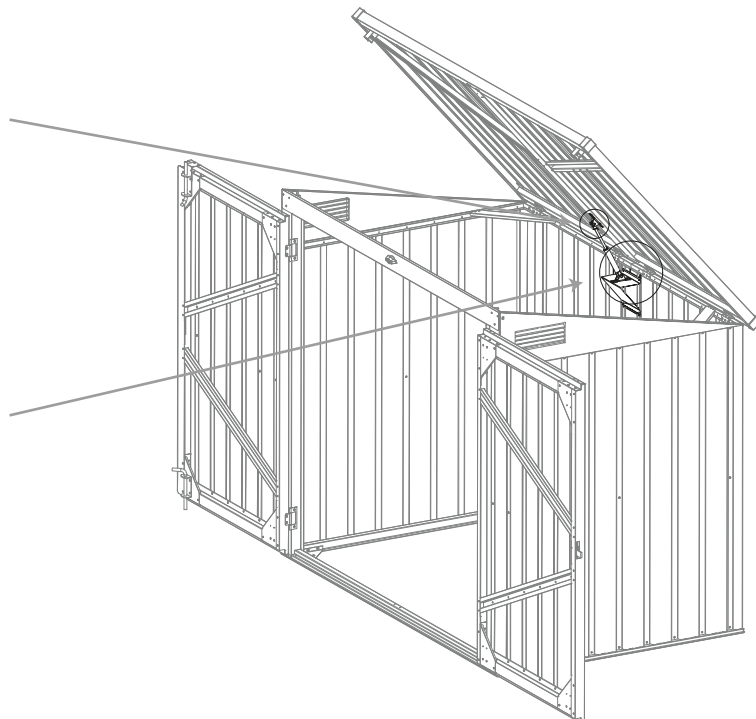
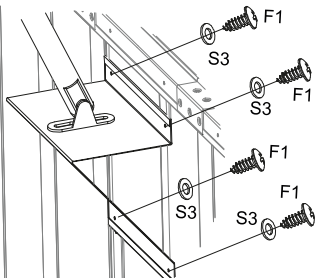

D-12

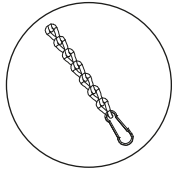

K2 x 2

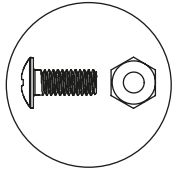

F2 x 2

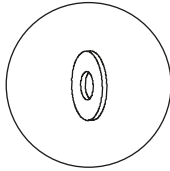

S3 x 2

1

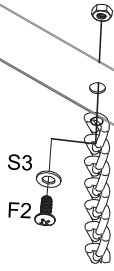

x2

