

ELEGANTO 2724

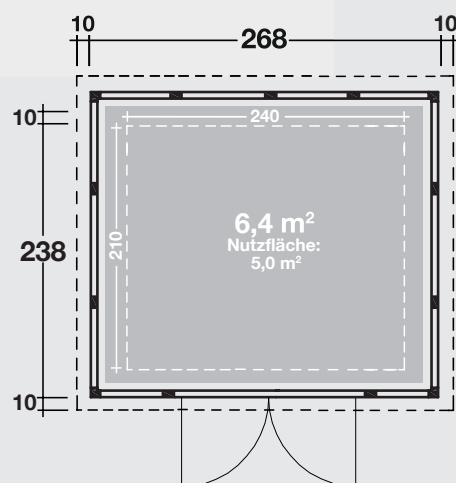

INSTRUCTIONS DE MONTAGE MONTAGE HANDLEIDING ASSEMBLY INSTRUCTIONS MONTAGEANLEITUNG



Projet numéro / Project nummer / Project number / Projekt Nummer :
.....

QC-numéro / QC-nummer / QC-number / QC-Nummer :
.....

Couleur / Kleur / Colour / Farbe:

- Blanc, Wit, White, Weiß
- Gris clair, Licht grijs, Light grey, Lichtgrau
- Anthracite, Antraciet, Anthracite, Granitgrau
- Granulé, StoneCoat, StoneCoat, Dekorputz

Nous vous invitons à lire attentivement le présent mode d'emploi.
 Vous y trouverez les caractéristiques techniques ainsi que toutes les informations utiles en vue d'un fonctionnement correct.
 Les données techniques figurant dans cette publication peuvent être modifiées à tout moment et sans avis préalable et ce, pour des raisons techniques ou commerciales..

Wij nodigen u uit deze handleiding aandachtig te lezen.
 Ze omvat de technische eigenschappen en alle nuttige informatie voor een correcte werking.
 De technische gegevens in deze publicatie kunnen om technische of commerciële redenen op elk moment en zonder voorafgaande kennisgeving worden gewijzigd.

Please read this manual carefully.
 It contains the technical properties and all the information required for correct operation.
 The technical data in this publication is subject to change for technical and/or commercial reasons at any time and without notice.

Bitte lesen Sie diese Anleitung sorgfältig durch.
 Sie enthält die technischen Eigenschaften und alle Informationen, die für einen korrekten Betrieb erforderlich sind.
 Die in dieser Publikation enthaltenen technischen Daten können jederzeit ohne Vorankündigung aus technischen oder kommerziellen Gründen geändert werden.



Lisez bien l'ensemble du mode d'emploi avant de commencer à réaliser des travaux.

Lees de volledige handleiding voordat u begint met de werken uit te voeren.

Read the entire manual before you start working.

Lesen Sie vor Arbeitsbeginn die gesamte Anleitung.



L'utilisation de gants est obligatoire.

Het gebruik van handschoenen is verplicht.

The use of gloves is mandatory.

Das Tragen von Handschuhen ist Pflicht.



L'utilisation de lunettes de protection est obligatoire.

Het gebruik van een veiligheidsbril is verplicht.

The use of safety glasses is mandatory.

Das Tragen einer Sicherheitsbrille ist Pflicht.



L'utilisation d'un casque de protection est obligatoire.

Het gebruik van een veiligheidshelm is verplicht.

The use of a hard hat is mandatory.

Das Tragen eines Sicherheitshelms ist Pflicht.

Liste d'outils / Gereedschappenlijst / Tools List / Werkzeugliste

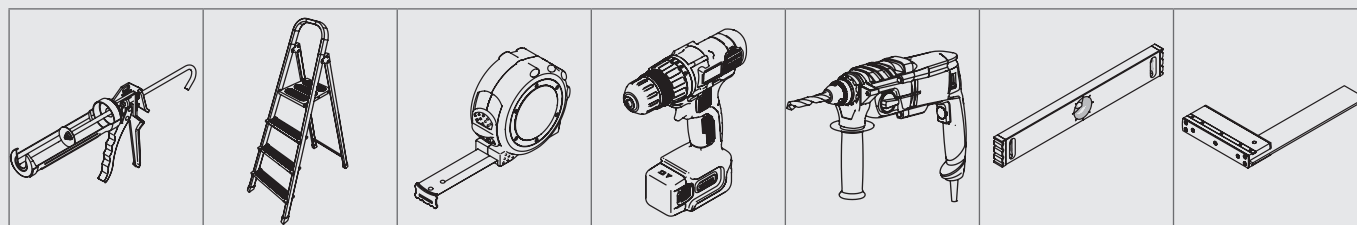

Liste des composants / Stukslijst / Partslist / Teileliste

A21 2x 	A24 1x 	AD24 1x 	B6 19x 	F6 8x 	HA6 4x 	FD18 1x
UD18 1x 	K6LD 1x 	KT18 1x 	K6R 1x 	K6S 6x 	DR 1x 	DL 1x
J24R 1x 	J21 2x 	J24 1x 	J21S 2x 	JDA24 1x 	JD24 1x 	Z24A 1x
Z21B 1x 	Z24C1 1x 	Z24C2 1x 	Z21D 1x 	Z21T 2x 	2721-1 1x 	2721-2 1x
2721-3 1x 	DA030 12x 	DA21 10x 	DA24 6x 	DAVL21 1x 	DAVR21 1x 	DI030 12x
DI21 10x 	DI24 6x 	DIVR21 1x 	DIVL21 1x 	X24A 1x 	X21B 1x 	X24C 1x
X21D 1x 	IG 2x 	IK 2x 	TP2724 3x 	GP2724 3x 	BF21 7x 	PP21 1x

option / optie / option / Option

Liste des composants / Stukslijst / Partslist / Teileliste

OS18 1x 	CP05 8x 	CP01 4x 	CP02 4x 	SD18 2x 200x 	SD18BL 30x 	SD16D 18x
BZ 12x 	SD25 2x 	SP 4x 	TOOL1 1x 	TOOL2 2x 	TOOL3 1x 	RK1 ● 1x RK2 ● RK3 ○
W1 1x 	W2 1x 	W3 1x 	W4 2x 	M24 2x 	M21 2x 	DK 1x

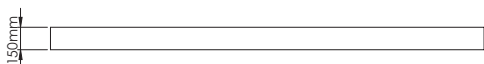
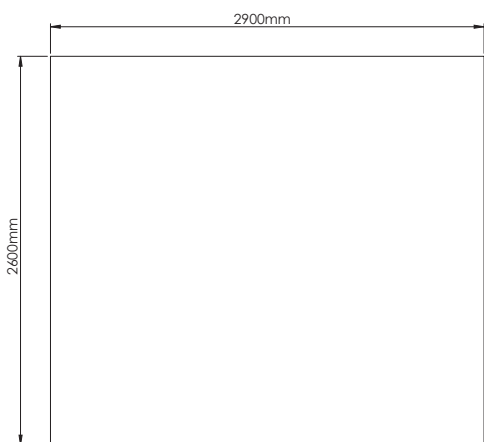

Fundament

- Le sol doit être plat et de niveau. Le sol doit être réalisé pour permettre une fixation adéquate de l'abris de jardin.
- De vloer moet vlak en waterpas zijn. De vloer moet gemaakt worden zodat de bevestiging van het tuinhuis wel mogelijk is.
- The floor must be flat and level. The floor must be made in such a way that it is possible to fix the garden house.
- Der Aufbauort muss eine flache, geschlossene und in Waage liegende Bodenplatte aufzeigen. Die Bodenplatte muss so beschaffen sein, das eine mechanische Befestigung von dem Eleganto erfolgen kann.

PS

- L'abris de jardin doit être centrée sur la dalle de béton.
- Het tuinhuis moet gecentreerd geplaatst worden op het fundament.
- The garden house must be centered on the foundation.
- Das Gartenhaus muss auf dem Fundament zentriert sein.

Tous les éléments / Alle elementen / All elements / Alle Elemente

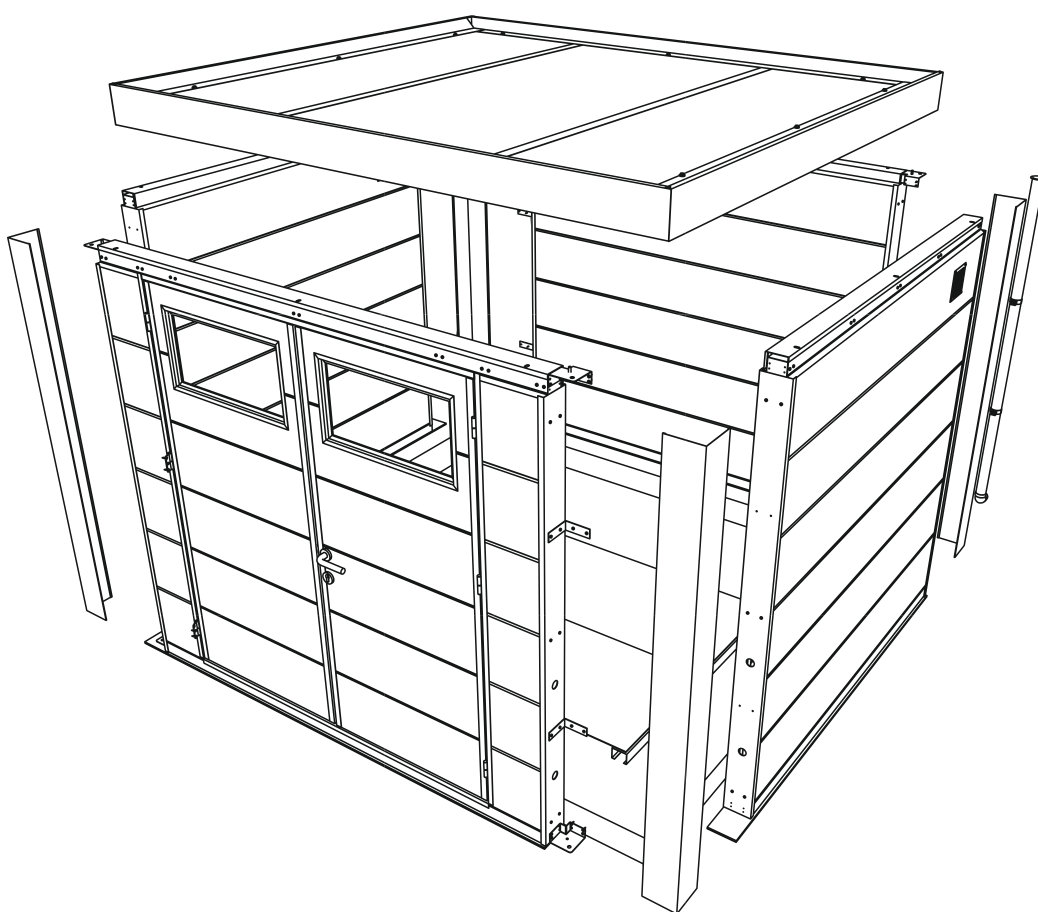

Composition / Compositie / Composition / Zusammensetzung

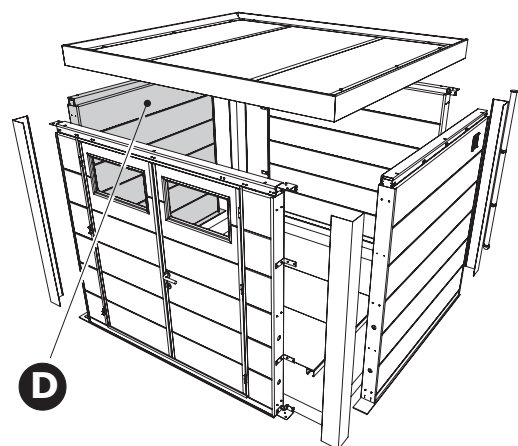
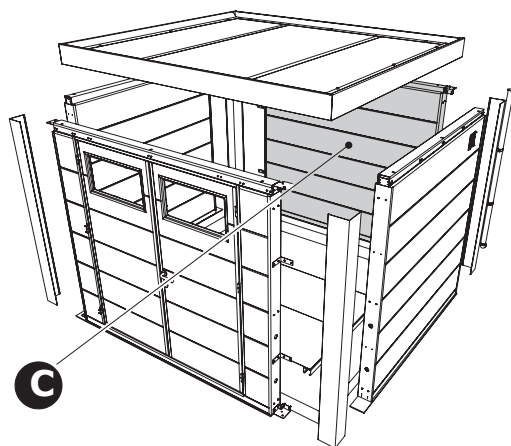
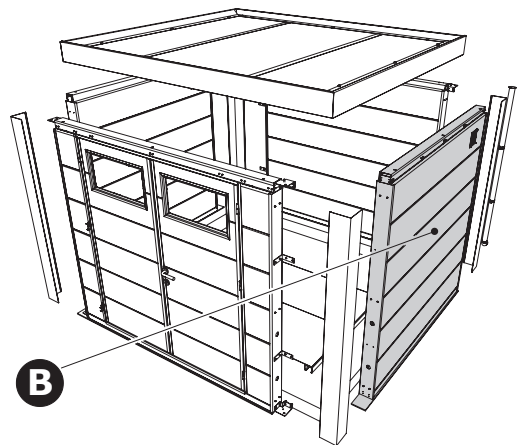
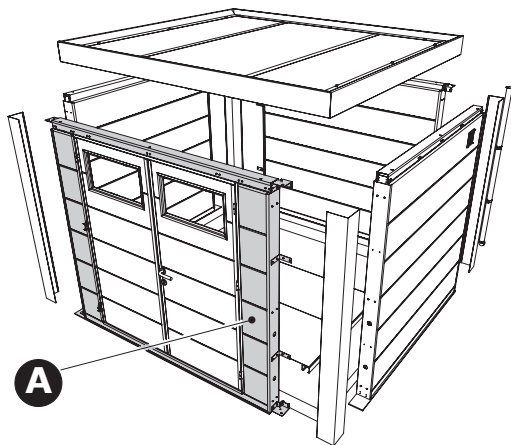
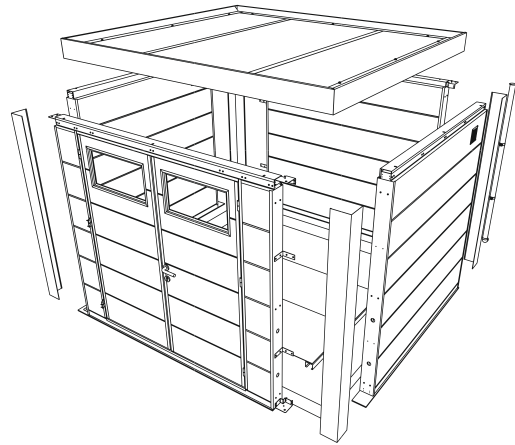
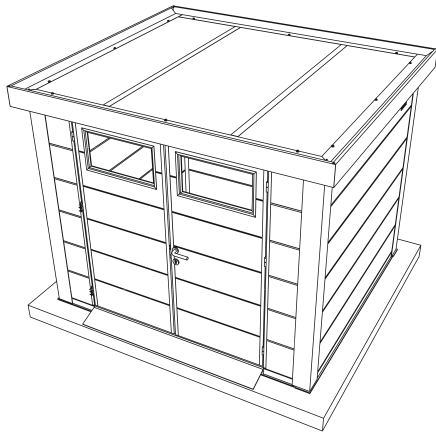

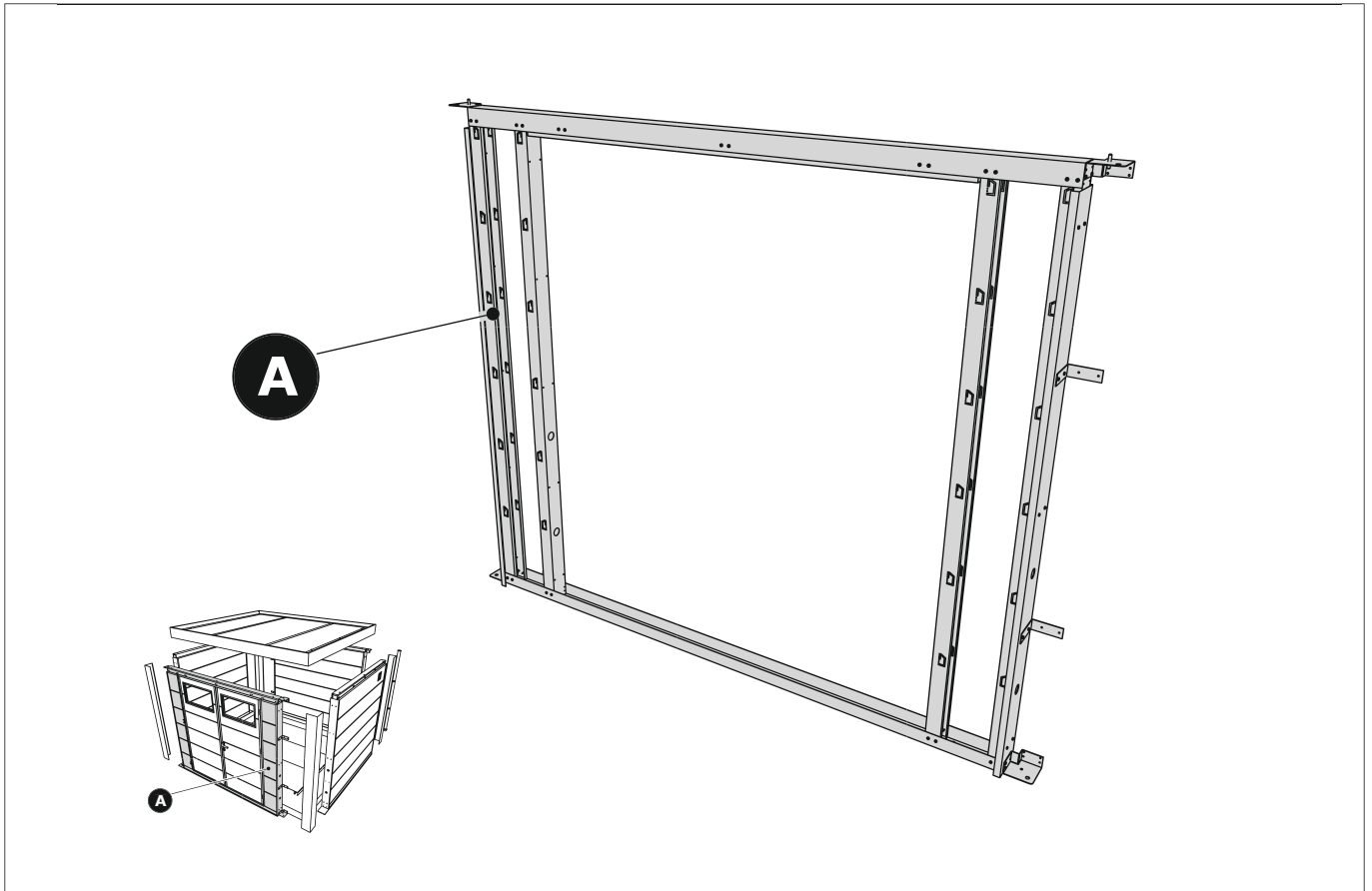

A Paroi / Wand / Wall / Wand

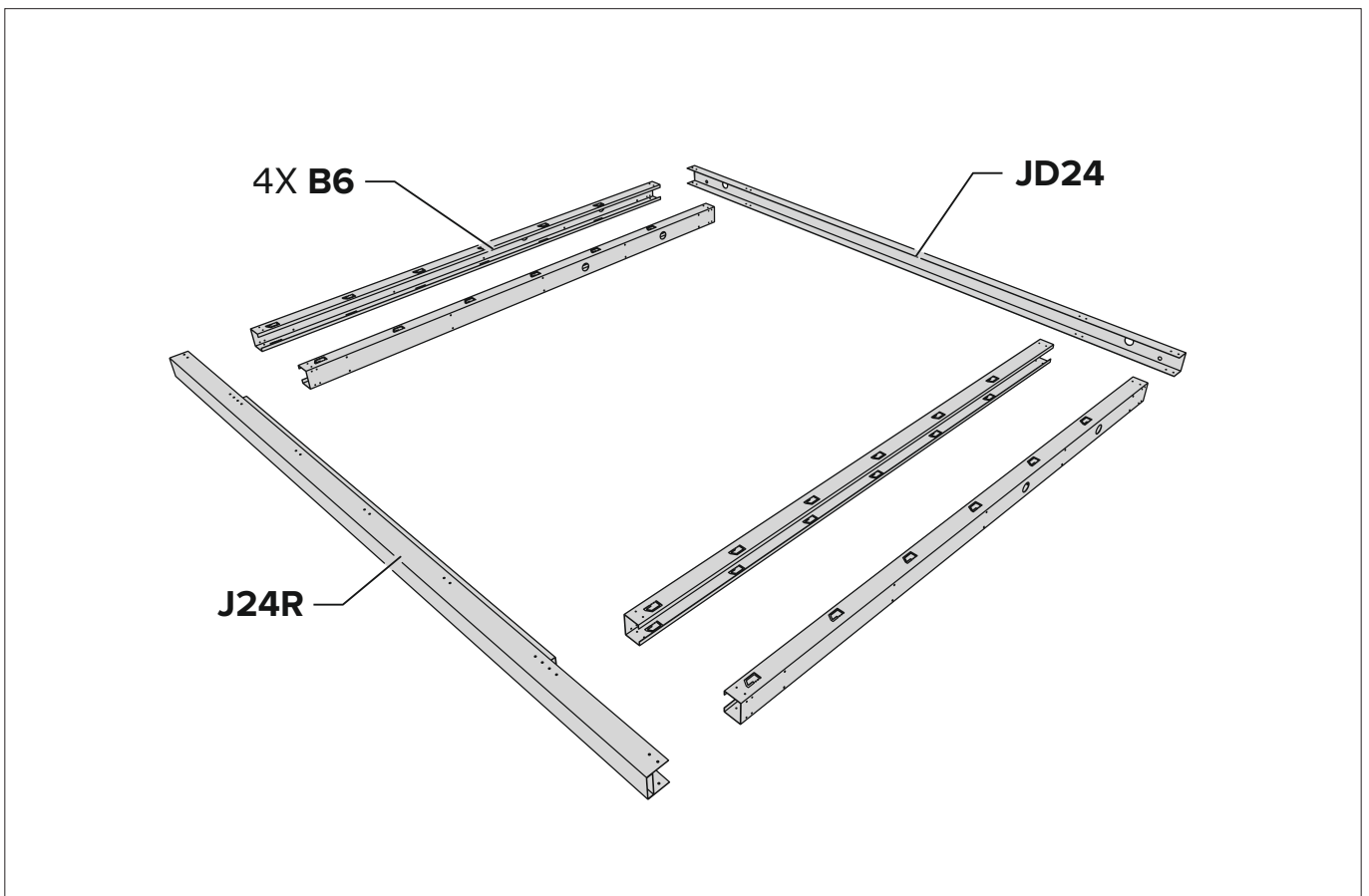

A Paroi / Wand / Wall / Wand

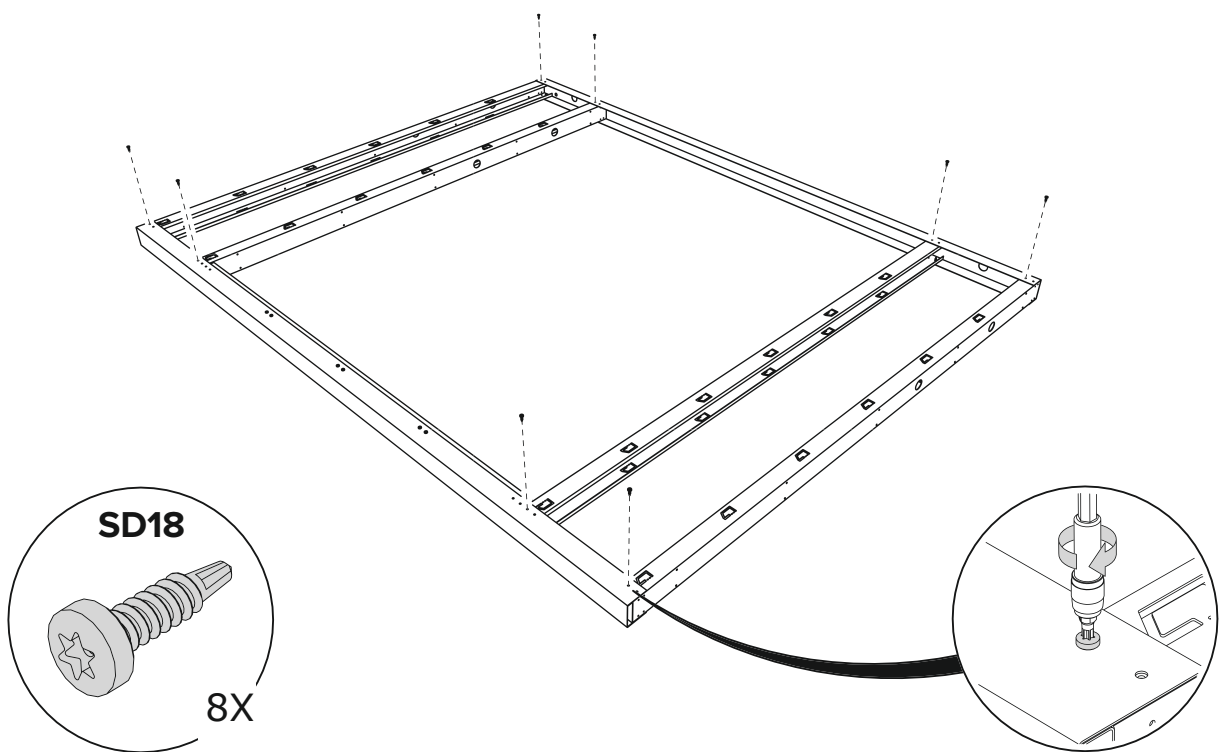

A Paroi / Wand / Wall / Wand

Tourner encadrement / Kader omdraaien / Turn Frame / Rahmen umdrehen

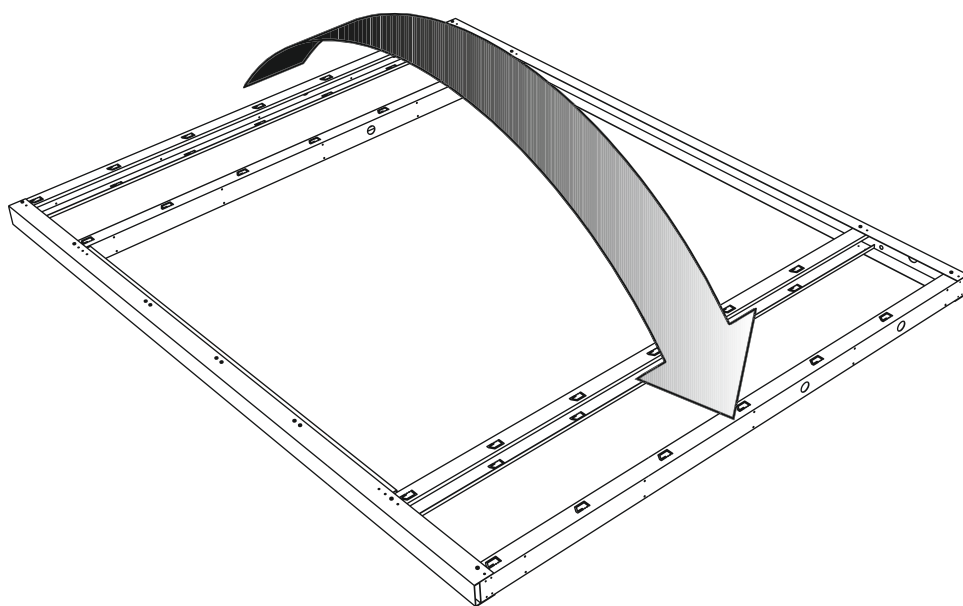

A Paroi / Wand / Wall / Wand

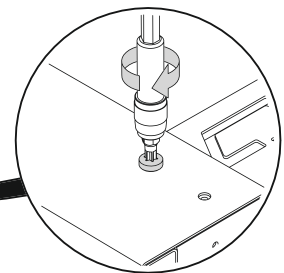
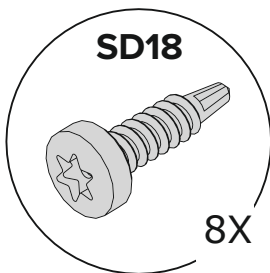
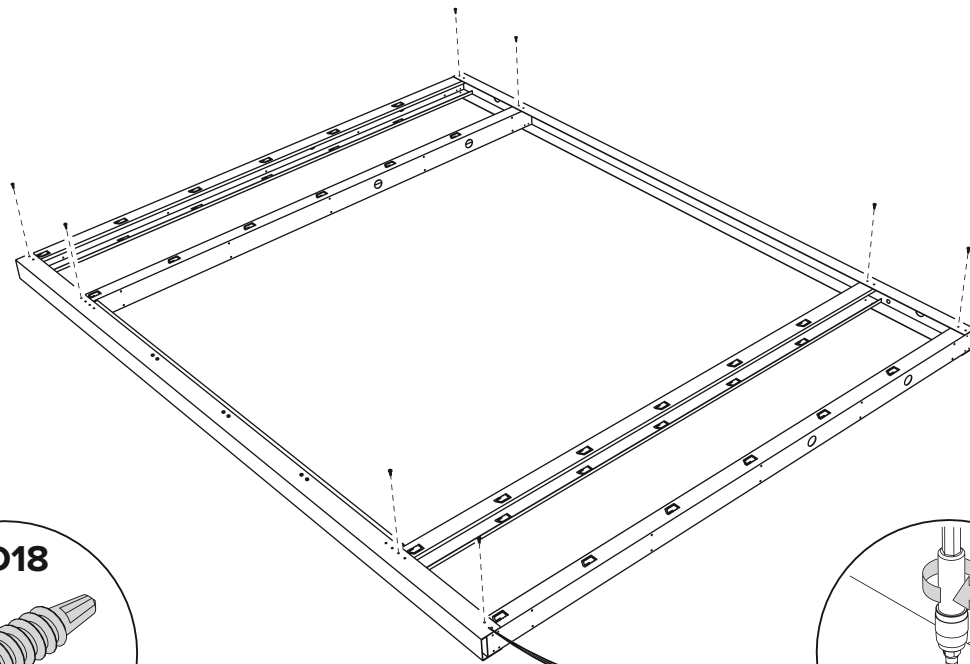

A Paroi / Wand / Wall / Wand

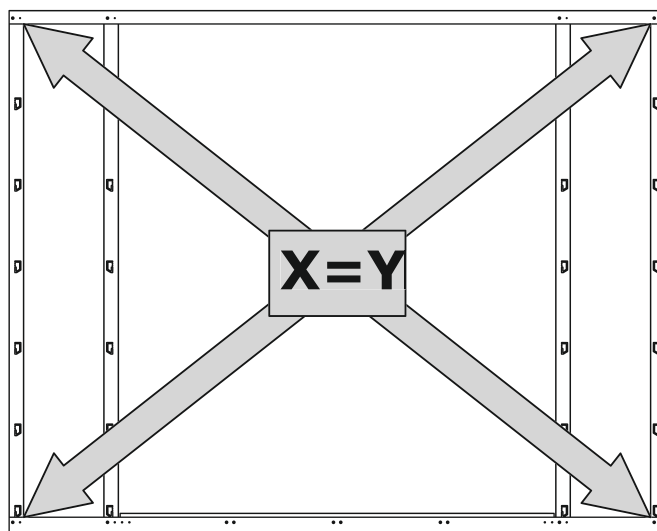
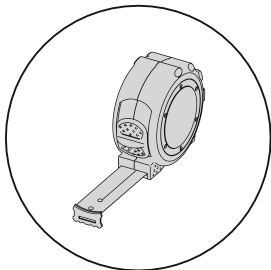

A Paroi / Wand / Wall / Wand

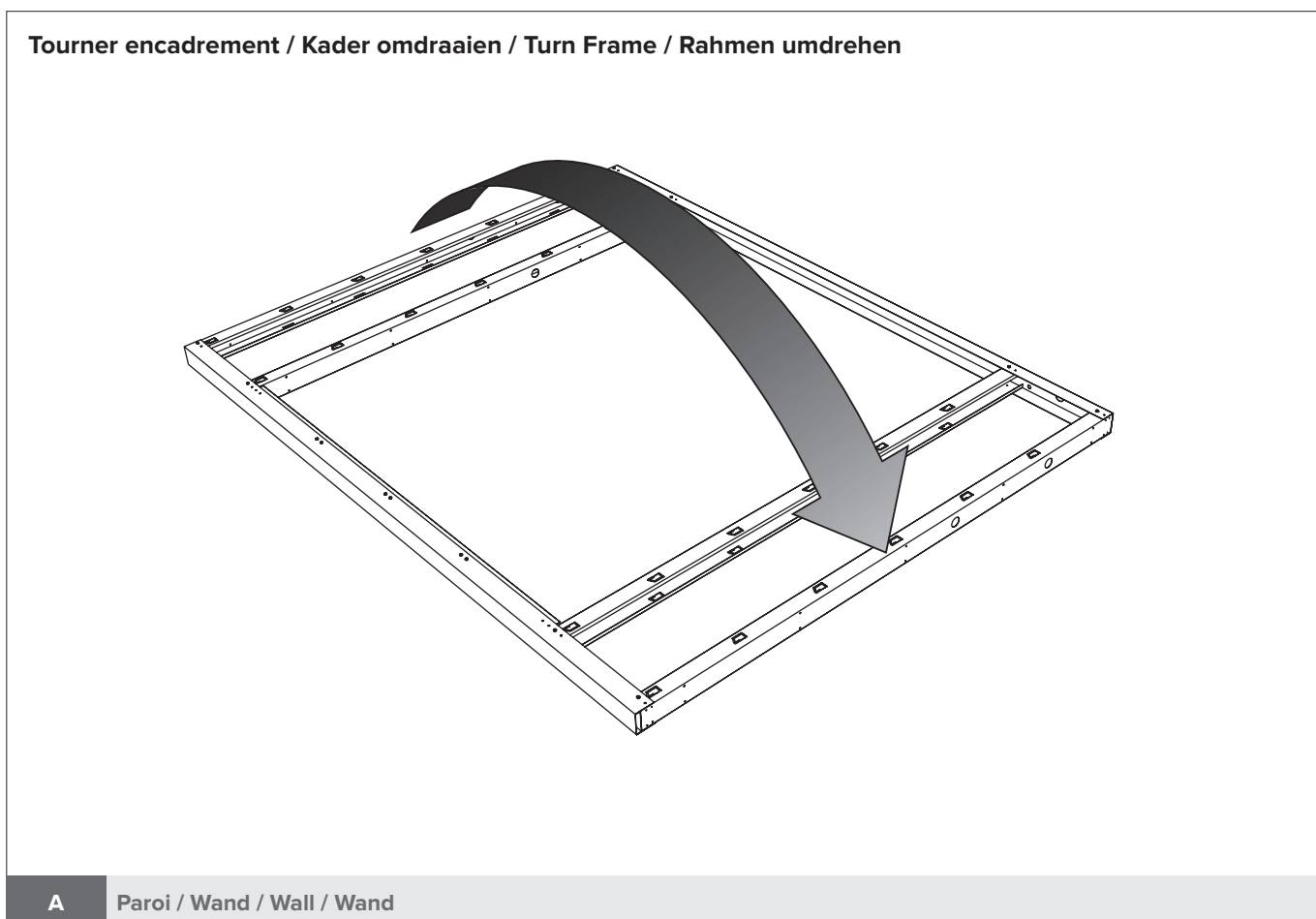
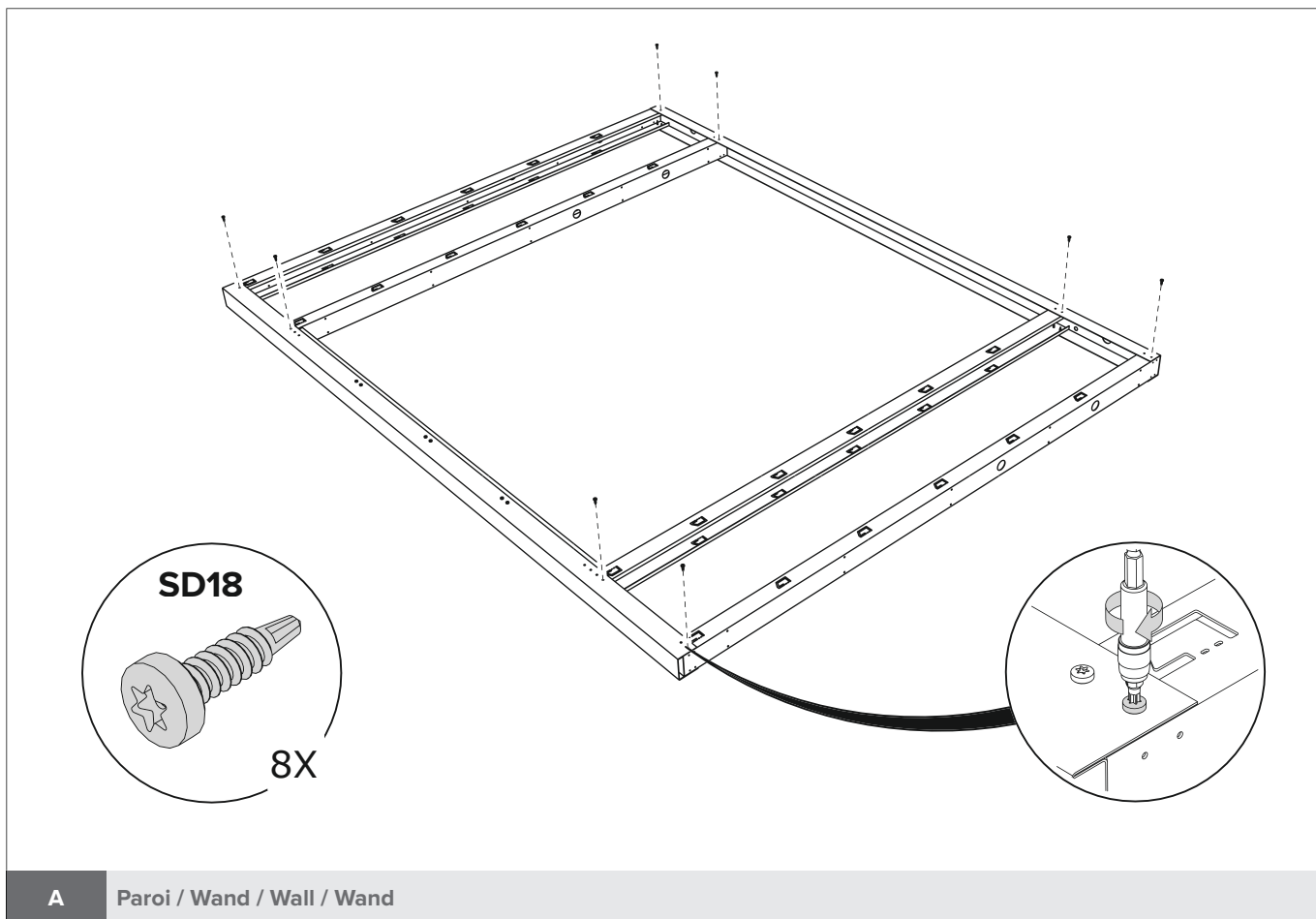

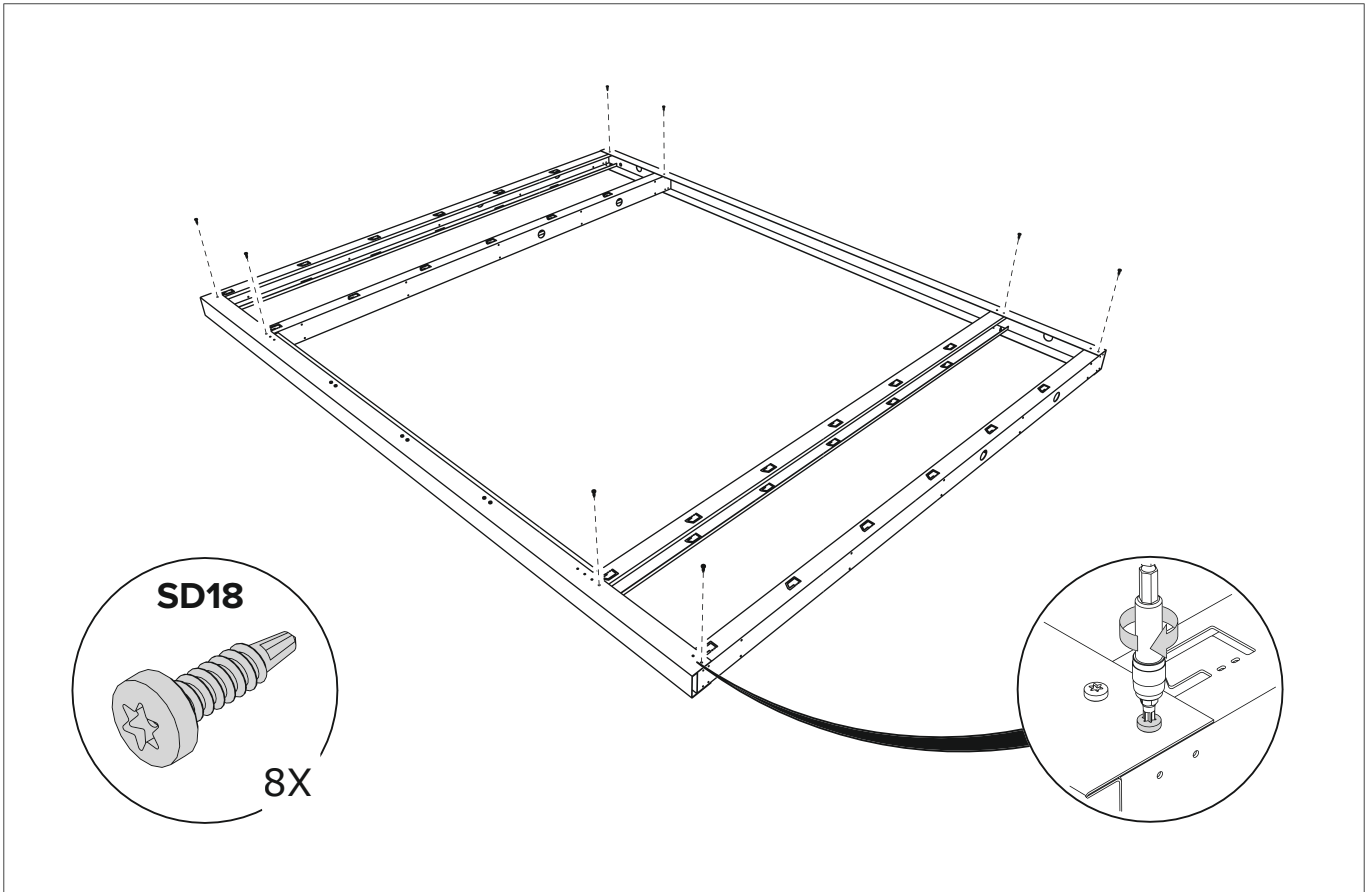

A Paroi / Wand / Wall / Wand

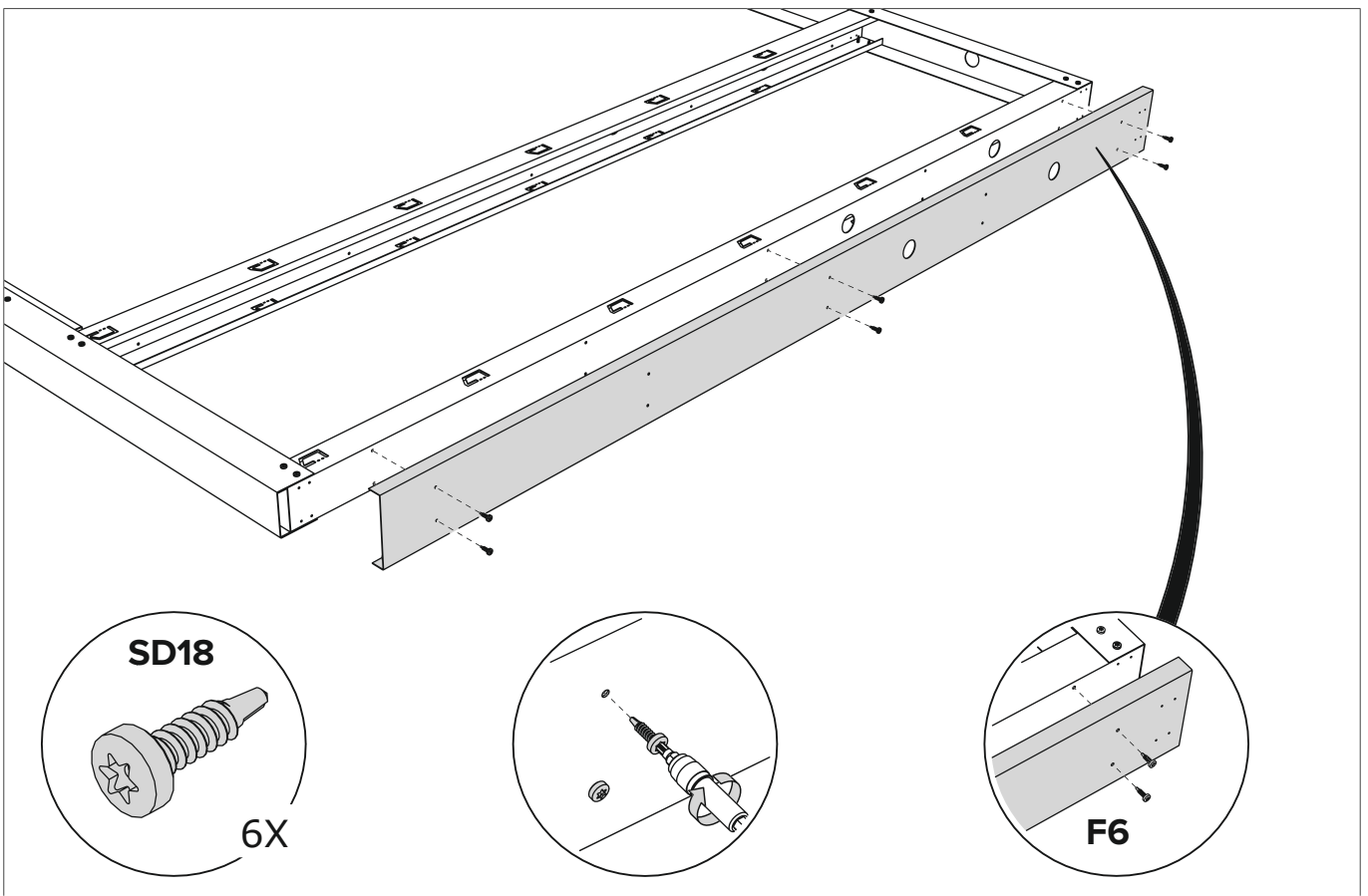

A Paroi / Wand / Wall / Wand

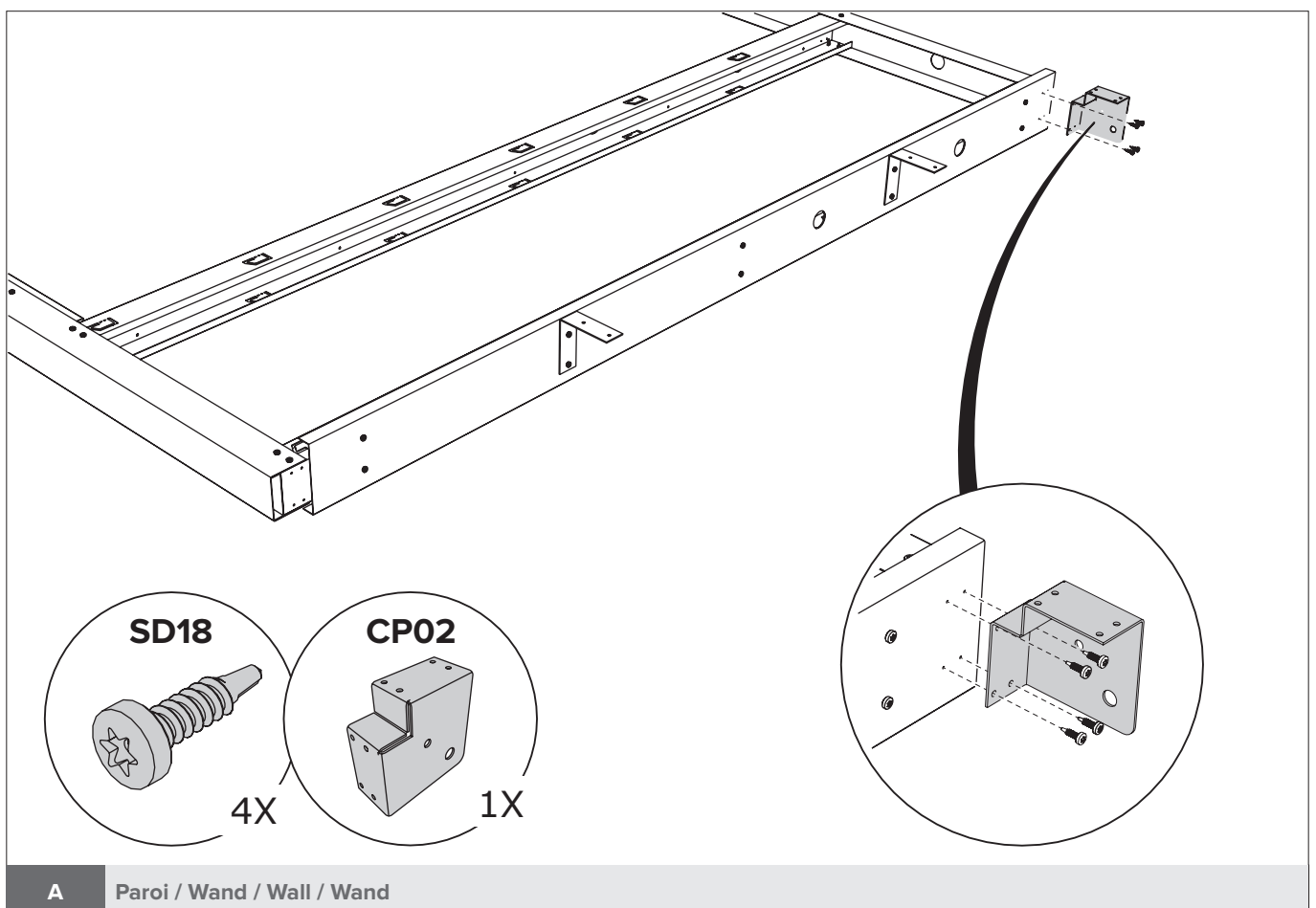
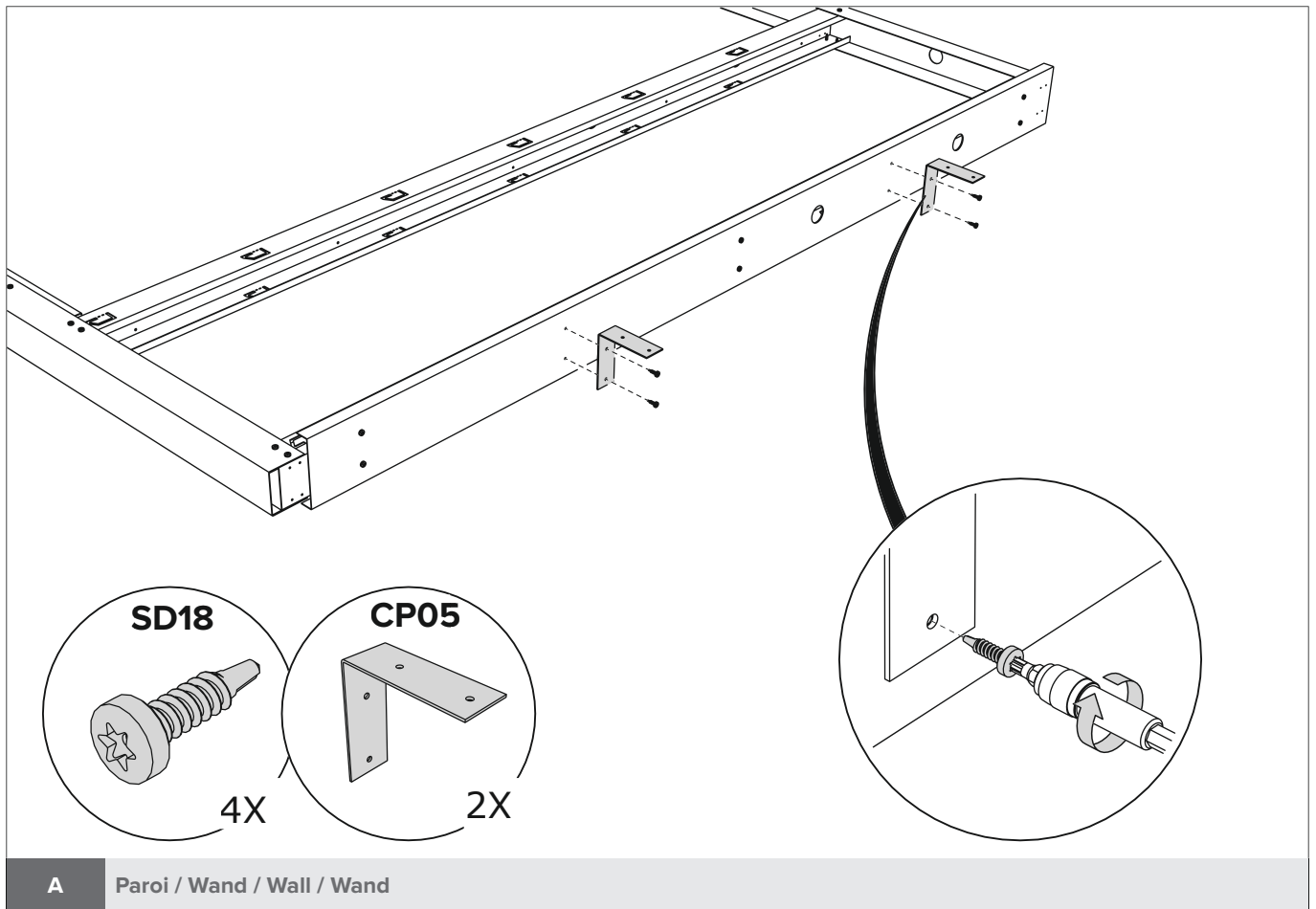

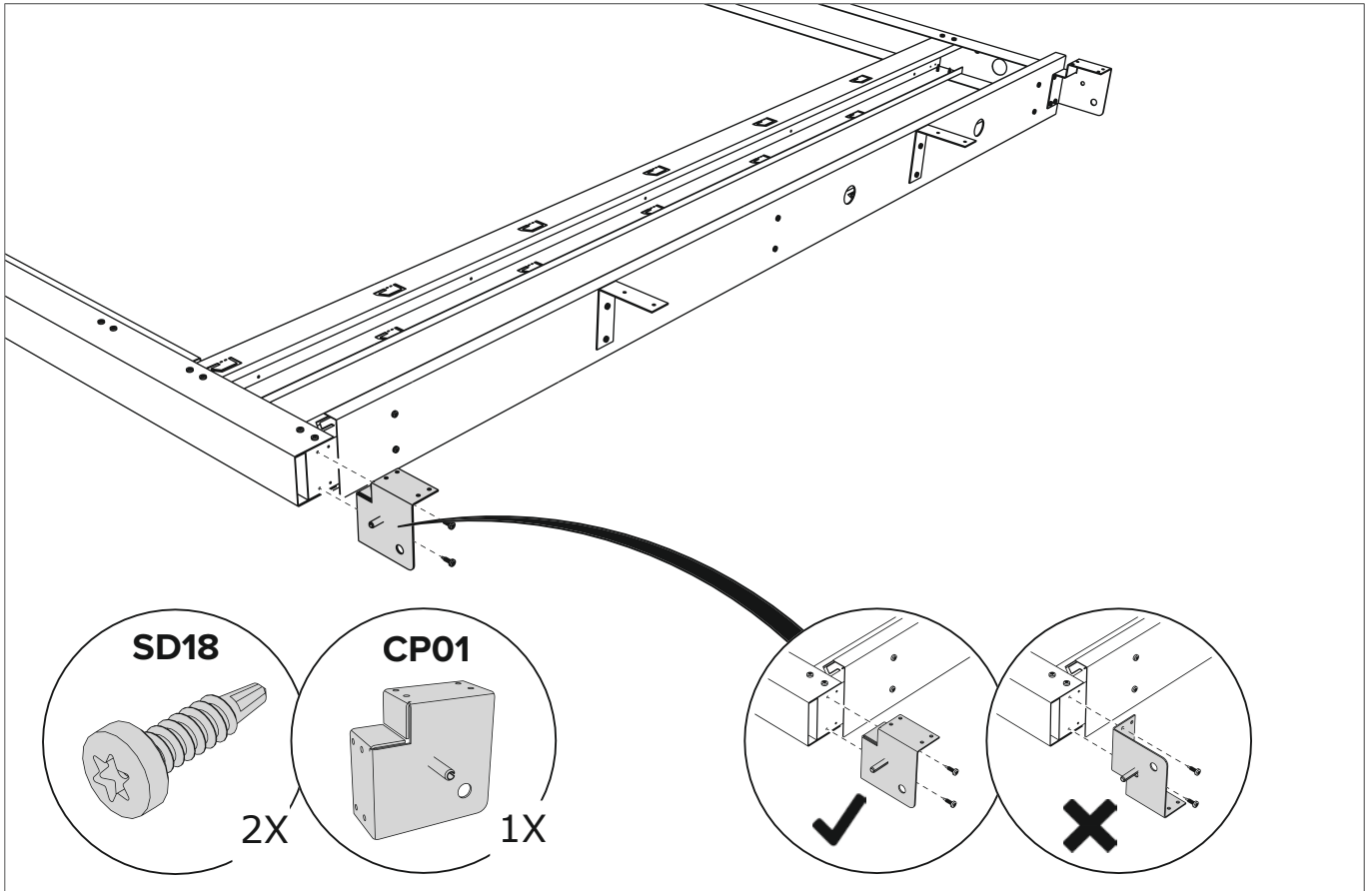

A Paroi / Wand / Wall / Wand

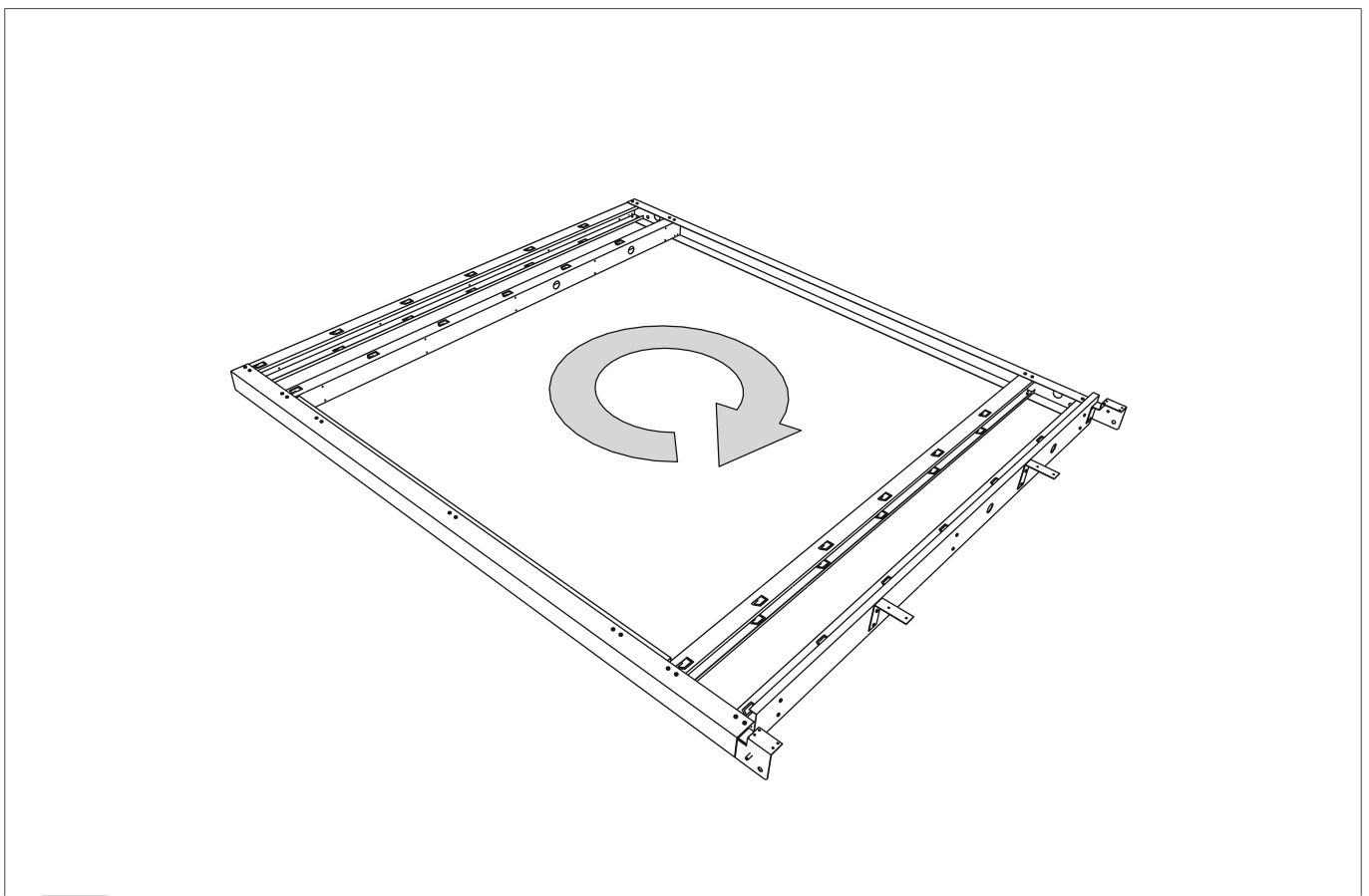

A Paroi / Wand / Wall / Wand

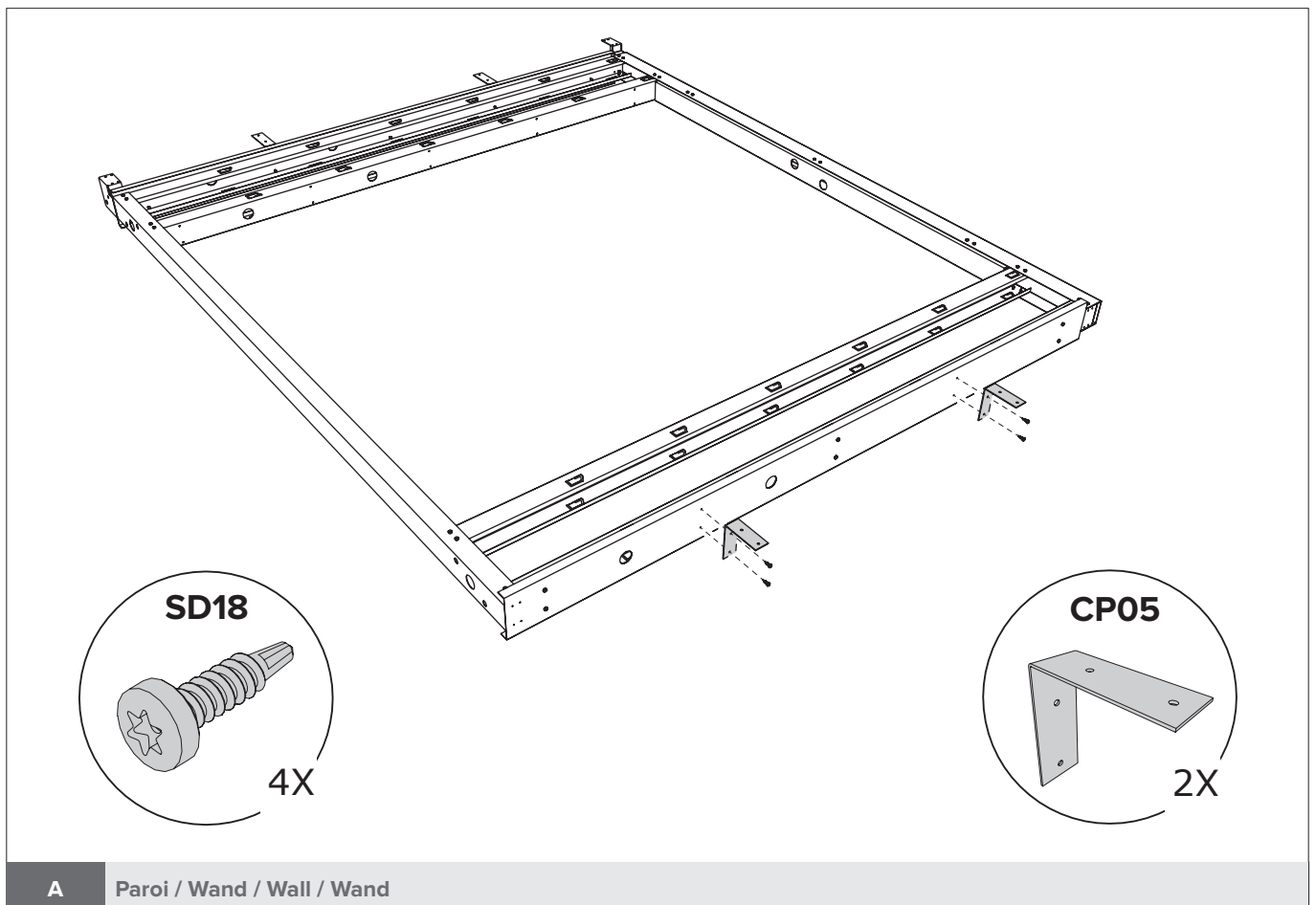
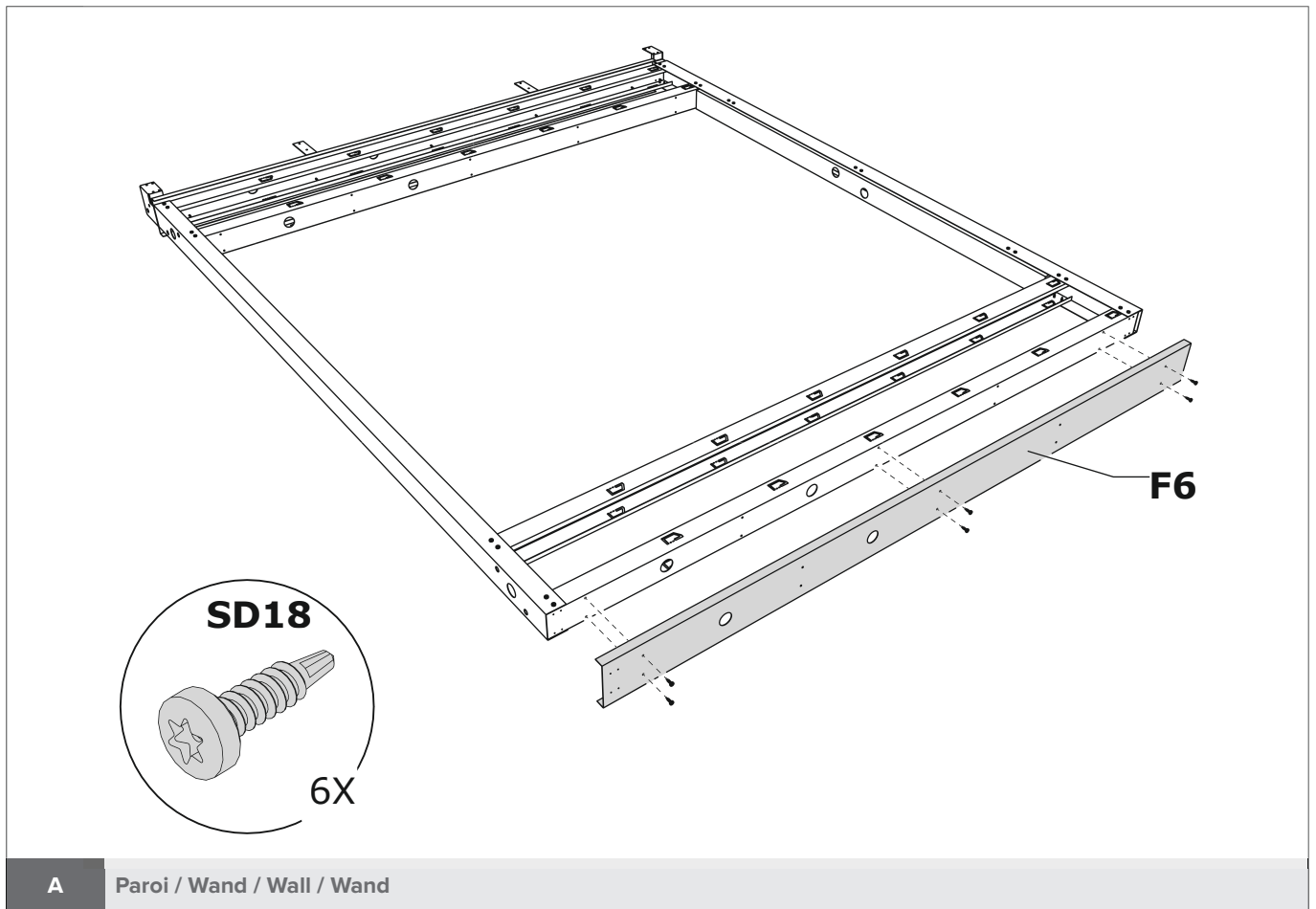

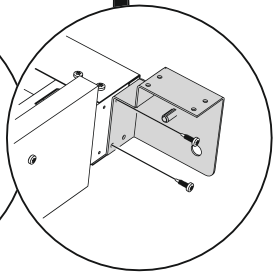
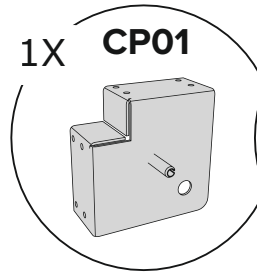
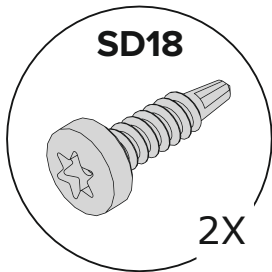
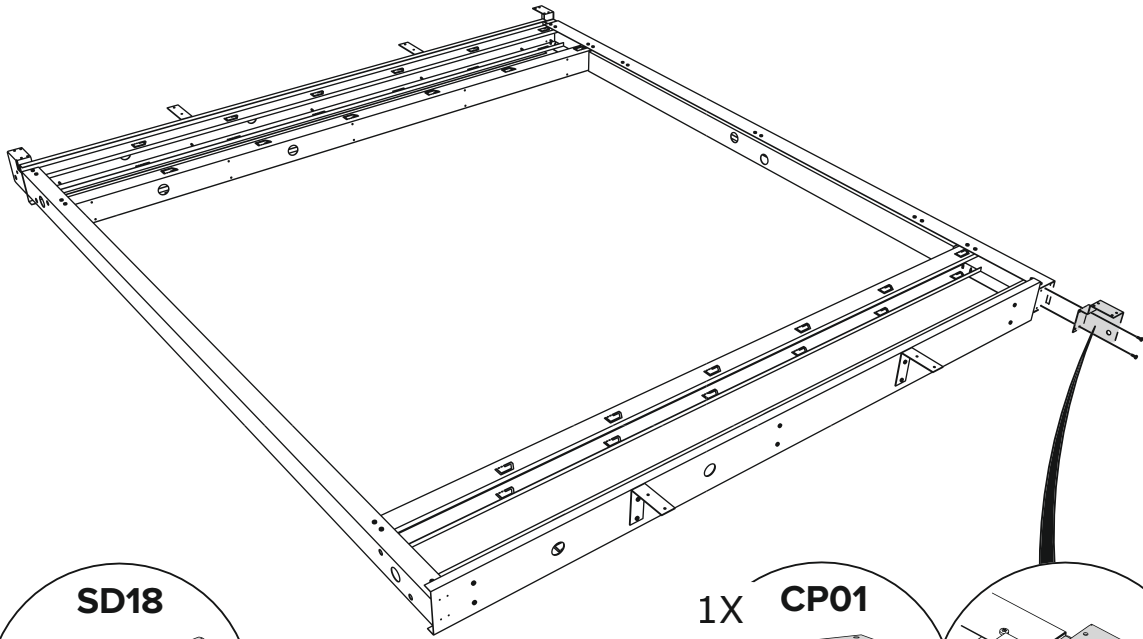

A Paroi / Wand / Wall / Wand

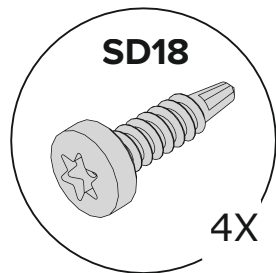
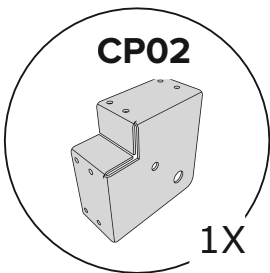
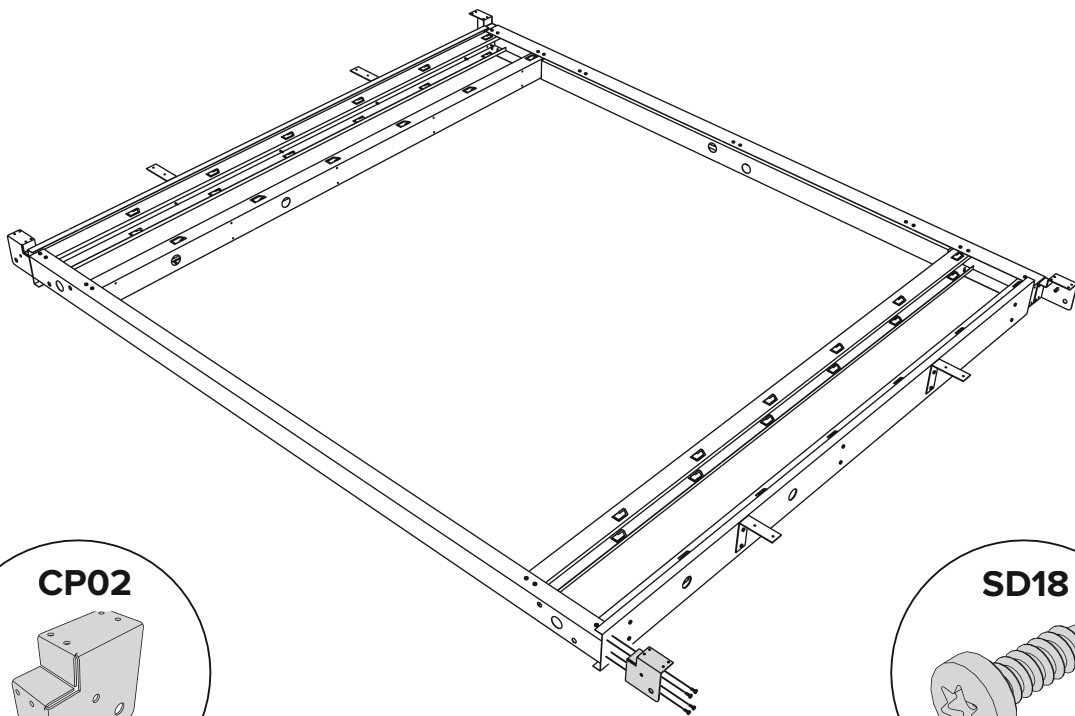

A Paroi / Wand / Wall / Wand

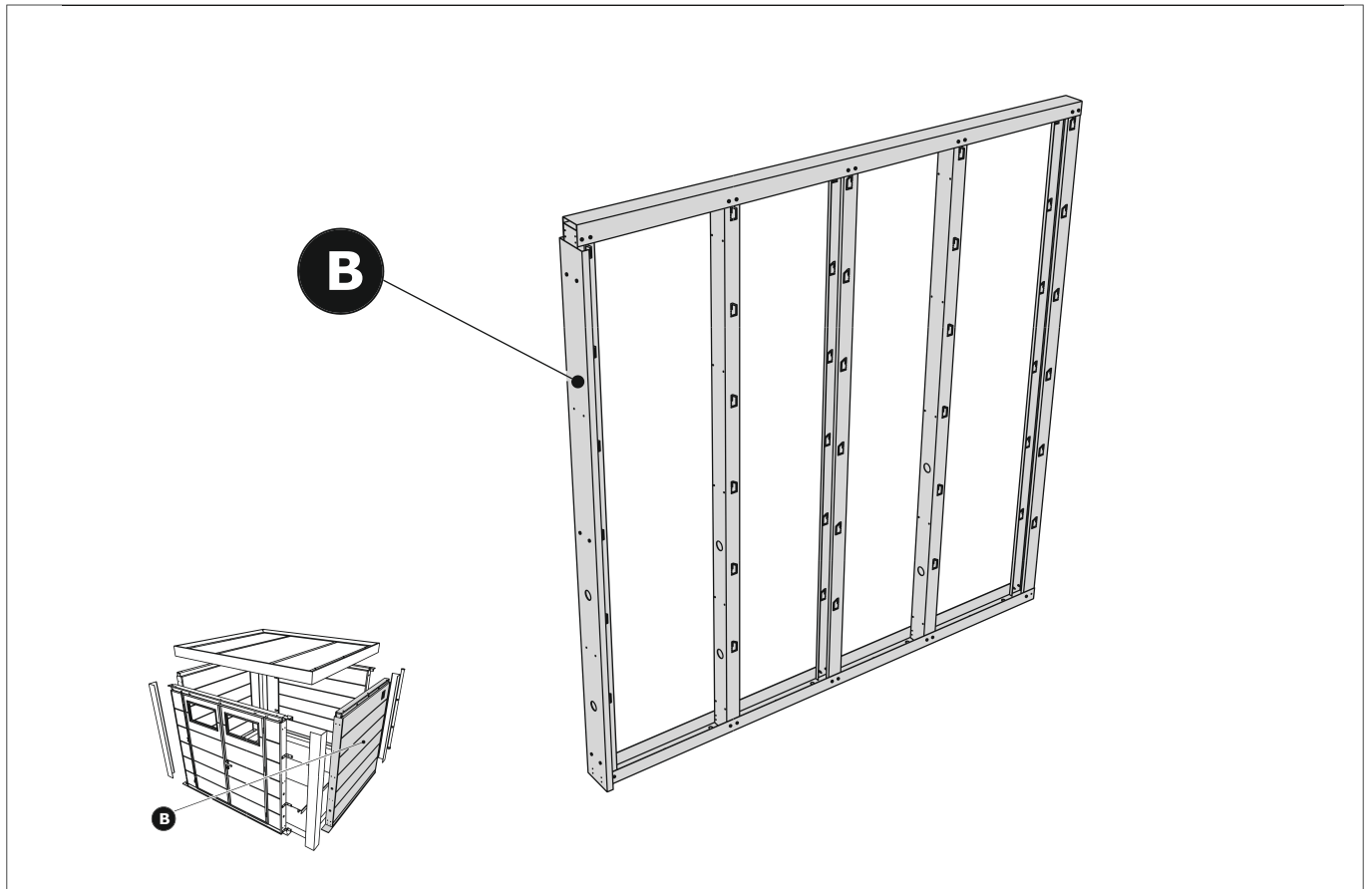

B Paroi / Wand / Wall / Wand

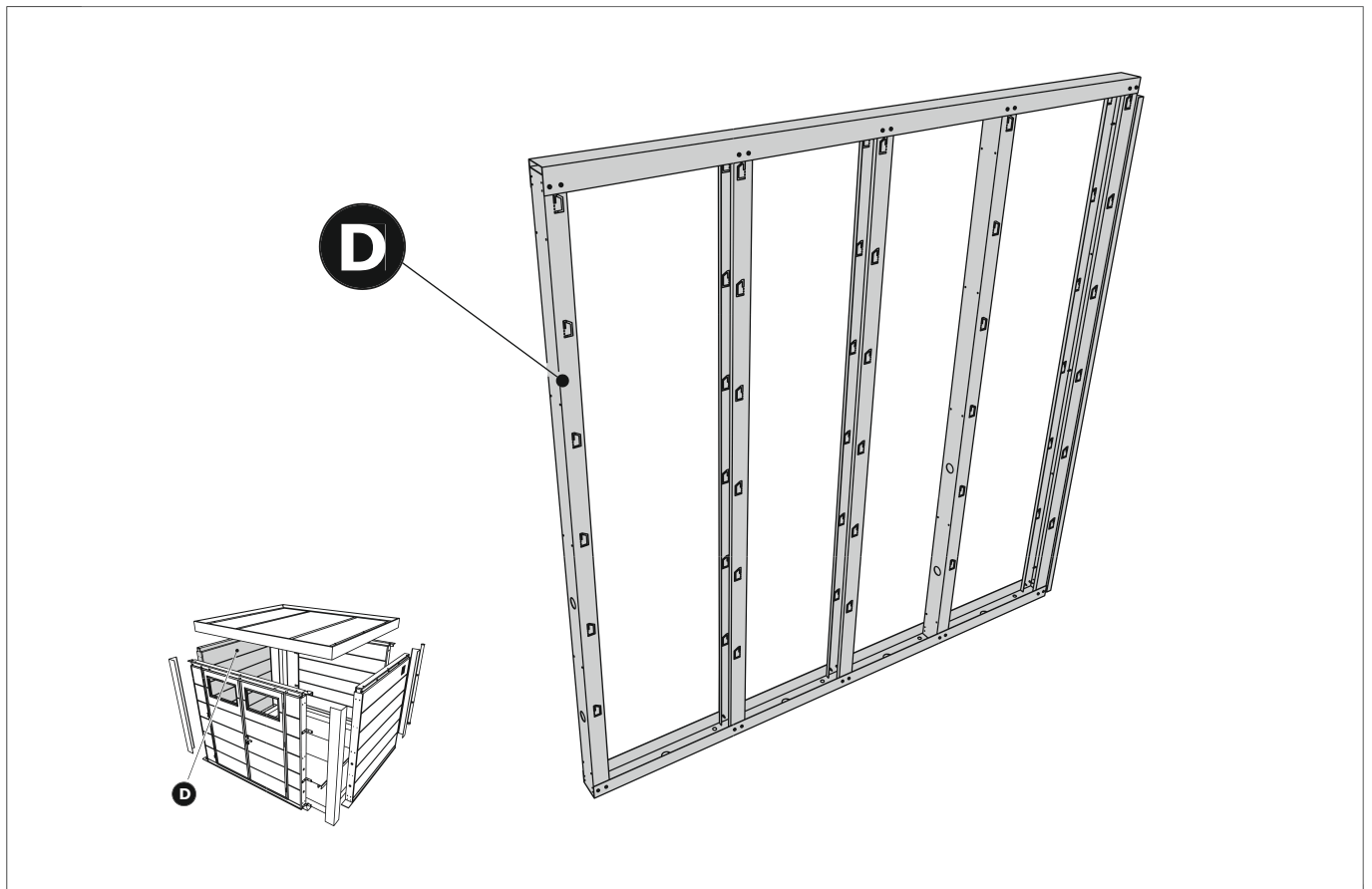

D Paroi / Wand / Wall / Wand

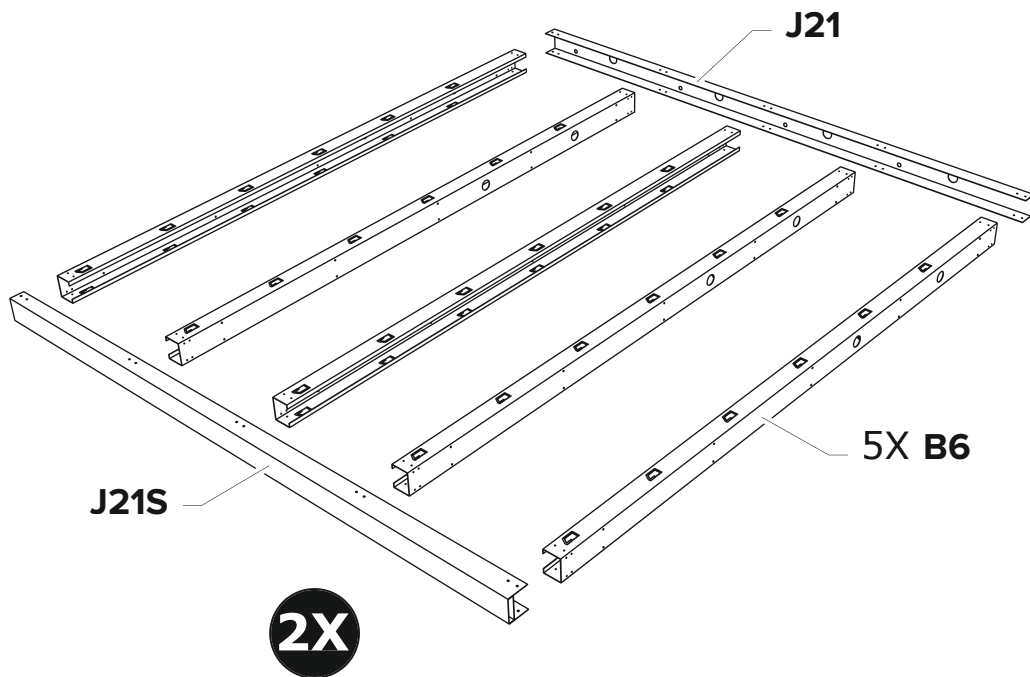

B / D Paroi / Wand / Wall / Wand

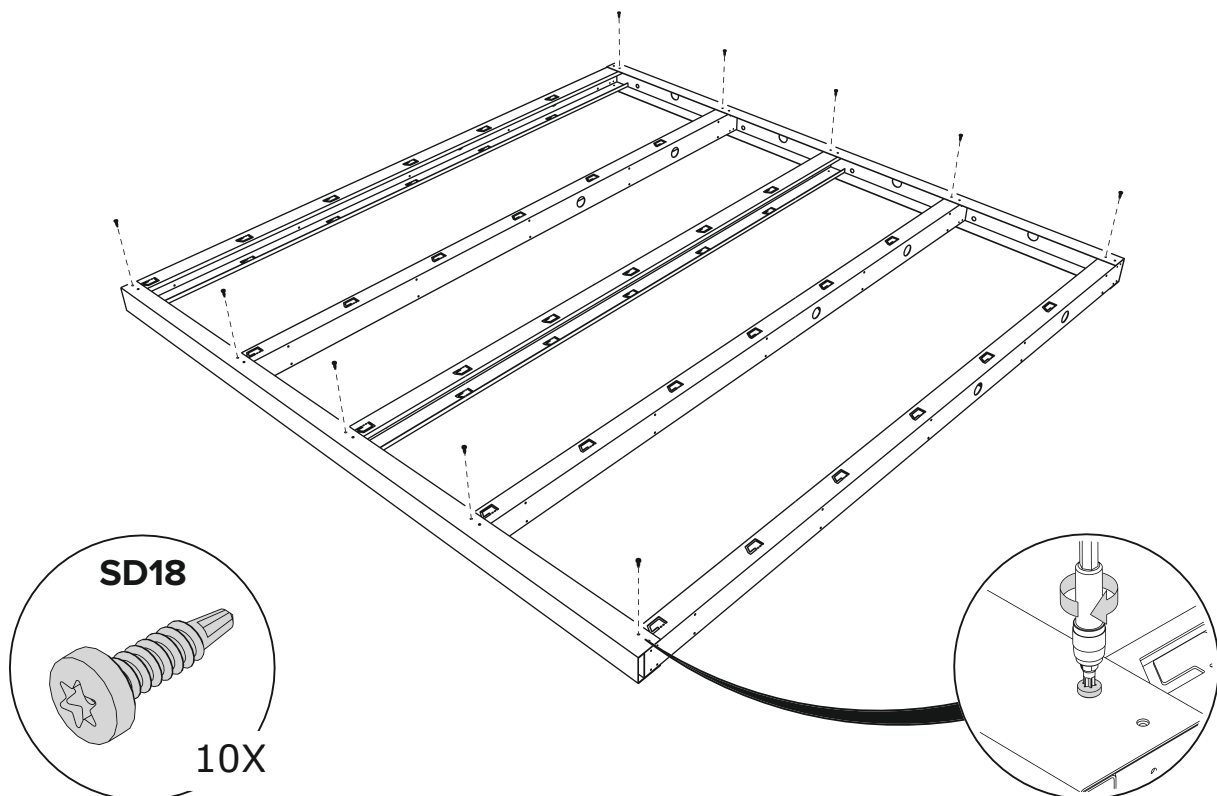

B / D Paroi / Wand / Wall / Wand

Tourner encadrement / Kader omdraaien / Turn Frame / Rahmen umdrehen

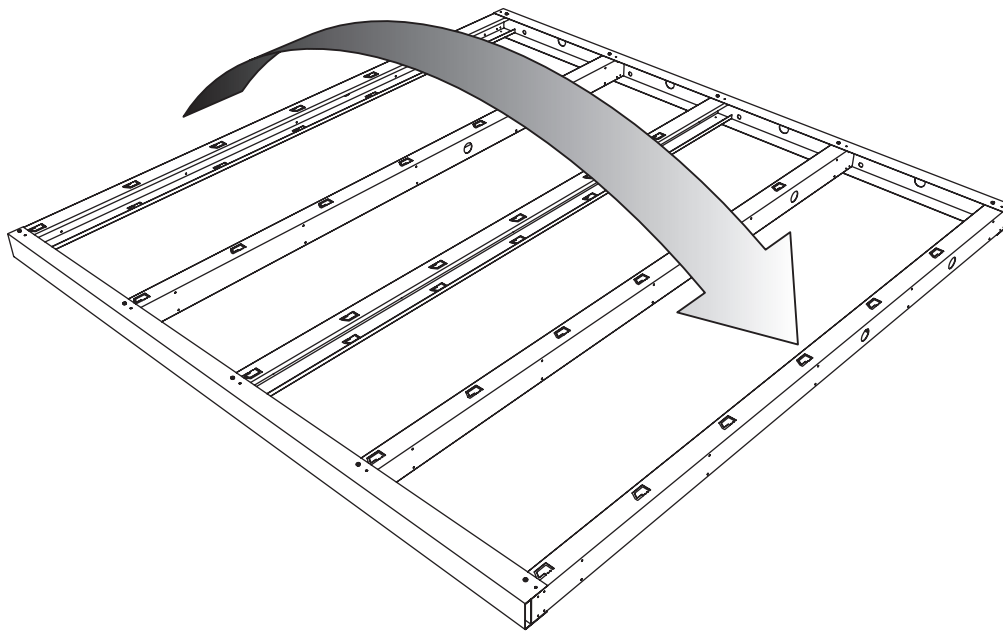

B / D Paroi / Wand / Wall / Wand

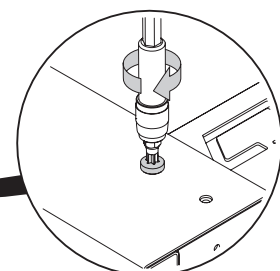
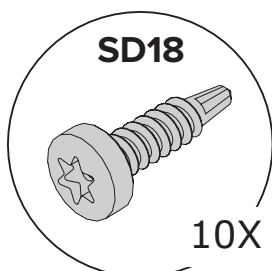
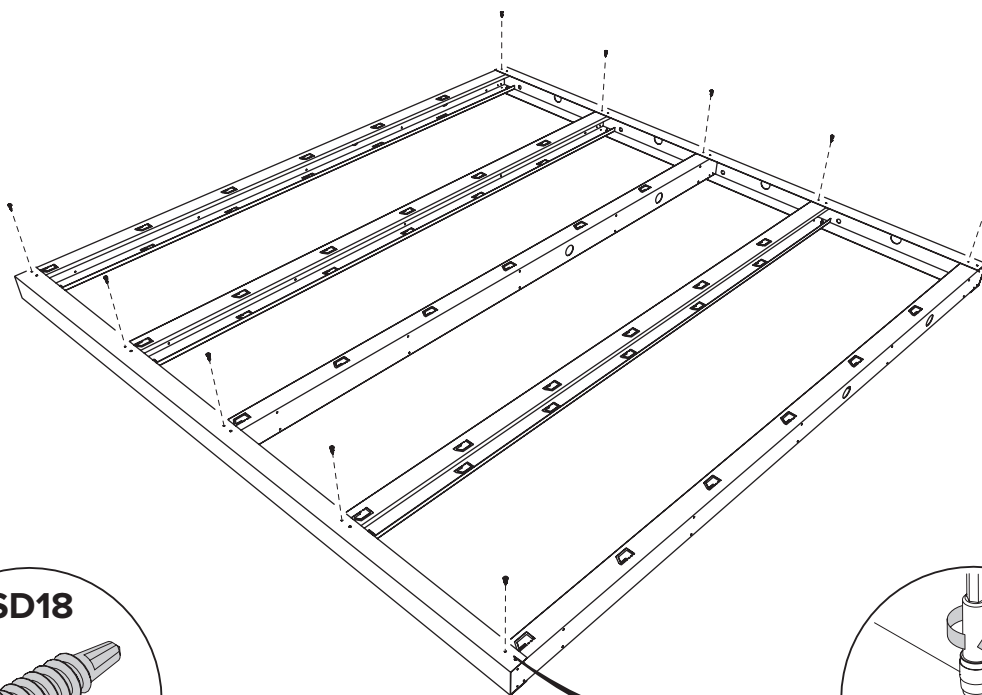

B / D Paroi / Wand / Wall / Wand

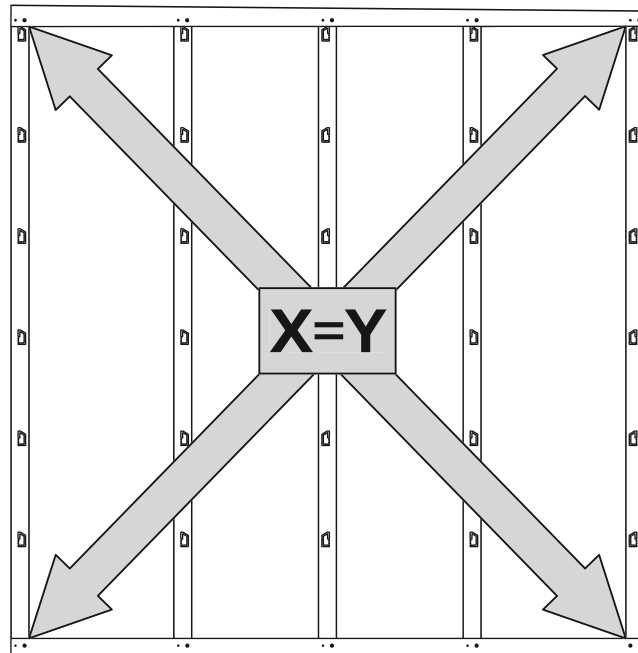
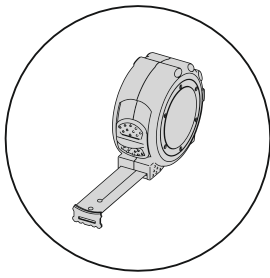

B / D Paroi / Wand / Wall / Wand

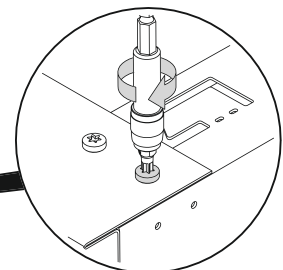
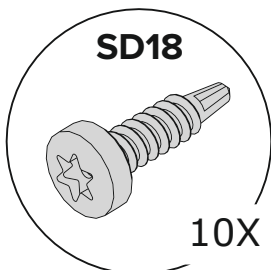
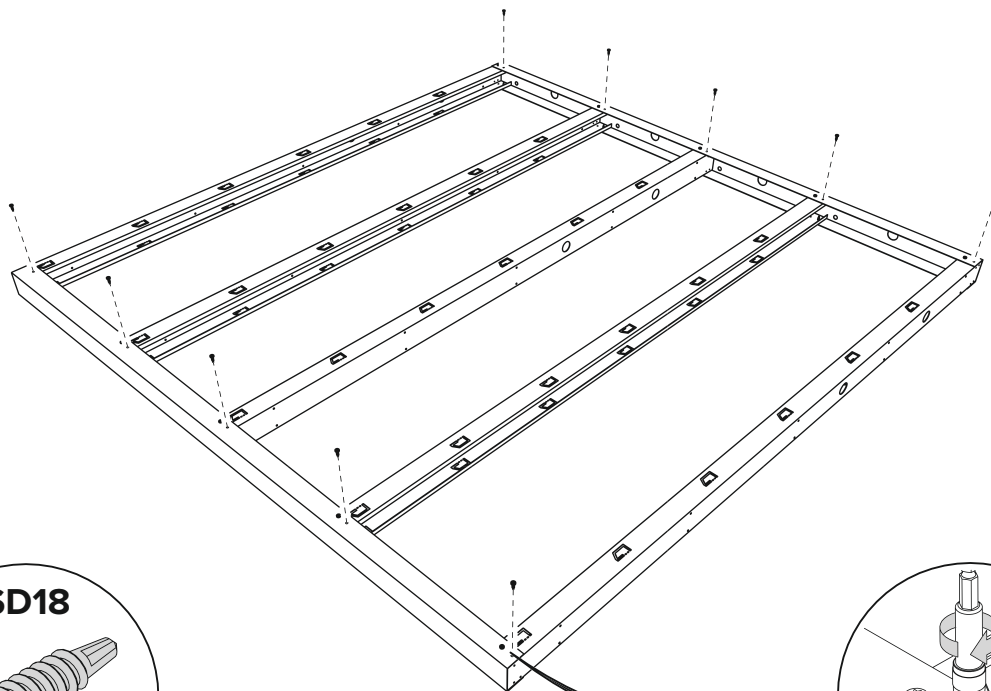

B / D Paroi / Wand / Wall / Wand

Tourner encadrement / Kader omdraaien / Turn Frame / Rahmen umdrehen

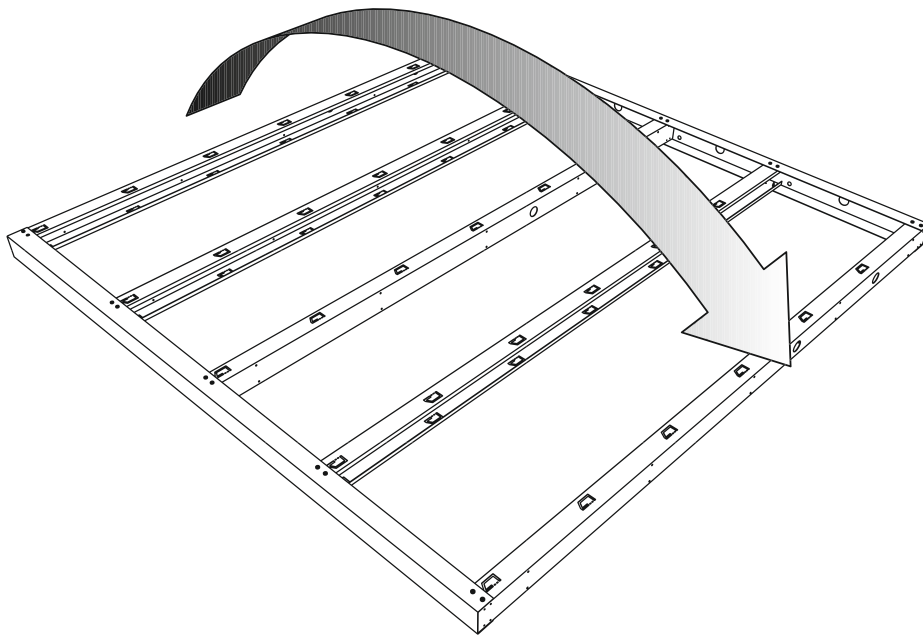

B / D Paroi / Wand / Wall / Wand

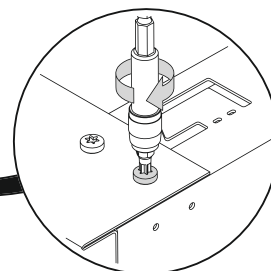
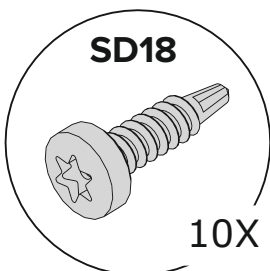
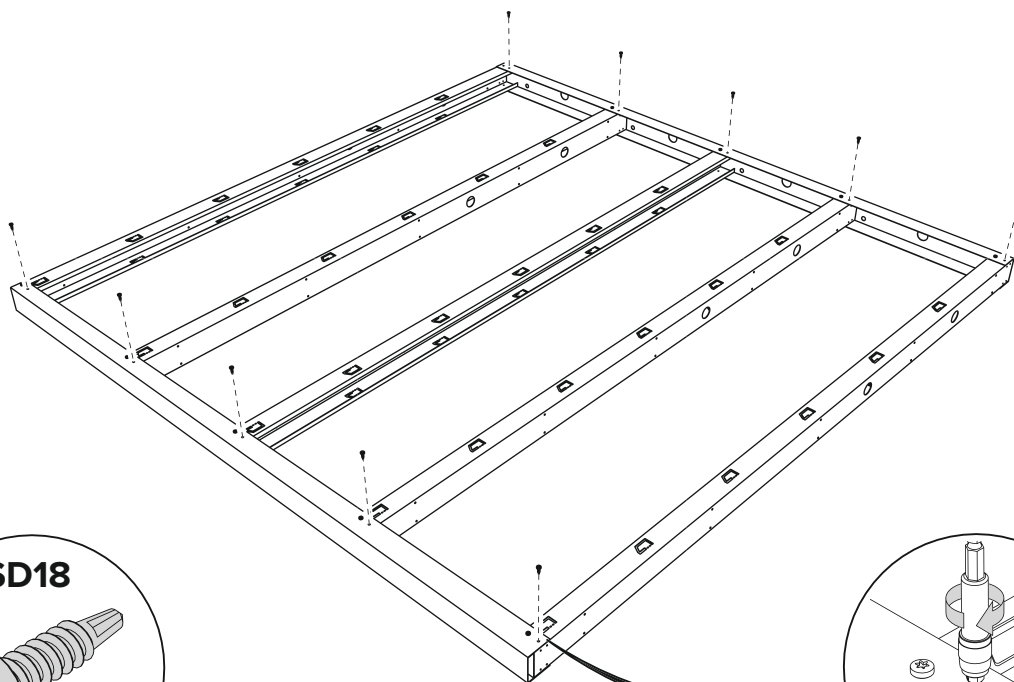

B / D Paroi / Wand / Wall / Wand

B

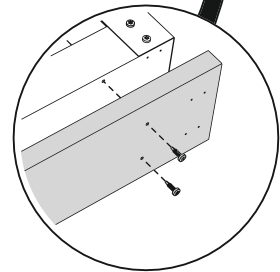
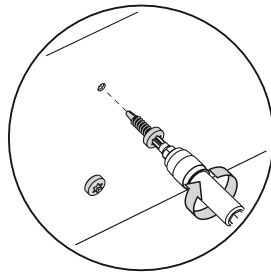
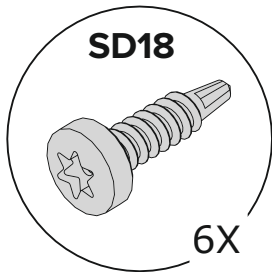
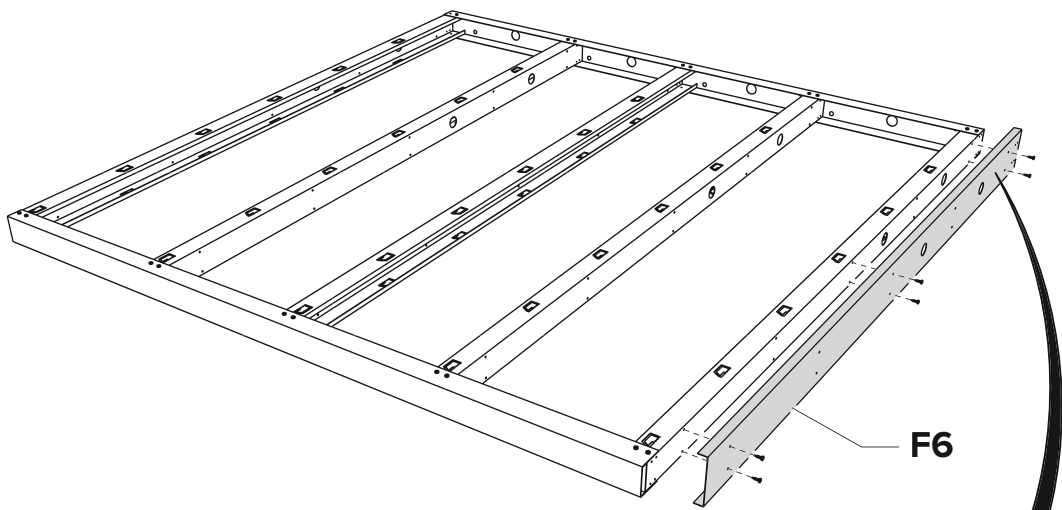

B Paroi / Wand / Wall / Wand

D

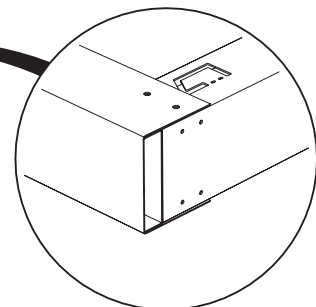
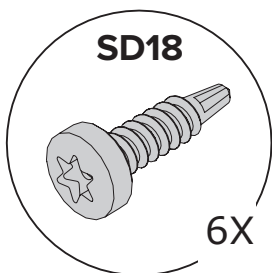
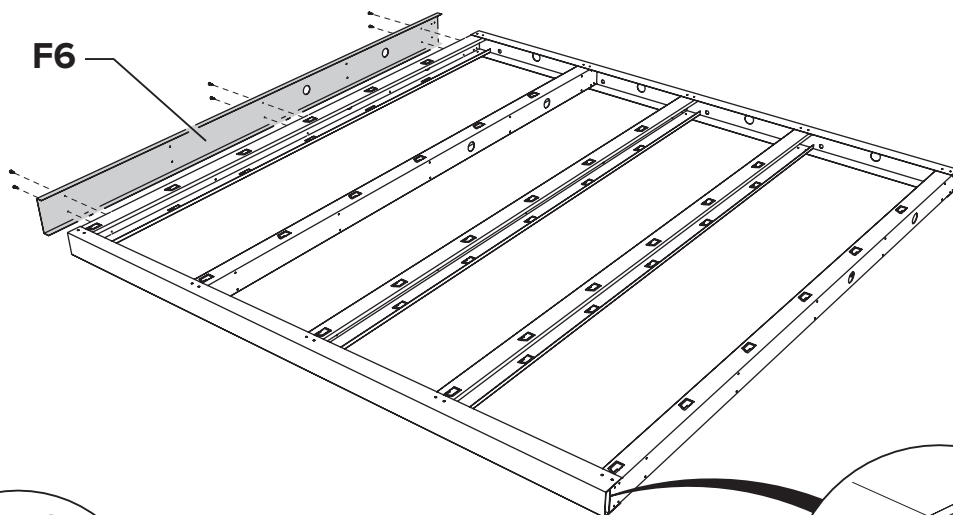

D Paroi / Wand / Wall / Wand

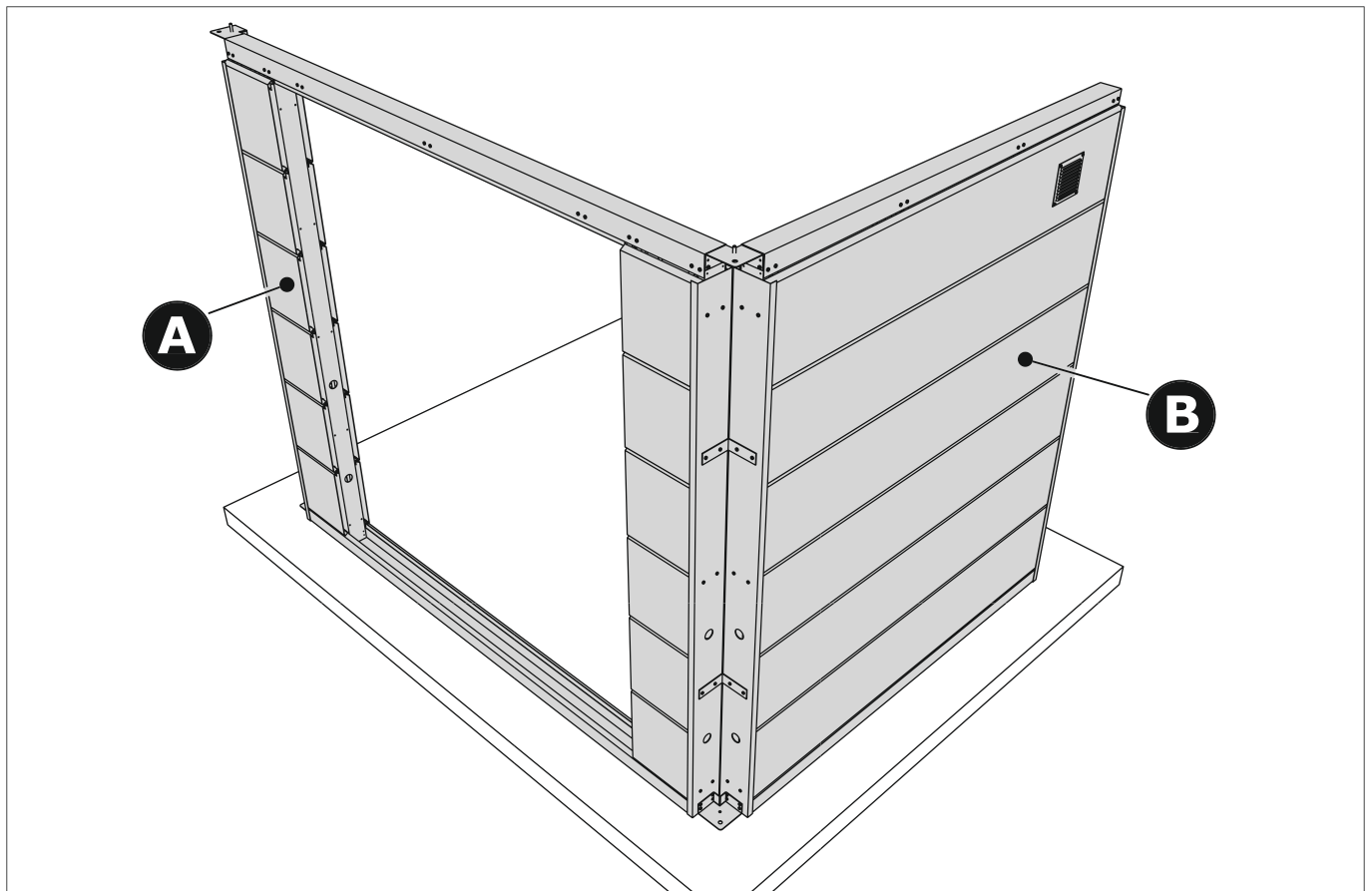

A + B Paroi / Wand / Wall / Wand

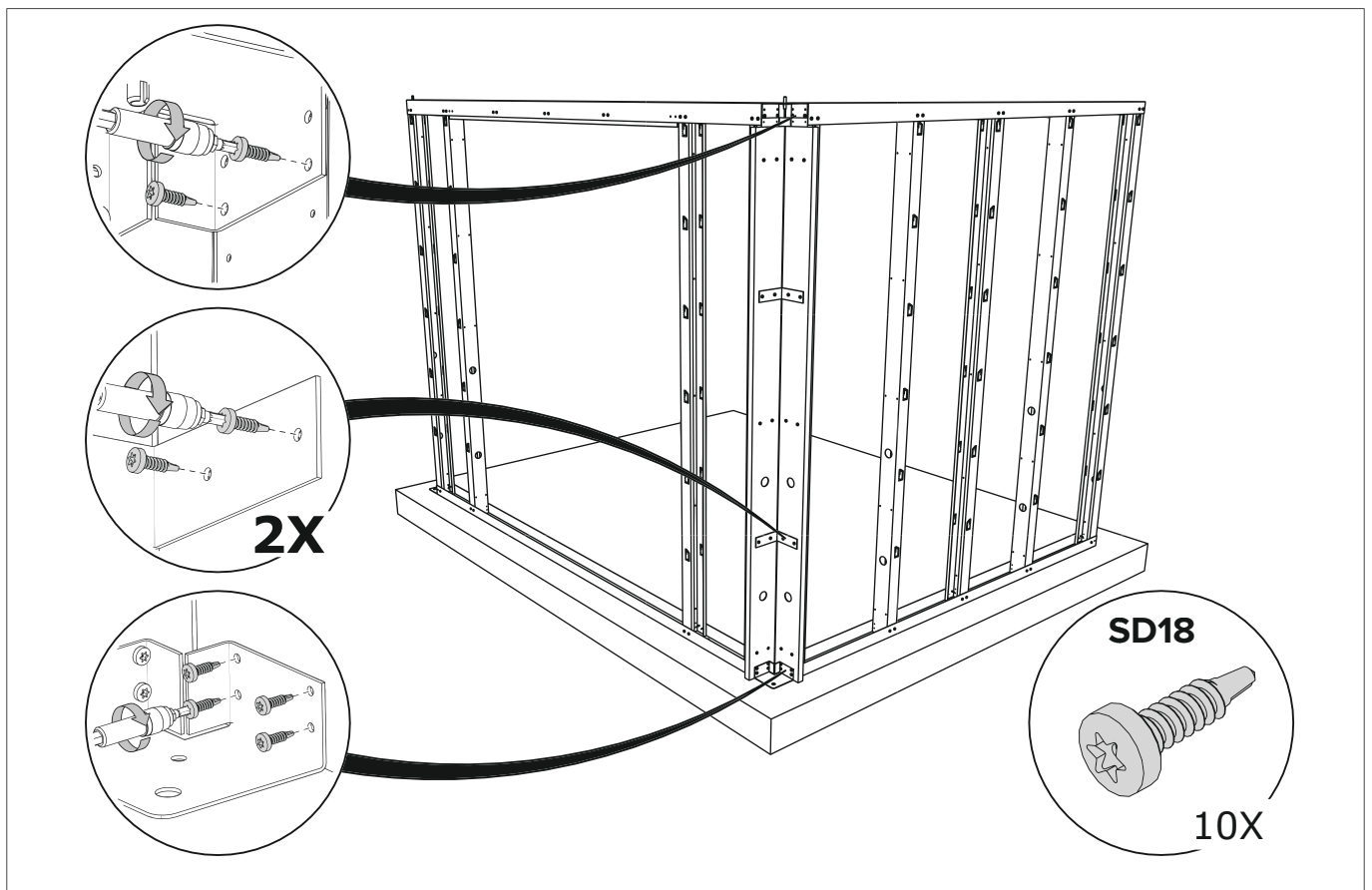

A + B Paroi / Wand / Wall / Wand

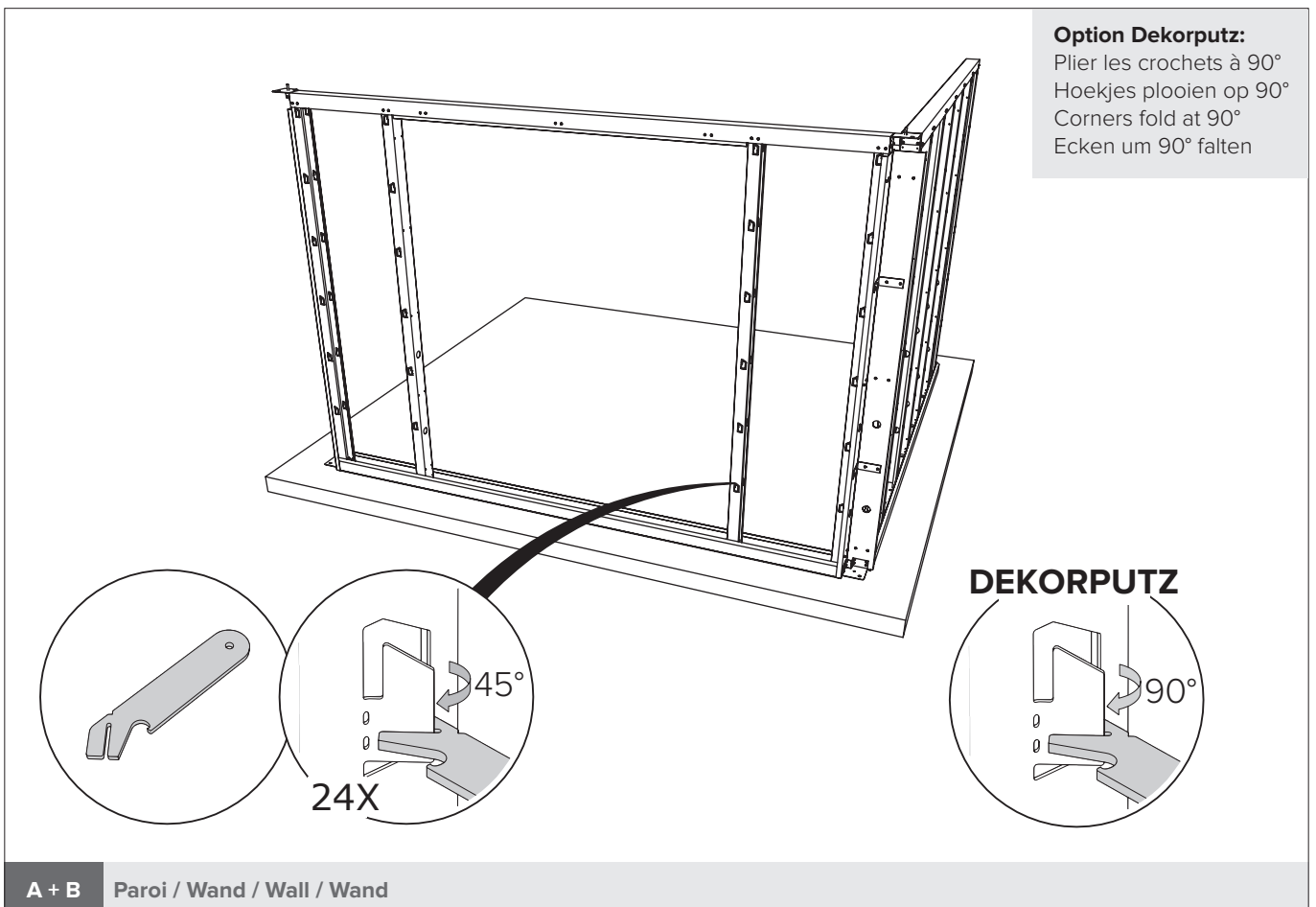
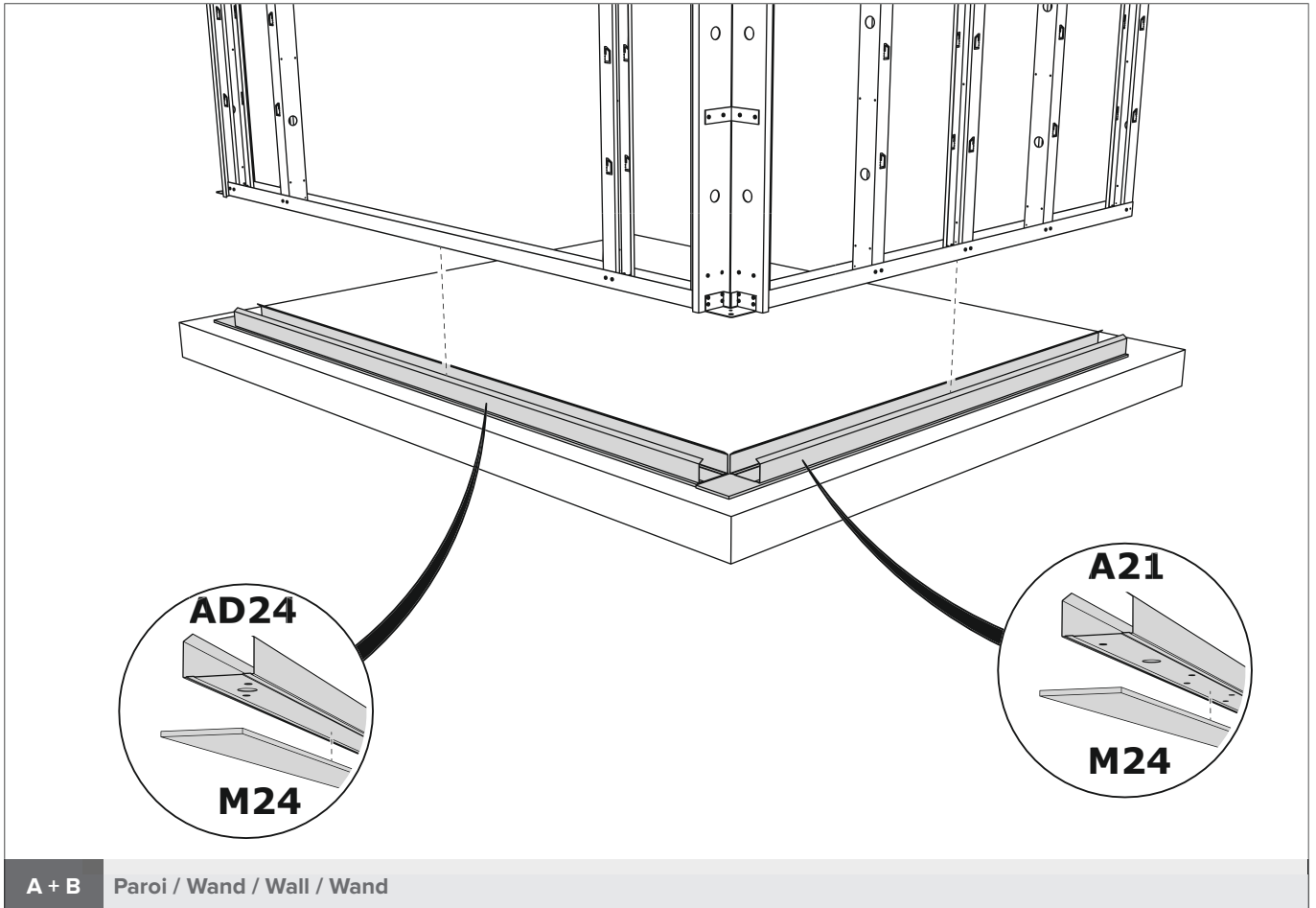

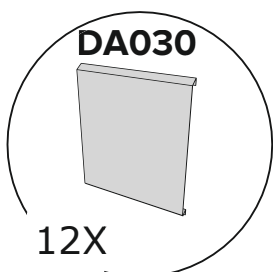
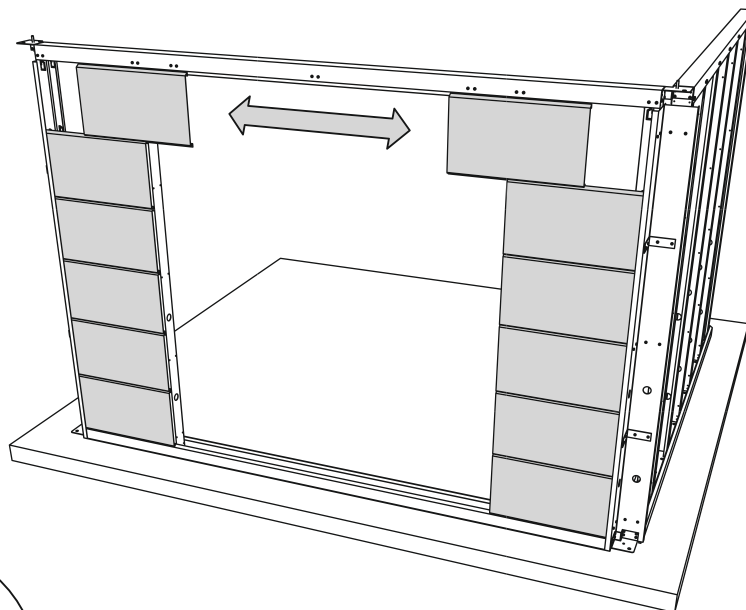

A + B Paroi / Wand / Wall / Wand

Option Dekorputz:

Plier les crochets à 90°
 Hoekjes plooiën op 90°
 Corners fold at 90°
 Ecken um 90° falten

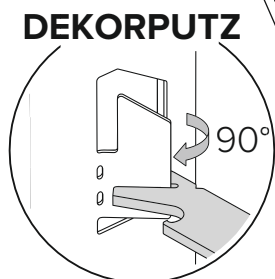
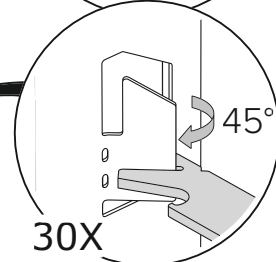
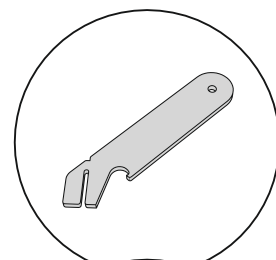
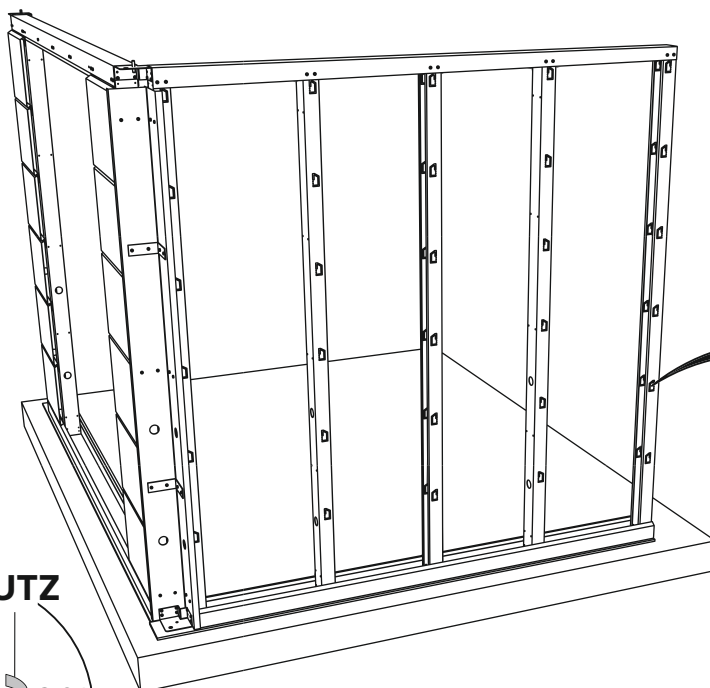

A + B Paroi / Wand / Wall / Wand

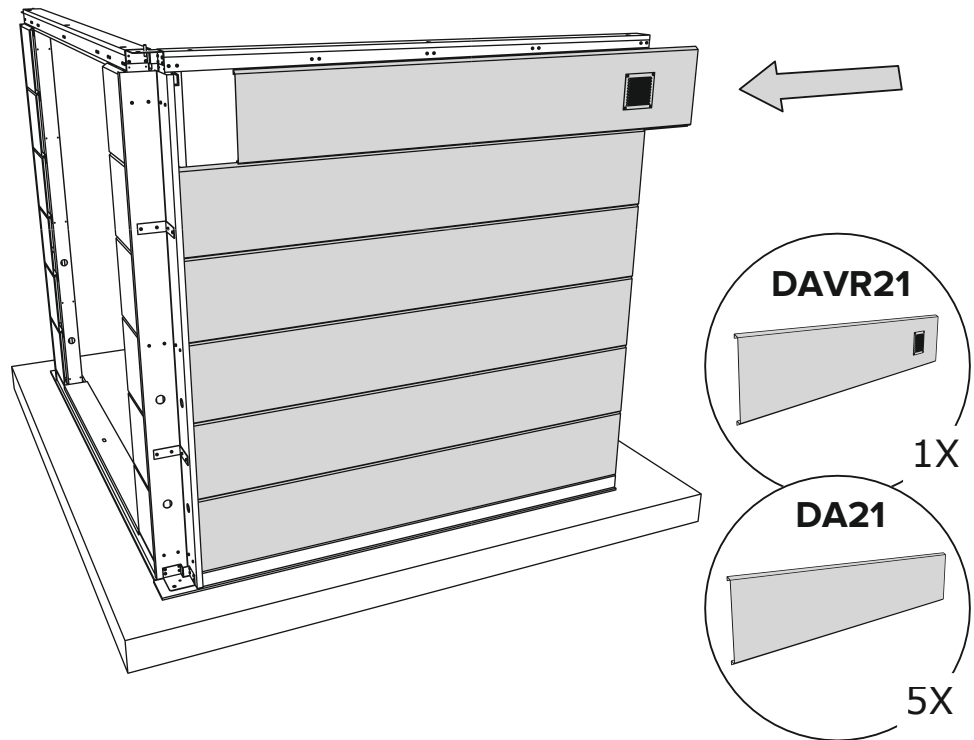

A + B Paroi / Wand / Wall / Wand

revêtement intérieur
binnenbekleding
interior lining
Innenverkleidung

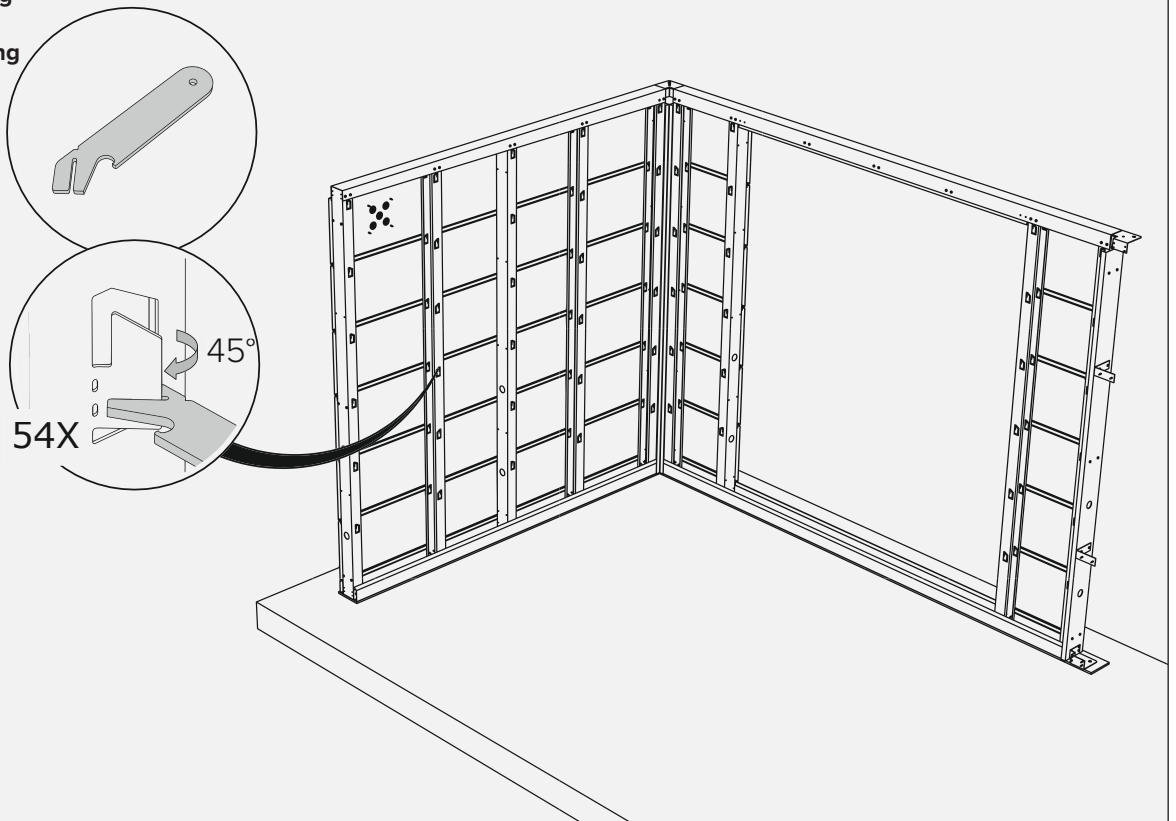

A + B Paroi / Wand / Wall / Wand

Option / Optie / Option / Option

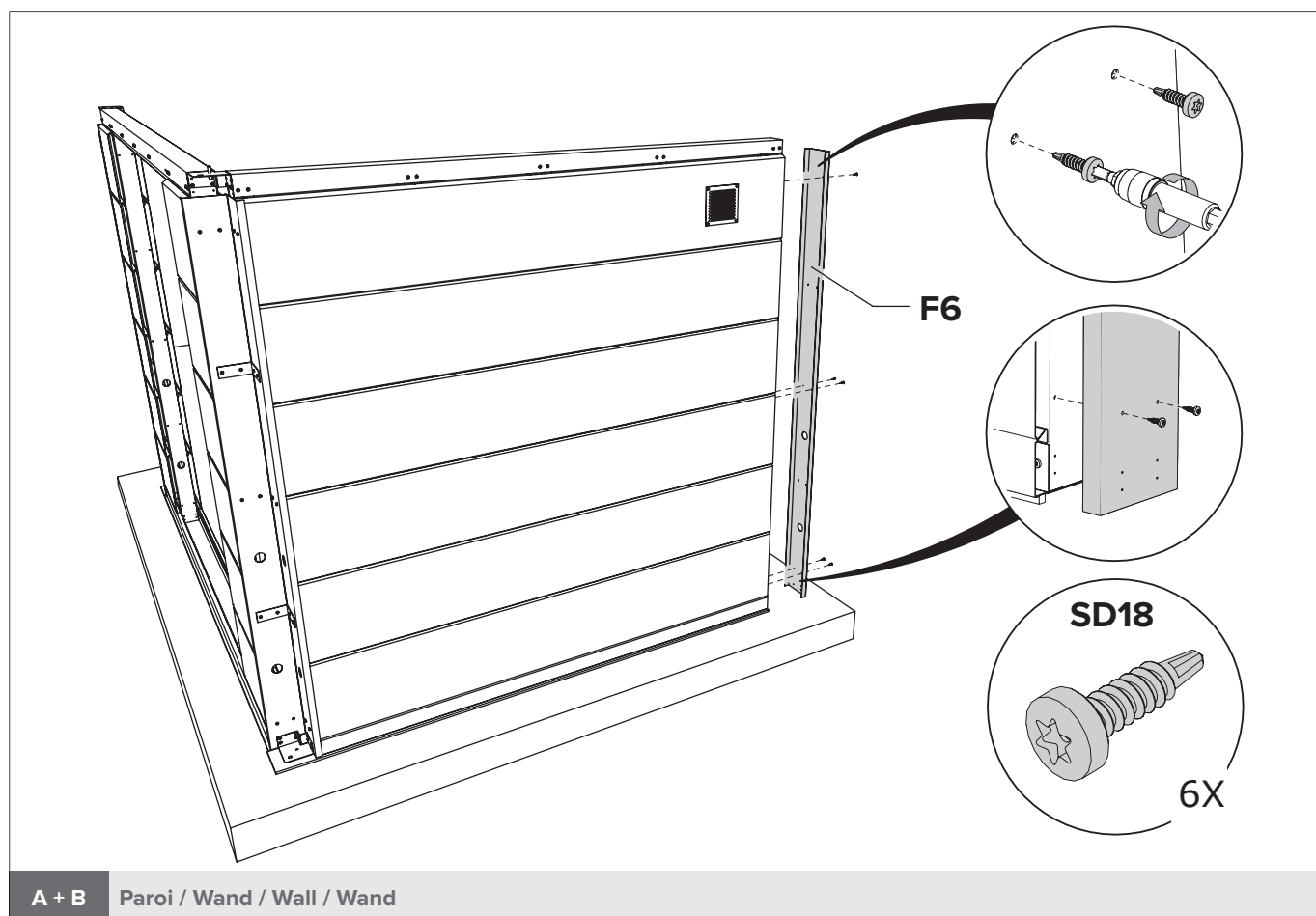
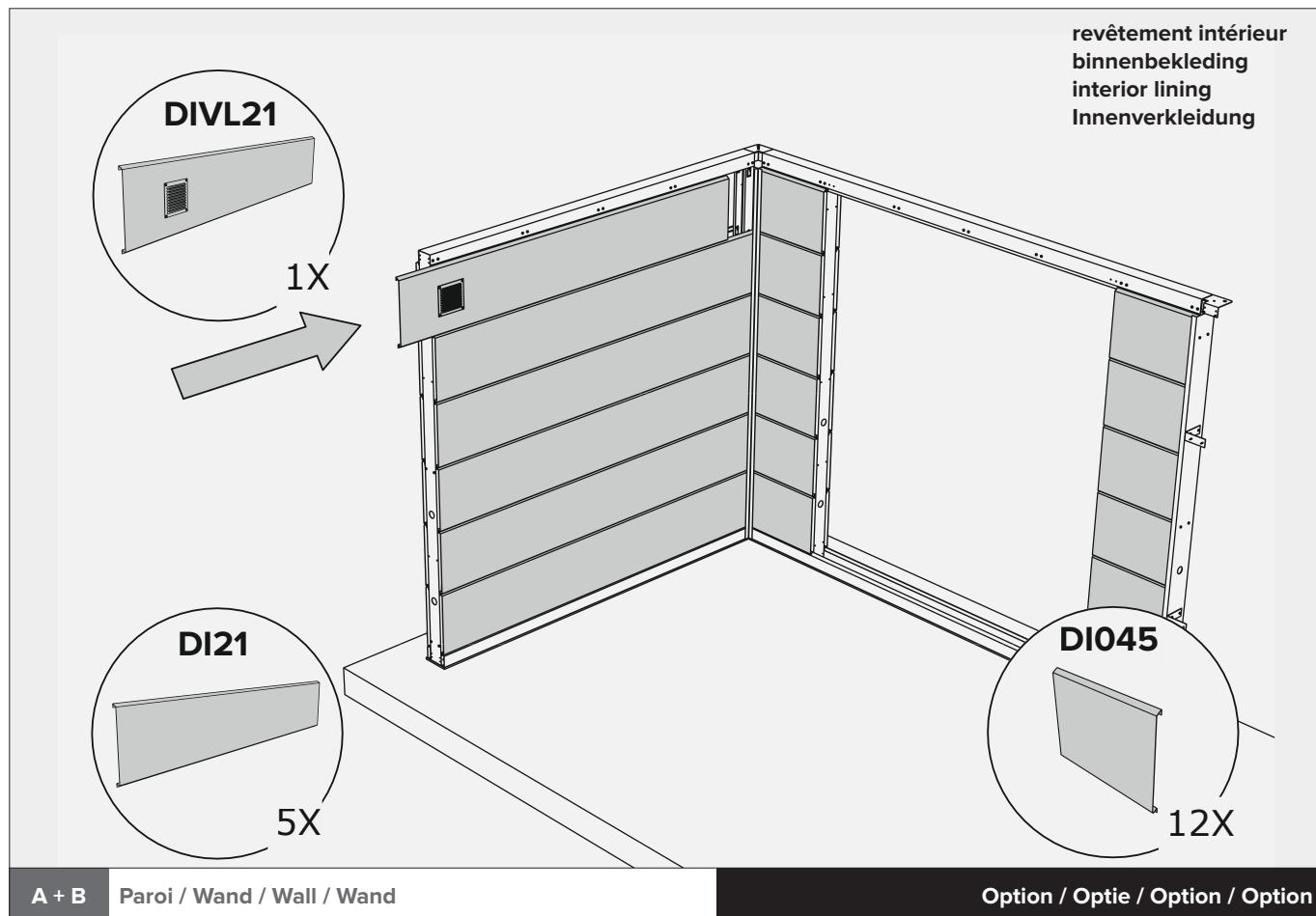

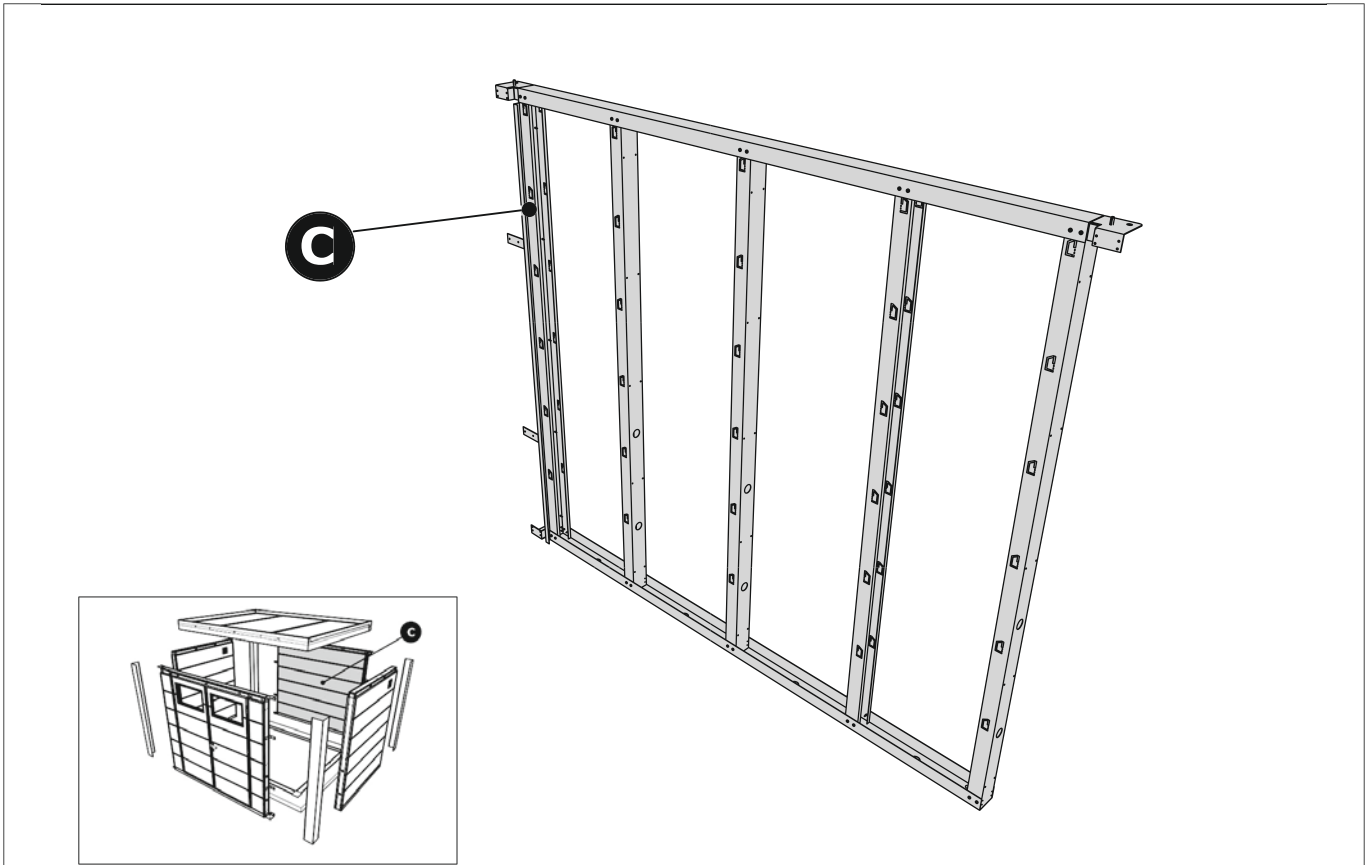

C Paroi / Wand / Wall / Wand

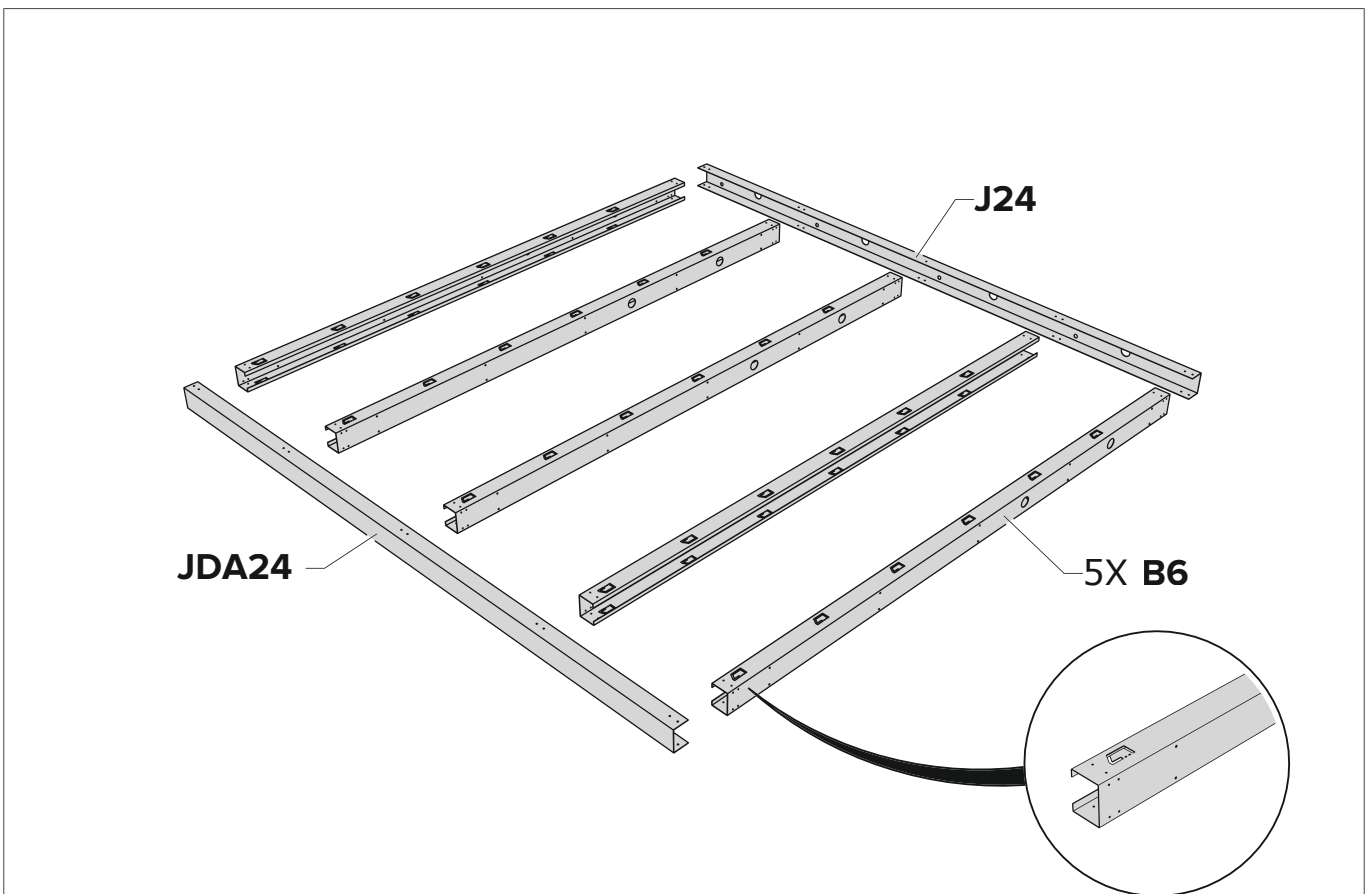

C Paroi / Wand / Wall / Wand

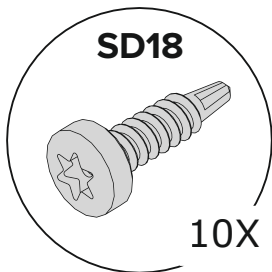
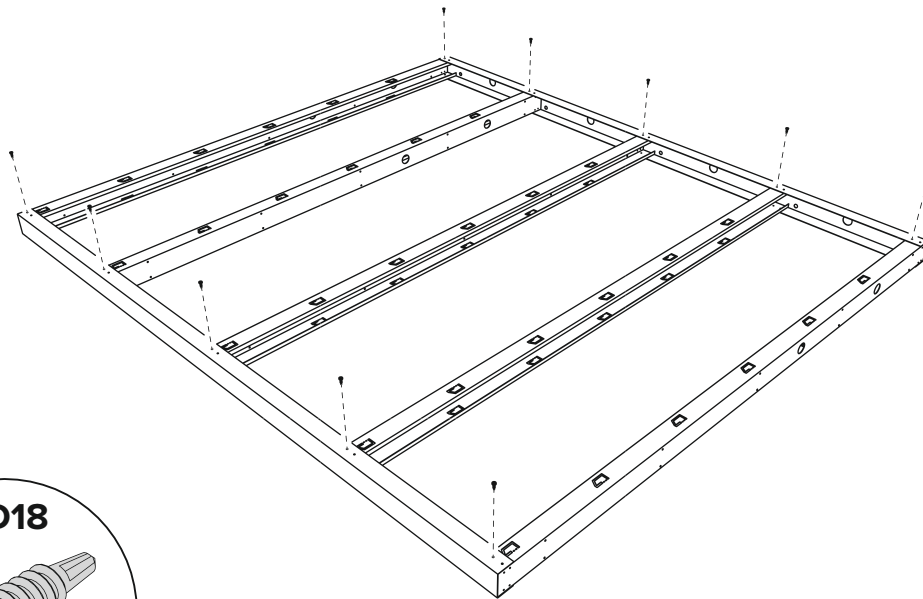

C Paroi / Wand / Wall / Wand

Tourner encadrement / Kader omdraaien / Turn Frame / Rahmen umdrehen

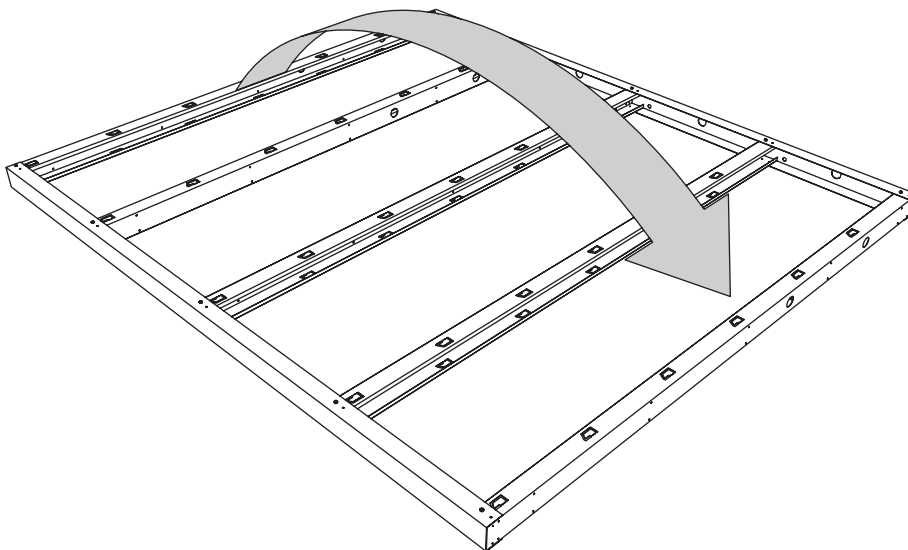

C Paroi / Wand / Wall / Wand

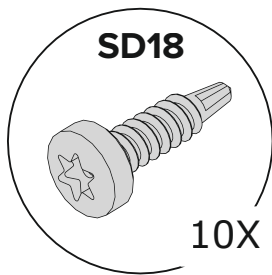
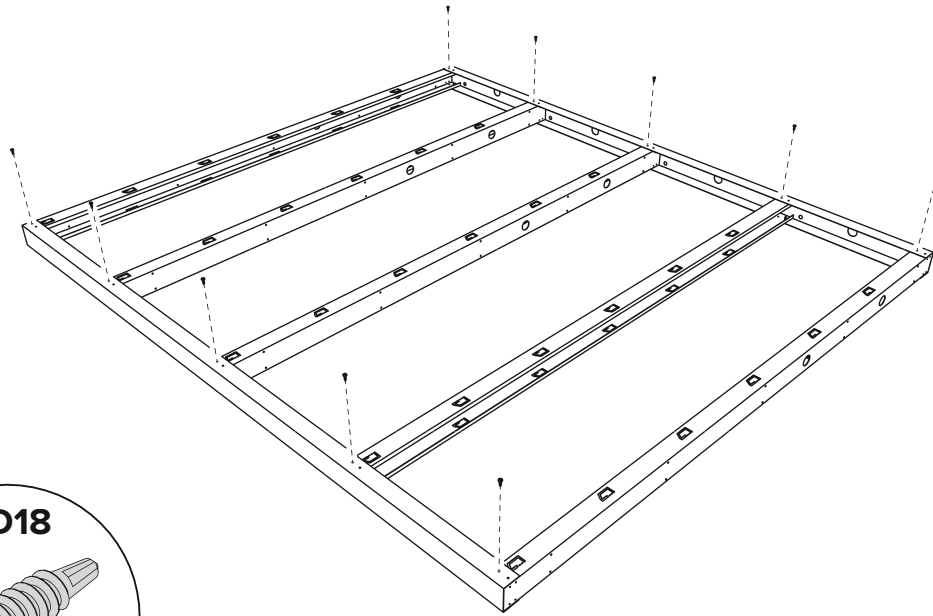

C Paroi / Wand / Wall / Wand

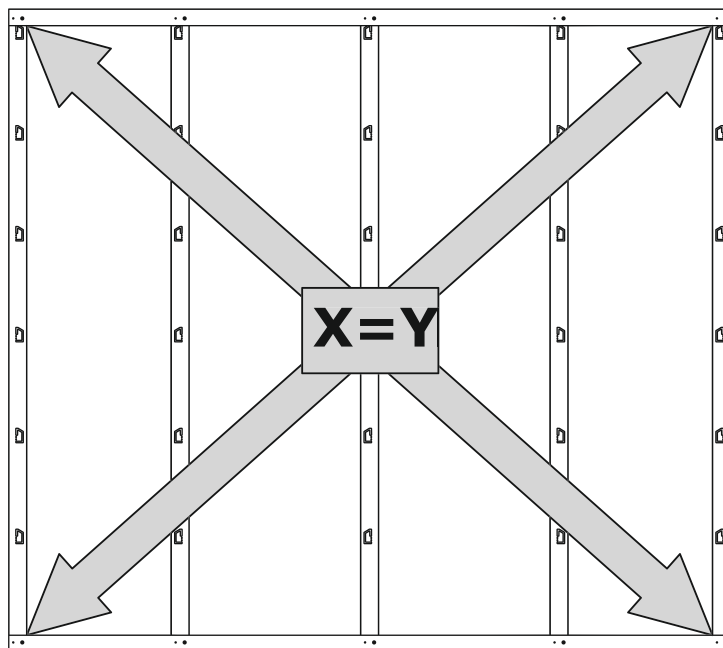
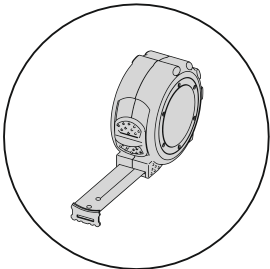

C Paroi / Wand / Wall / Wand

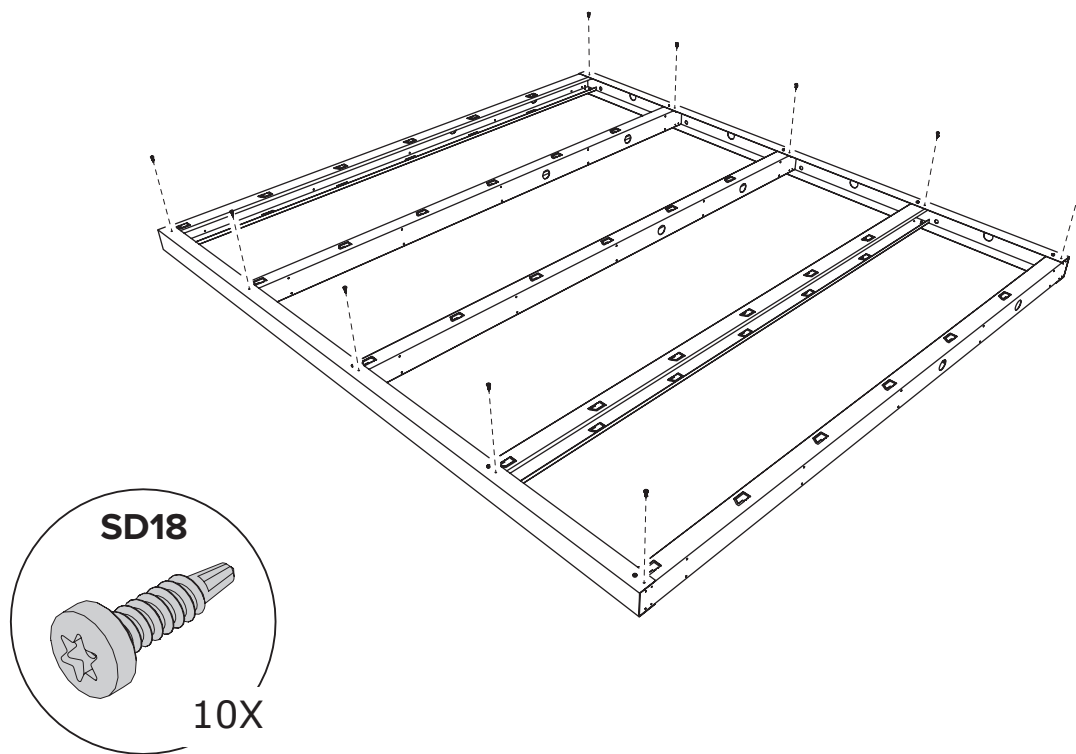

C Paroi / Wand / Wall / Wand

Tourner encadrement / Kader omdraaien / Turn Frame / Rahmen umdrehen

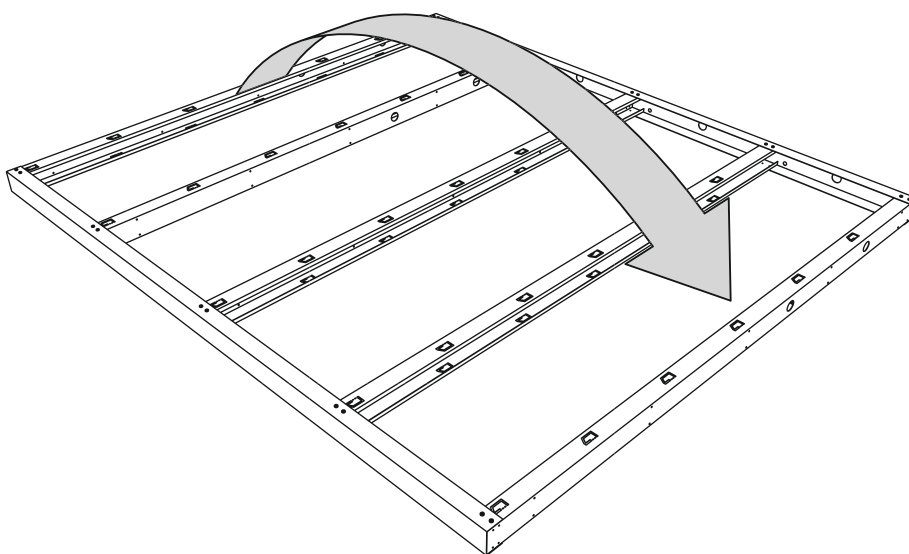

C Paroi / Wand / Wall / Wand

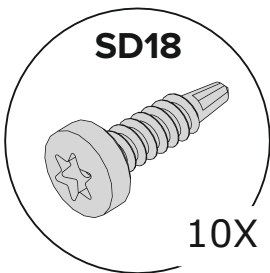
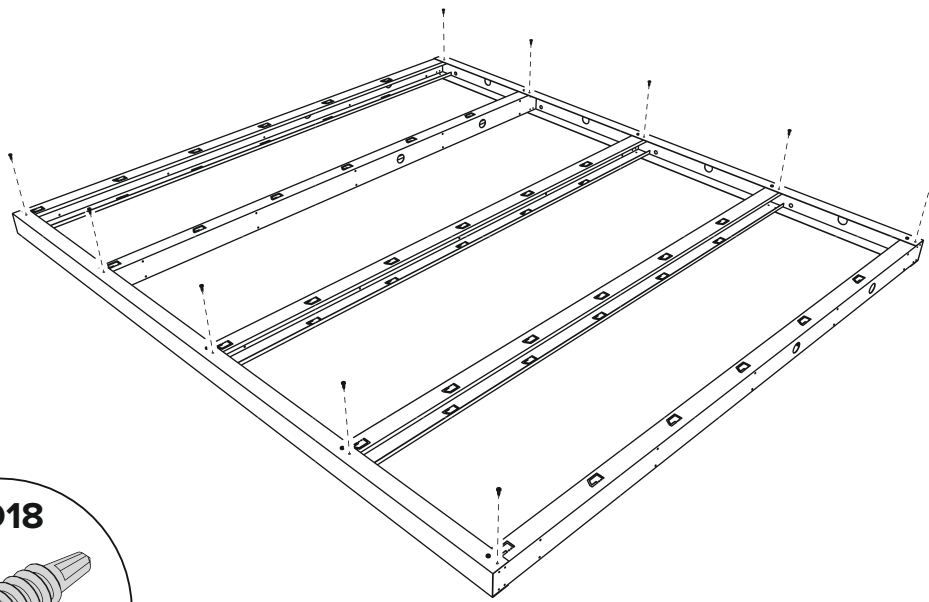

C Paroi / Wand / Wall / Wand

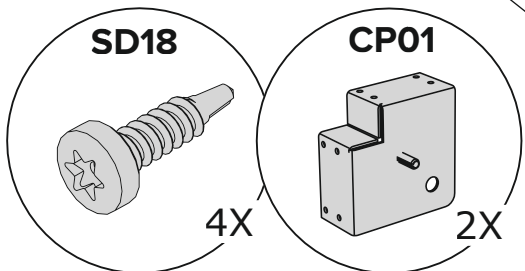
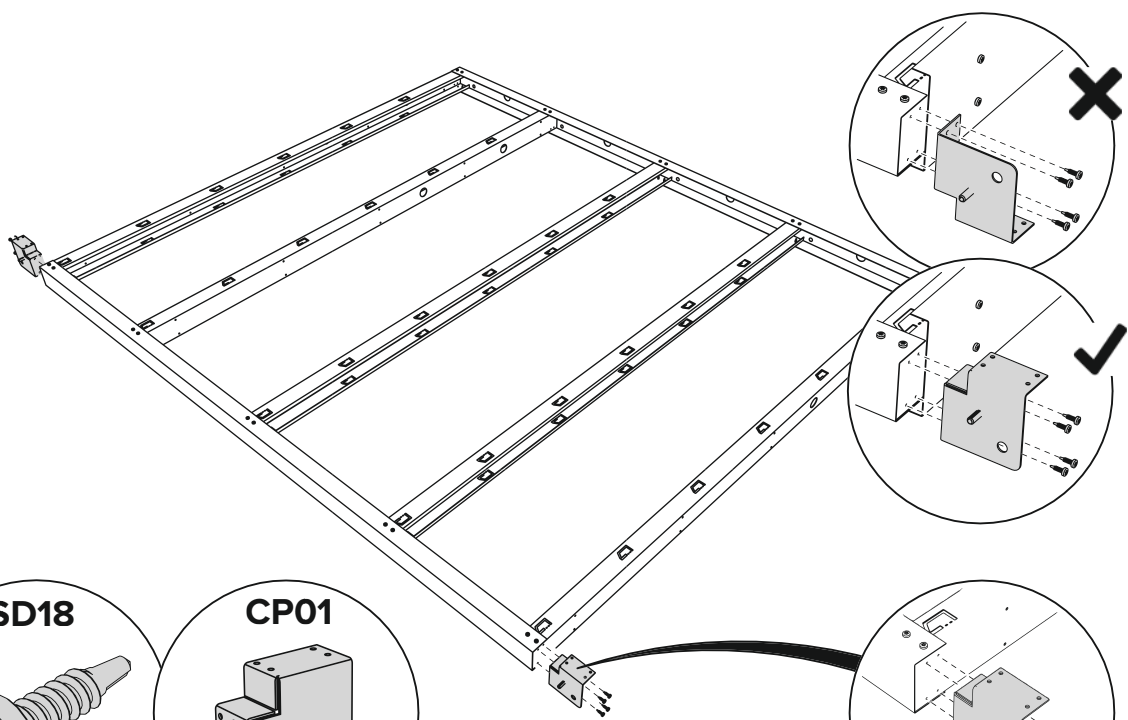

C Paroi / Wand / Wall / Wand

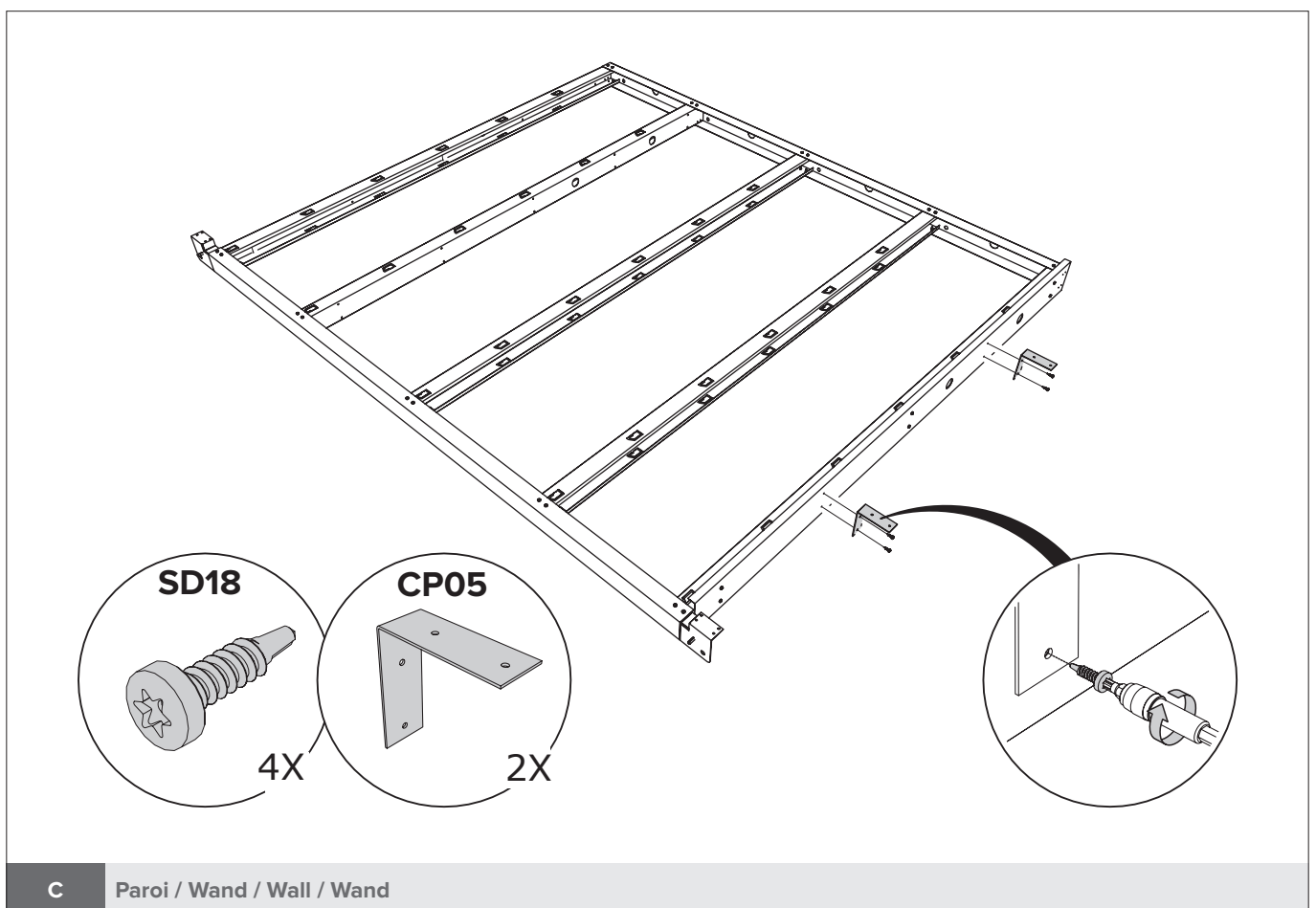
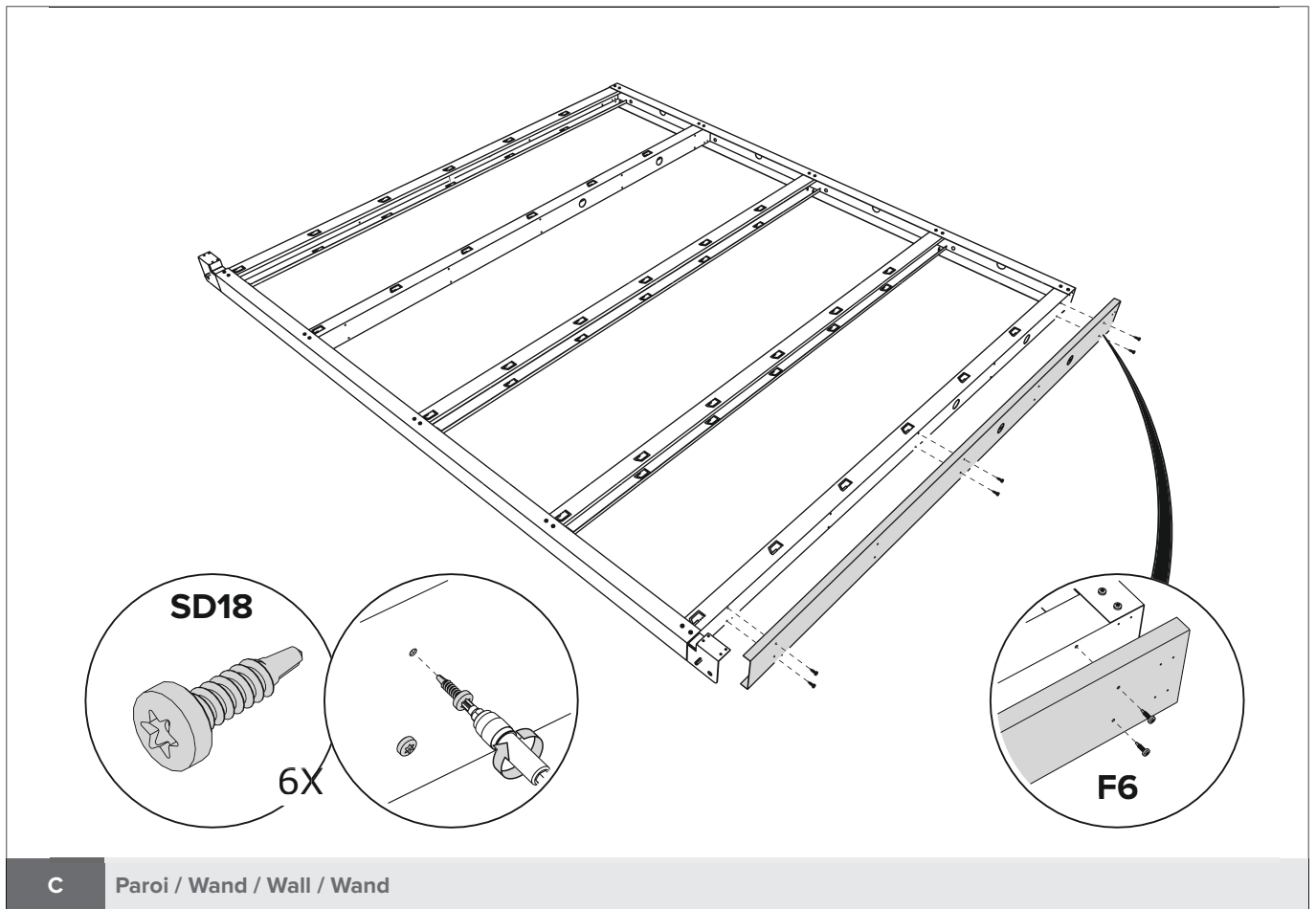

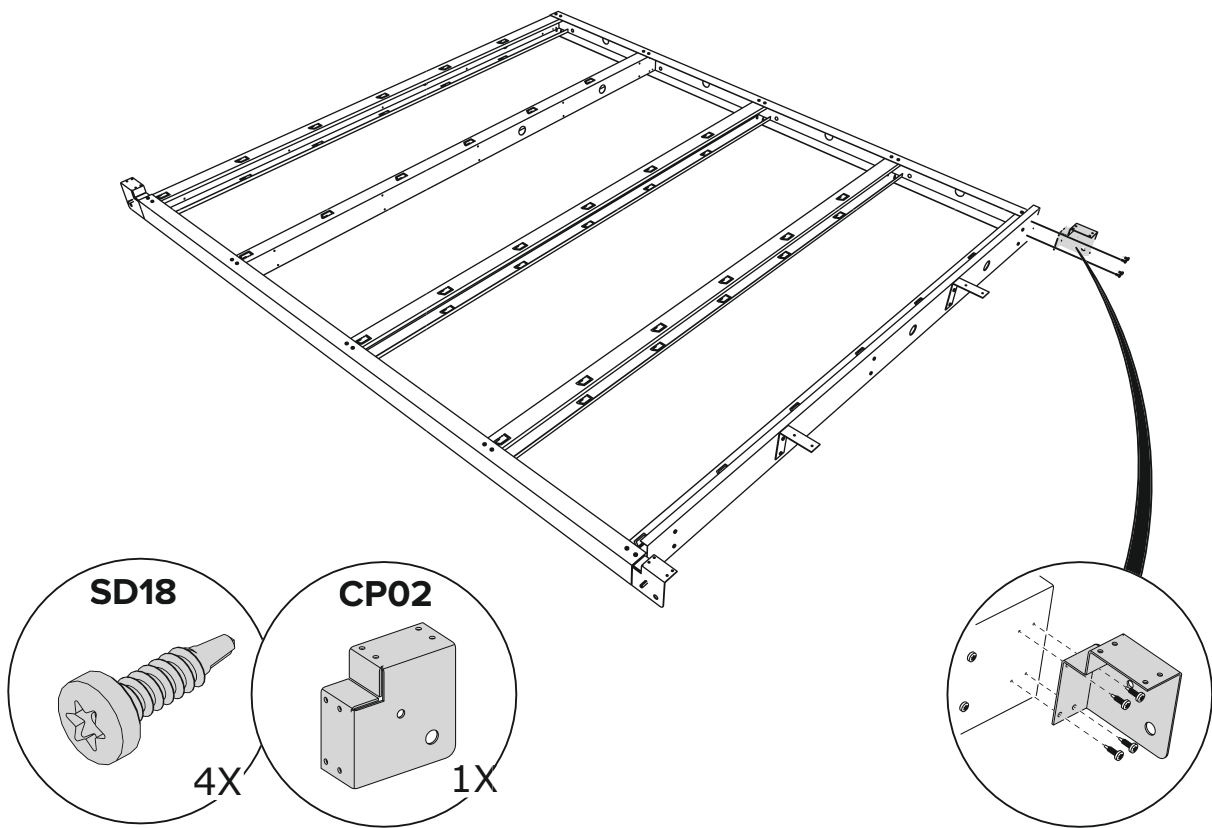

C Paroi / Wand / Wall / Wand

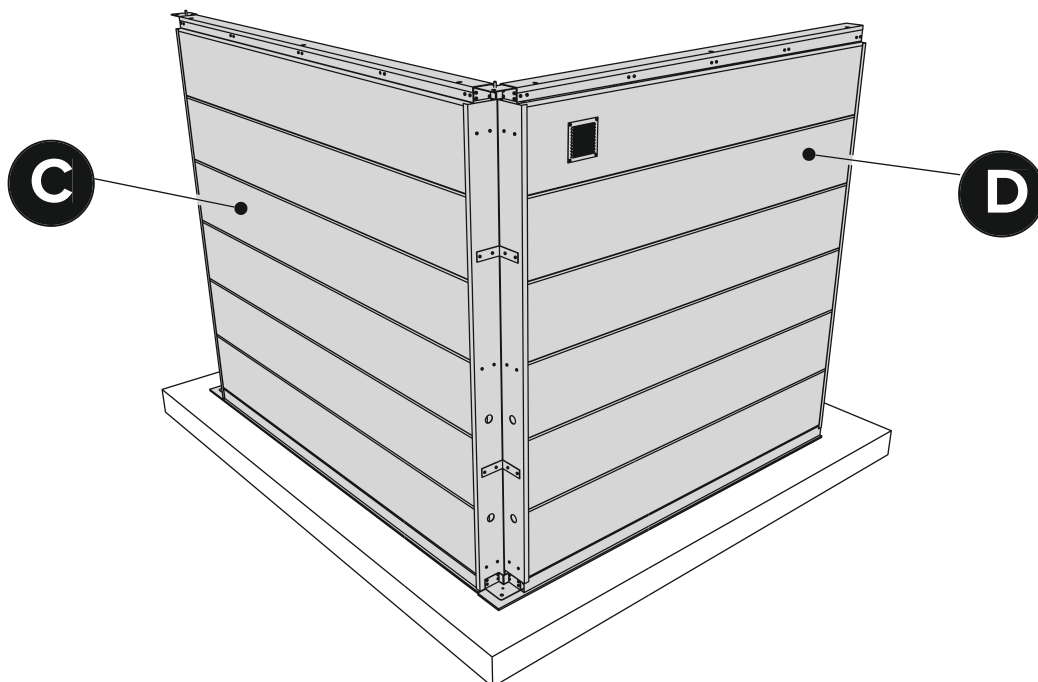

C + D Paroi / Wand / Wall / Wand

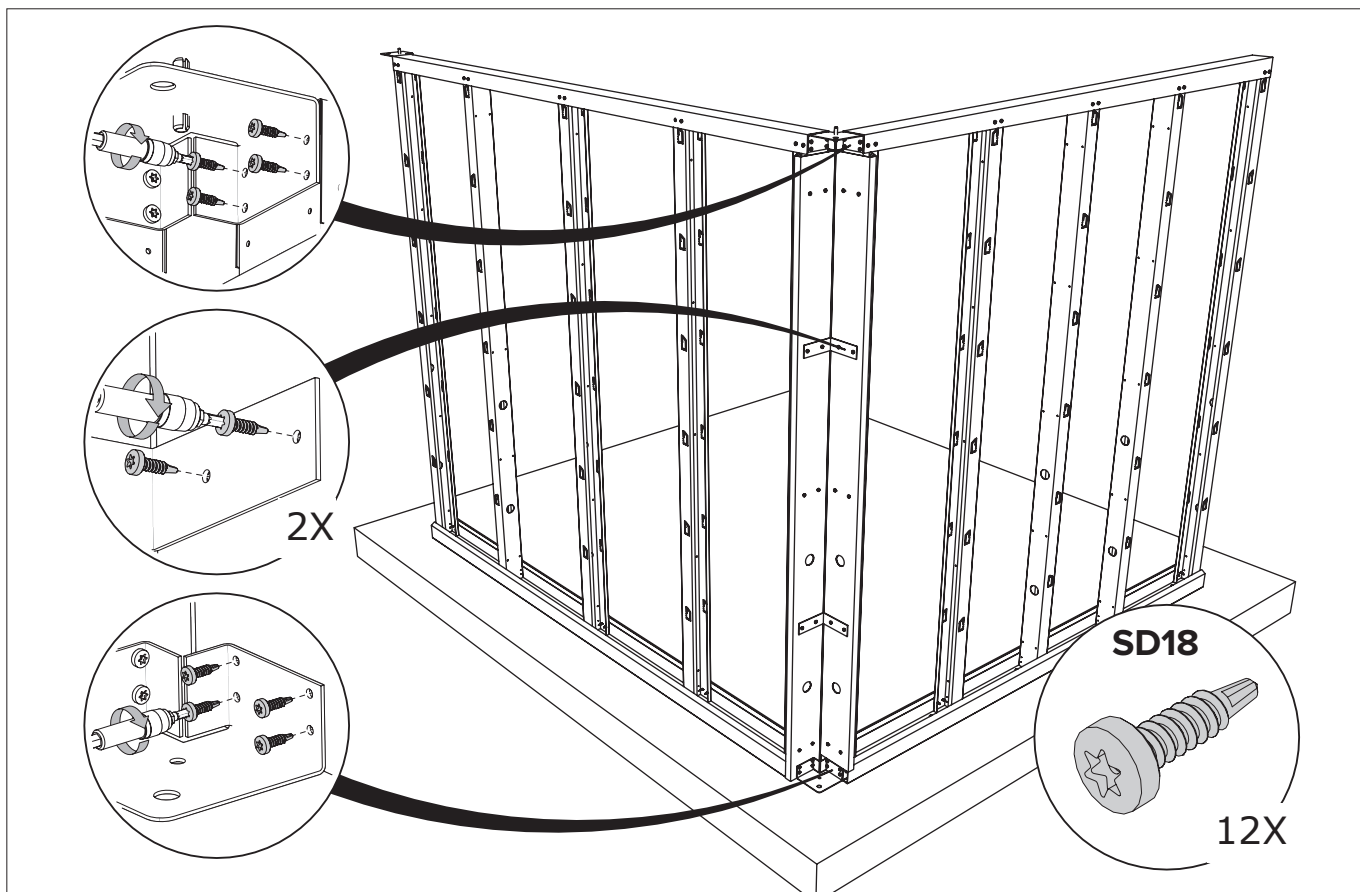

C + D Paroi / Wand / Wall / Wand

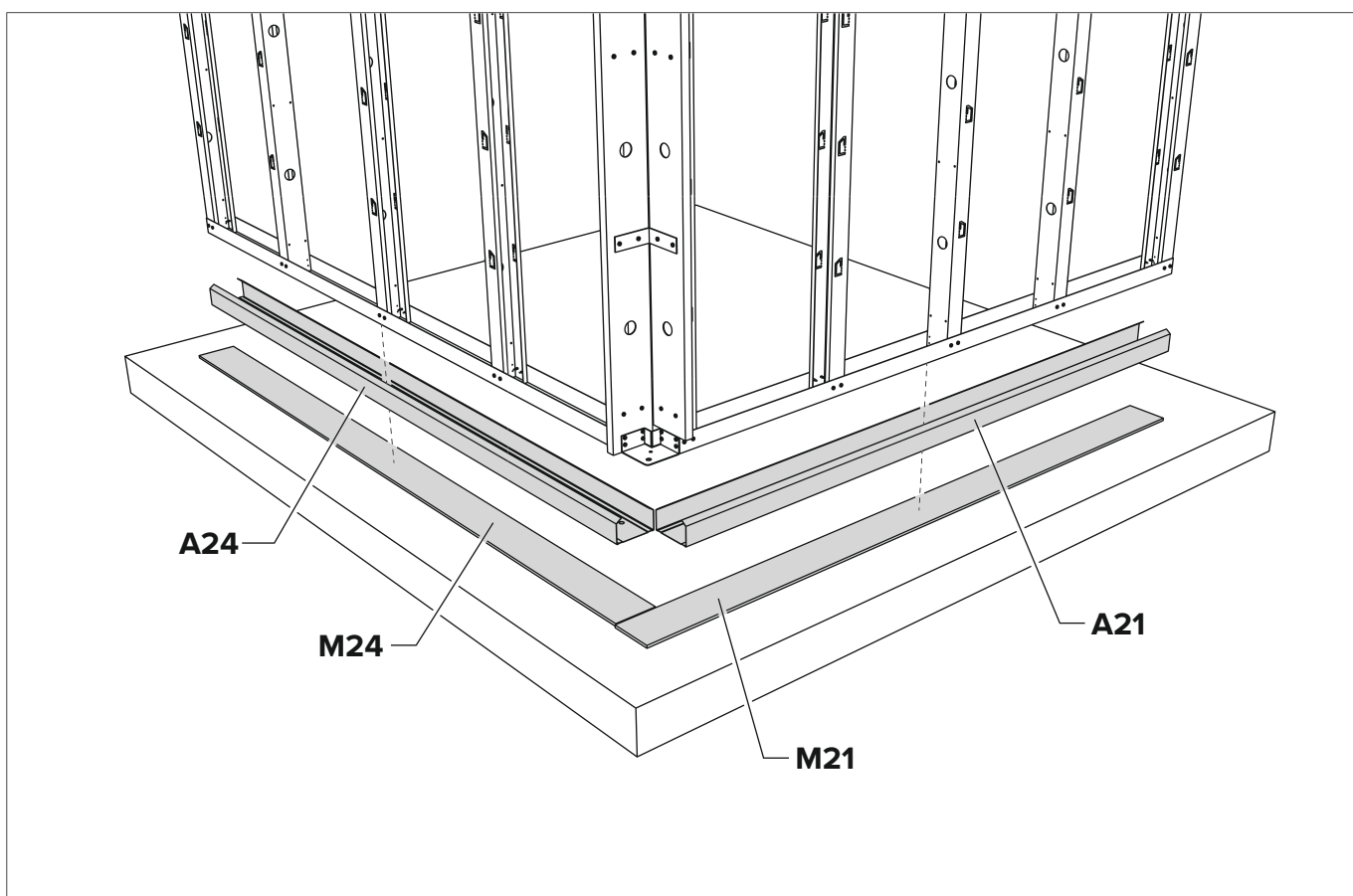

C + D Paroi / Wand / Wall / Wand

Option Dekorputz:

Plier les crochets à 90°
 Hoekjes plooiën op 90°
 Corners fold at 90°
 Ecken um 90° falten

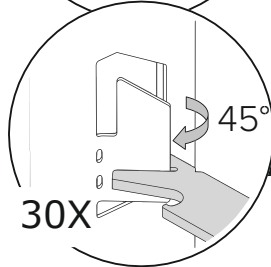
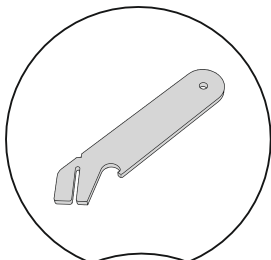

DEKORPUTZ

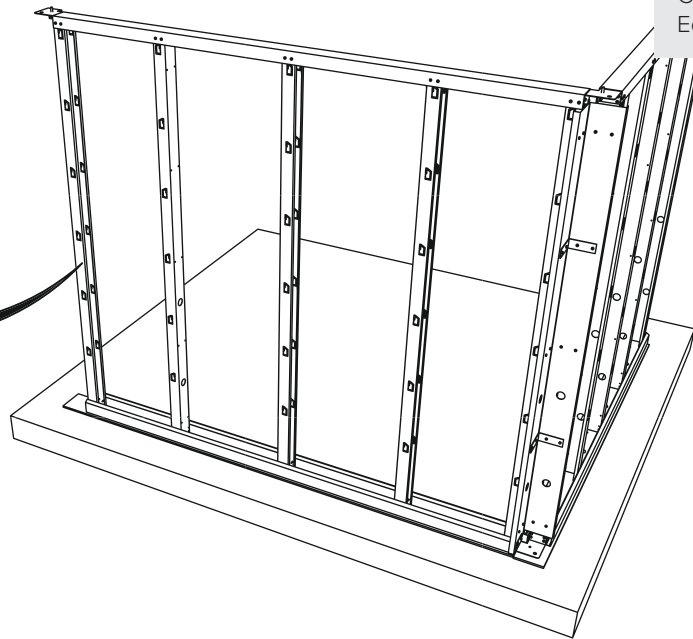
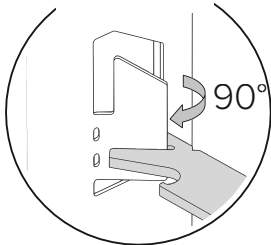

C + D Paroi / Wand / Wall / Wand

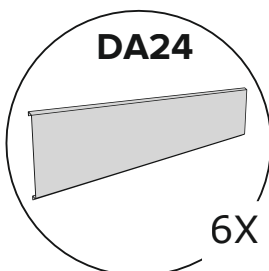
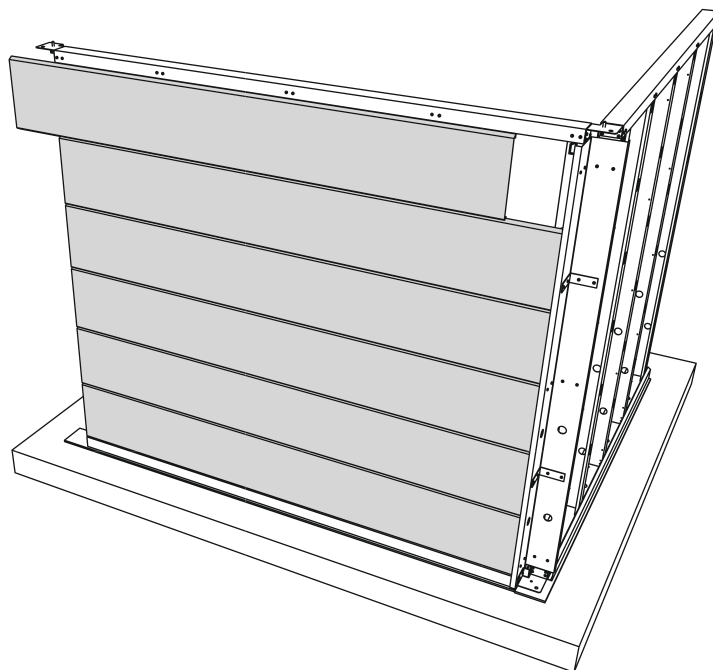

C + D Paroi / Wand / Wall / Wand

Option Dekorputz:

Plier les crochets à 90°
 Hoekjes plooiën op 90°
 Corners fold at 90°
 Ecken um 90° falten

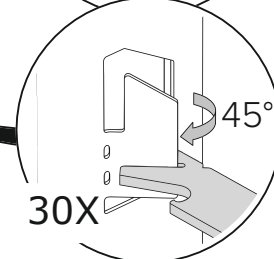
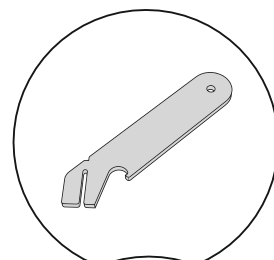
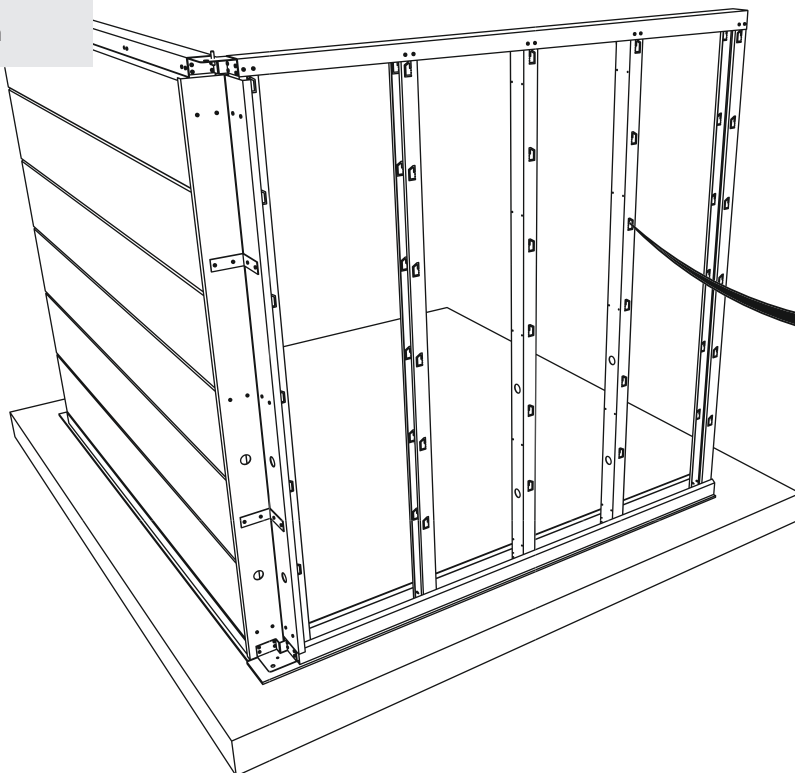

DEKORPUTZ

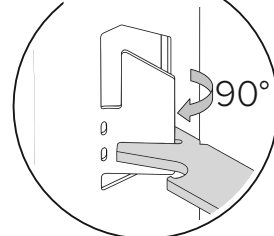

C + D Paroi / Wand / Wall / Wand

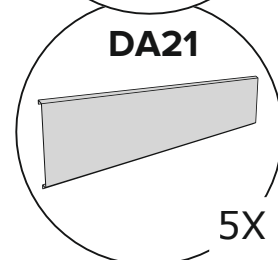
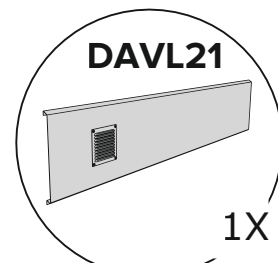
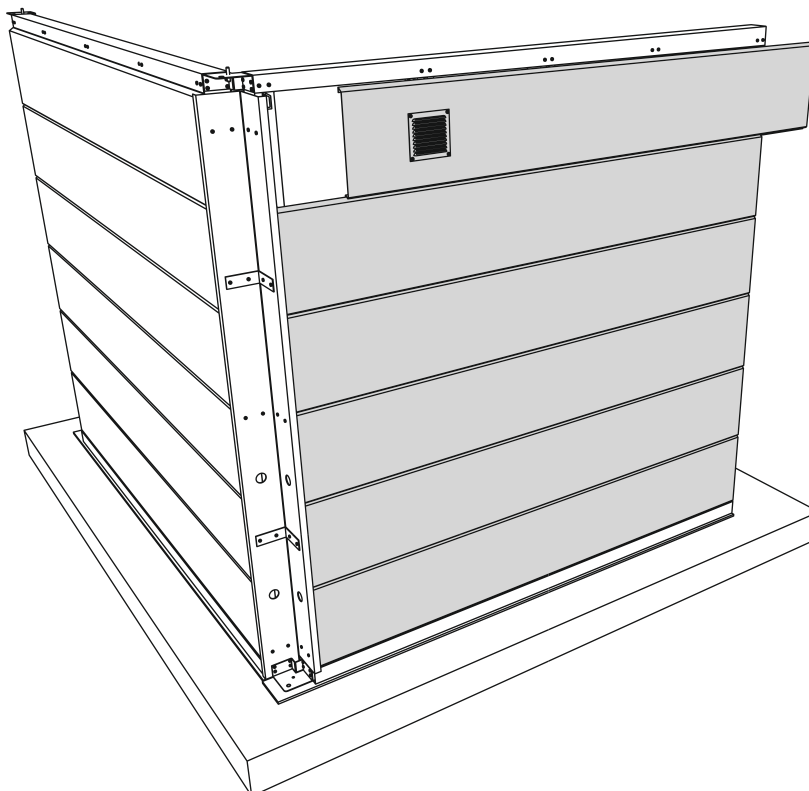

C + D Paroi / Wand / Wall / Wand

revêtement intérieur
 binnenbekleding
 interior lining
 Innenverkleidung

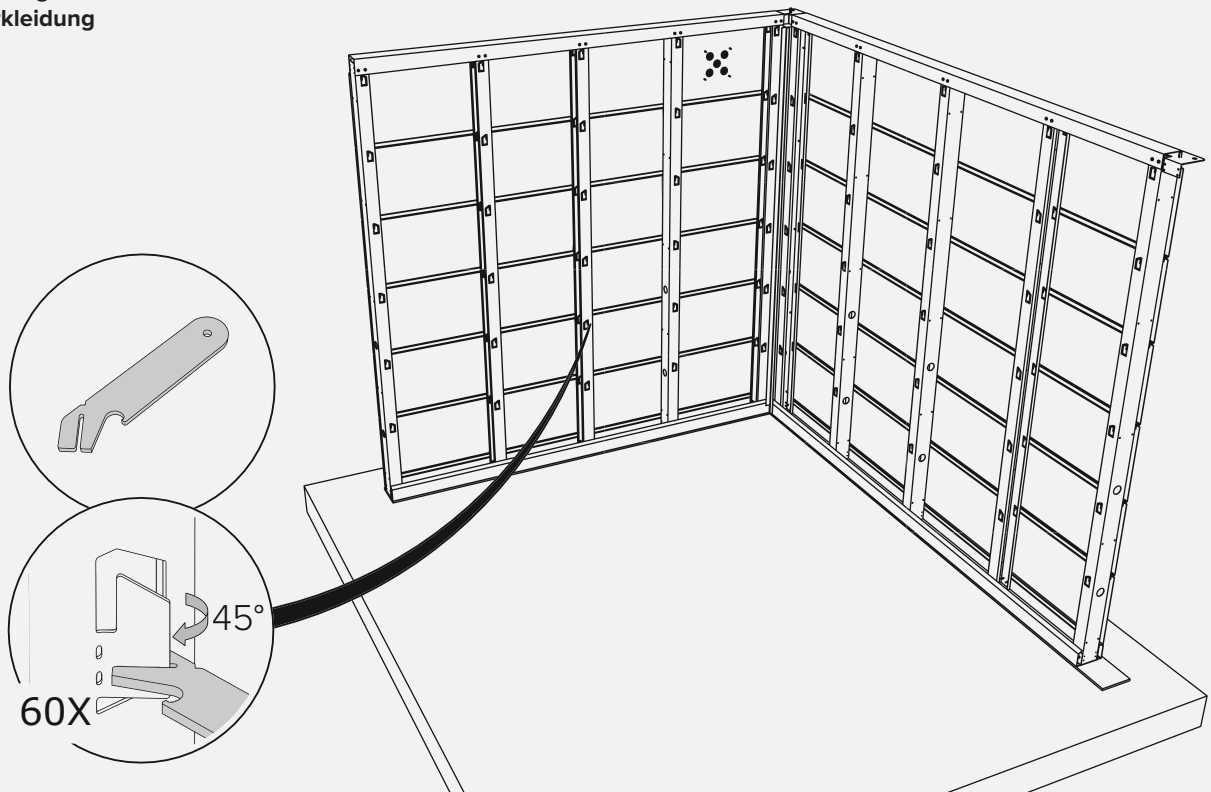

C + D Paroi / Wand / Wall / Wand

Option / Optie / Option / Option

revêtement intérieur et plaque perforée
 binnenbekleding en geperforeerde plaat
 interior lining and perforated plate
 Innenverkleidung und perforierte Platte

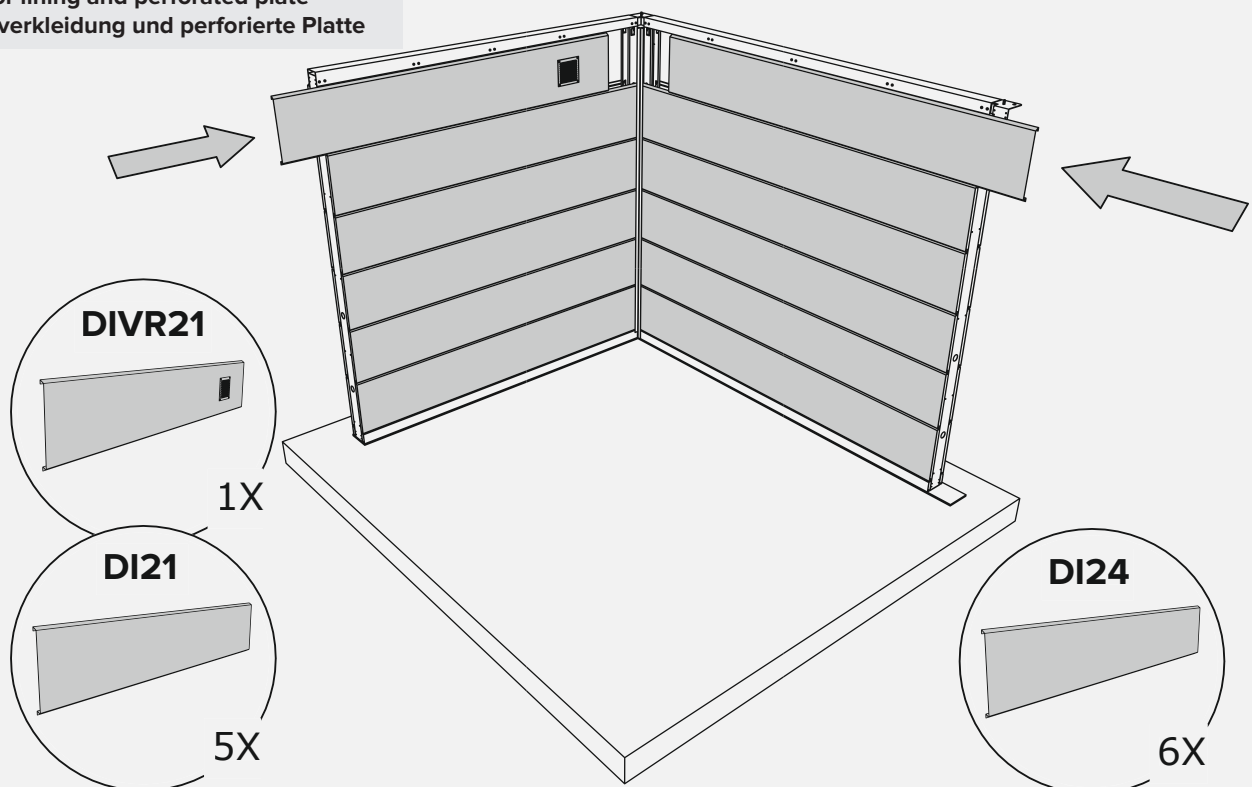

C + D Paroi / Wand / Wall / Wand

Option / Optie / Option / Option

revêtement intérieur et plaque perforée
binnenbekleding en geperforeerde plaat
interior lining and perforated plate
Innenverkleidung und perforierte Platte

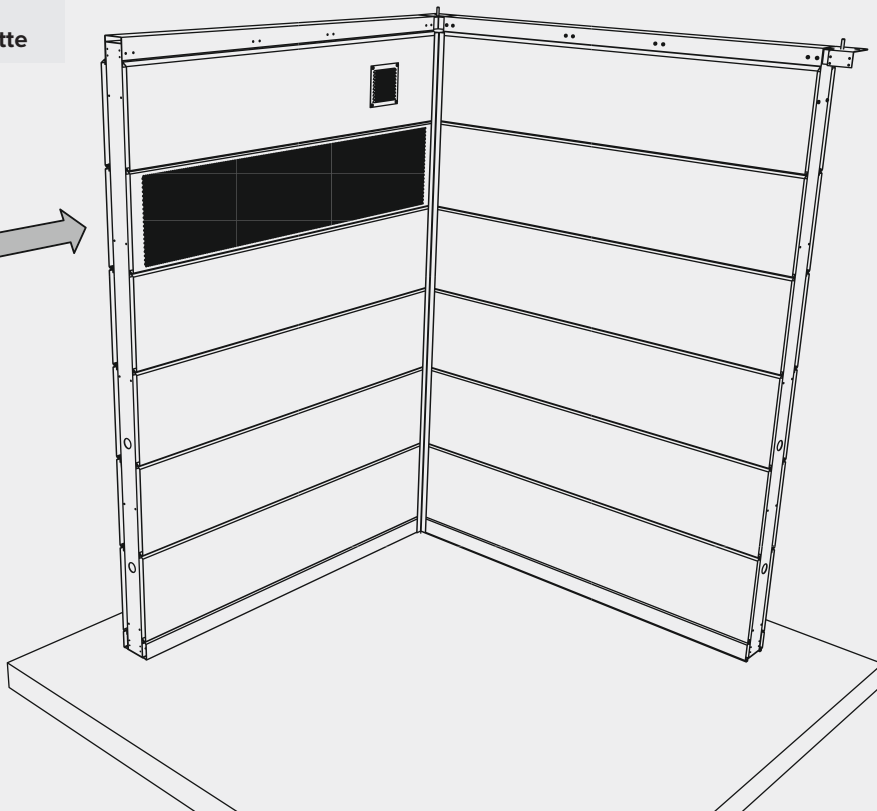
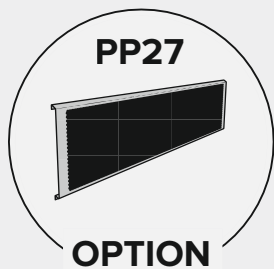
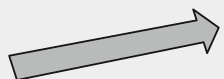

C + D Paroi / Wand / Wall / Wand

Option / Optie / Option / Option

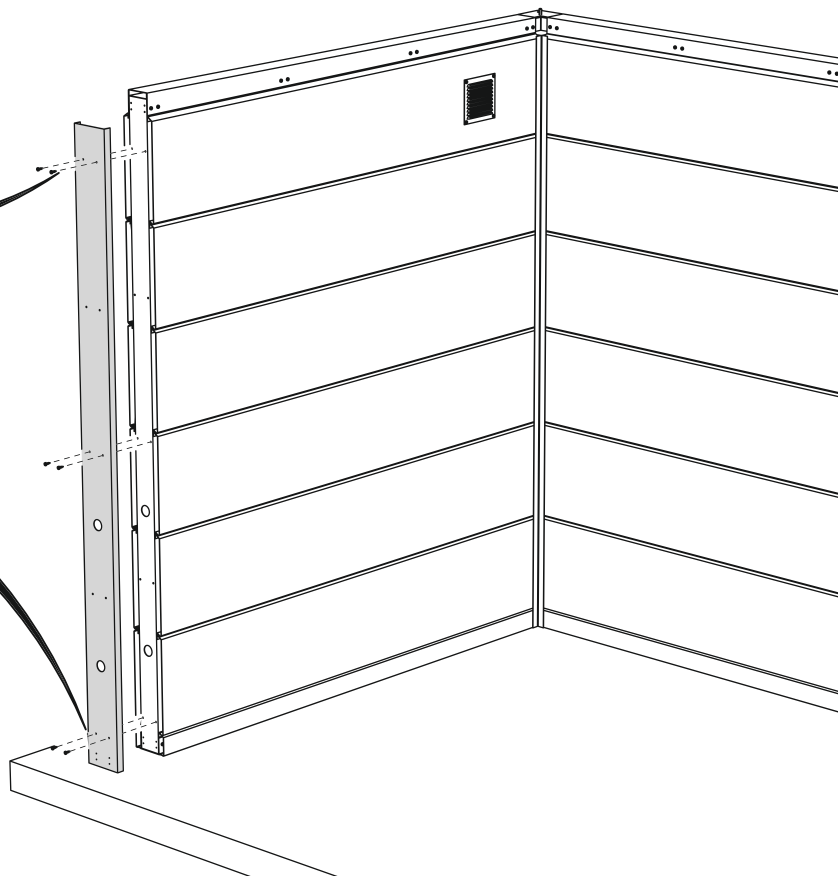
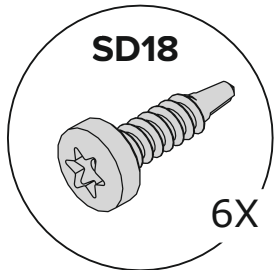
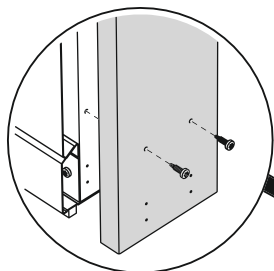
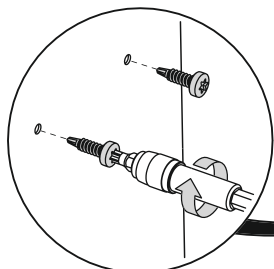

C + D Paroi / Wand / Wall / Wand

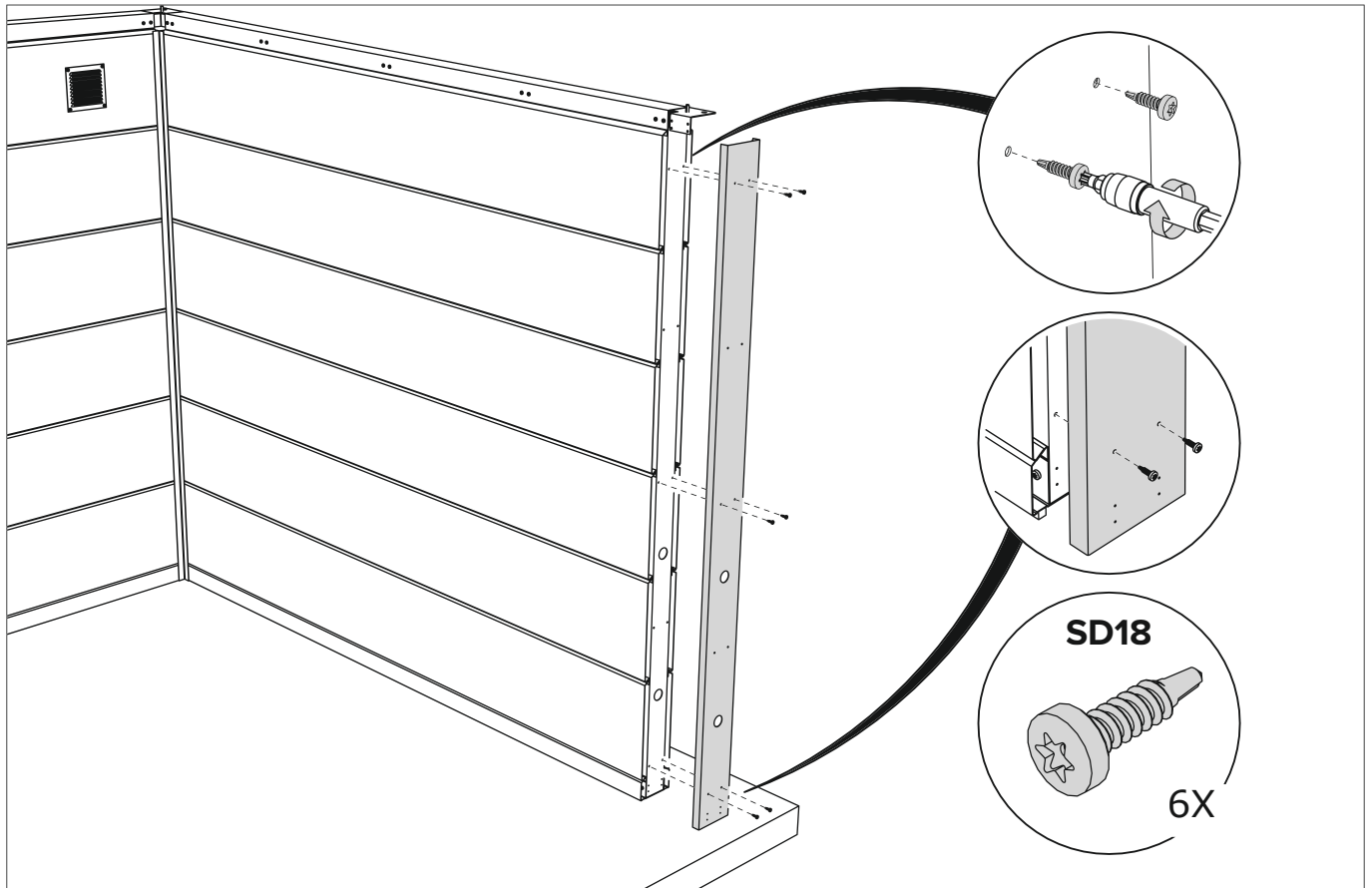

C + D Paroi / Wand / Wall / Wand

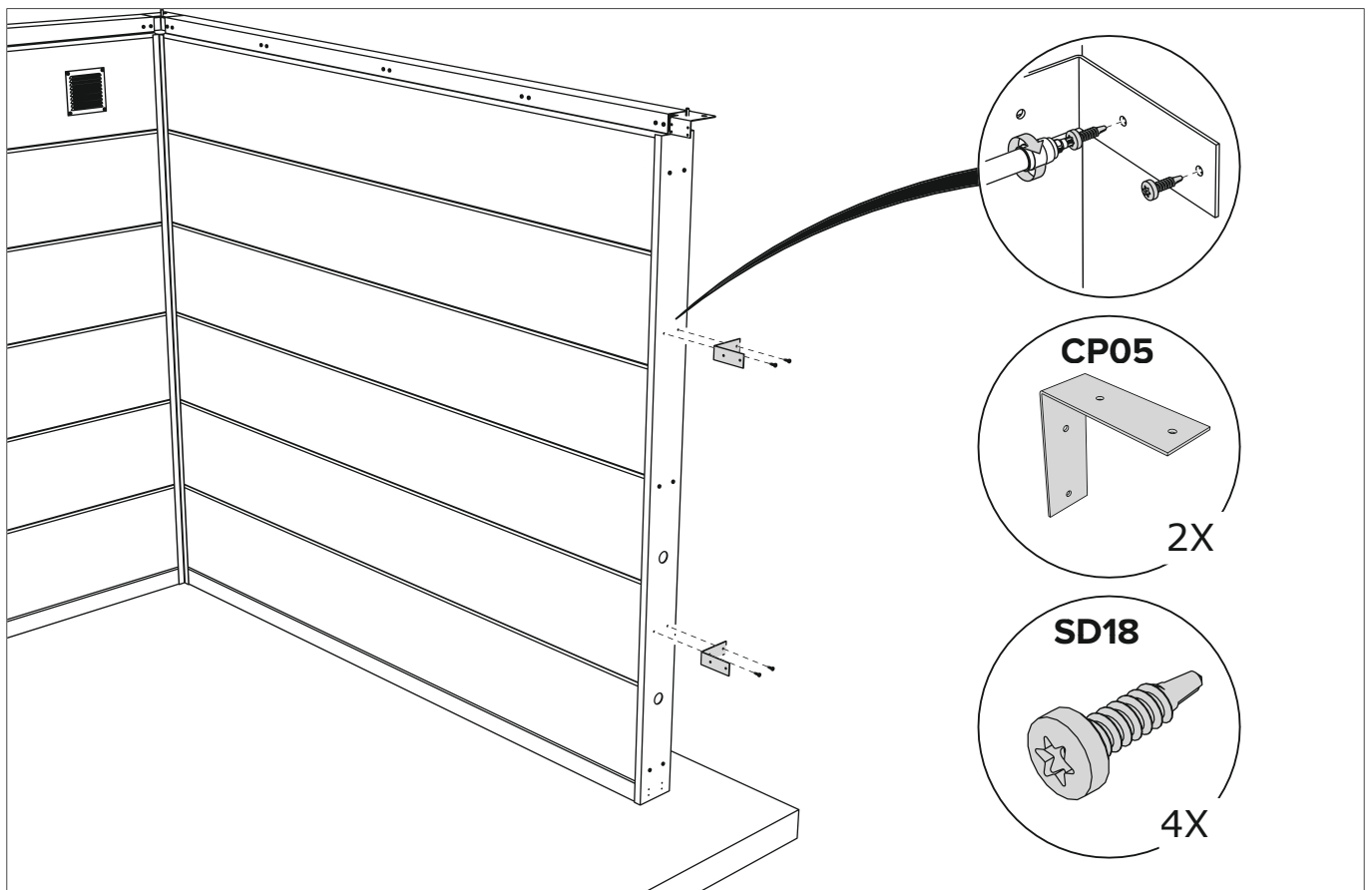

C + D Paroi / Wand / Wall / Wand

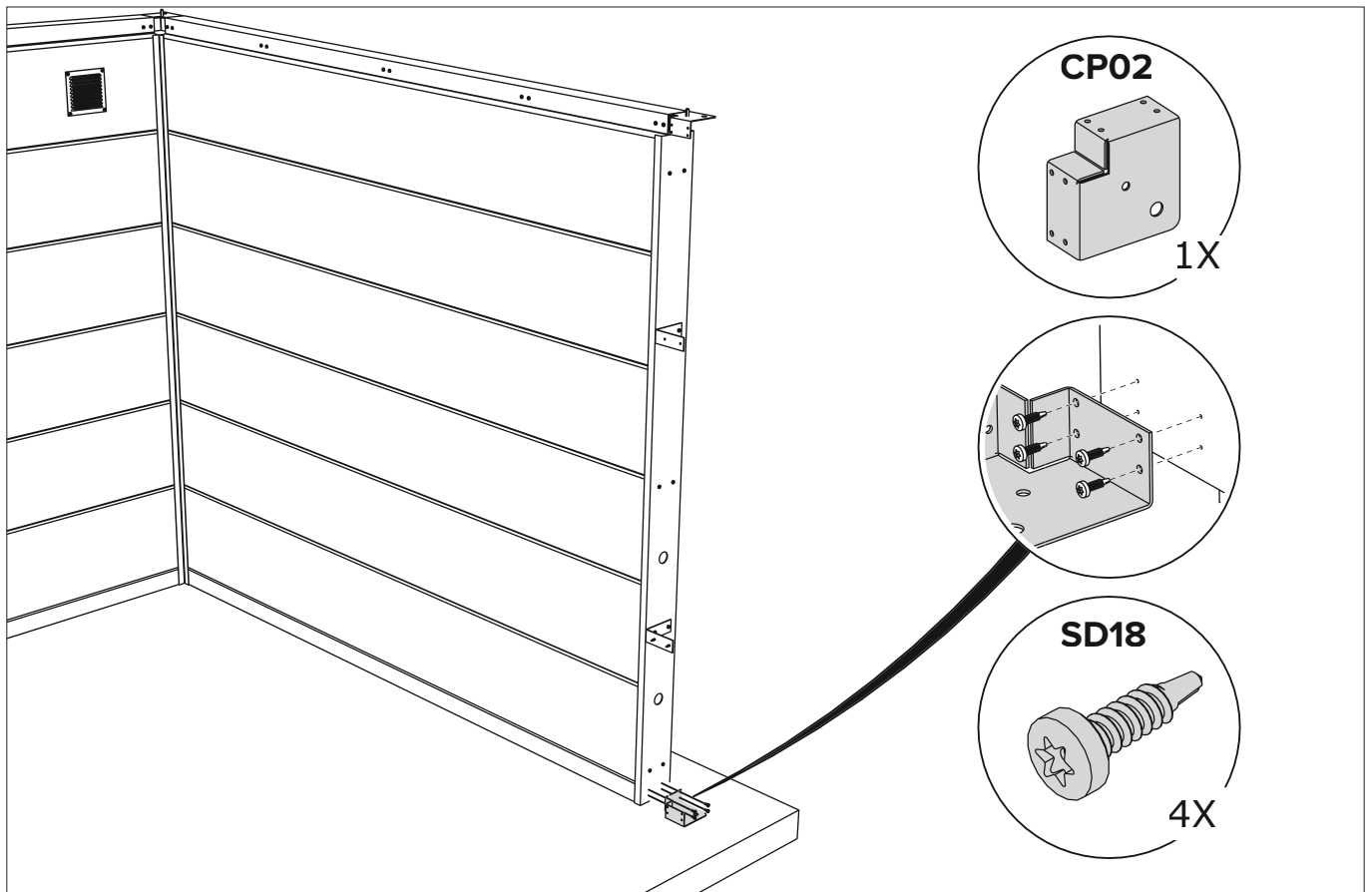

C + D Paroi / Wand / Wall / Wand

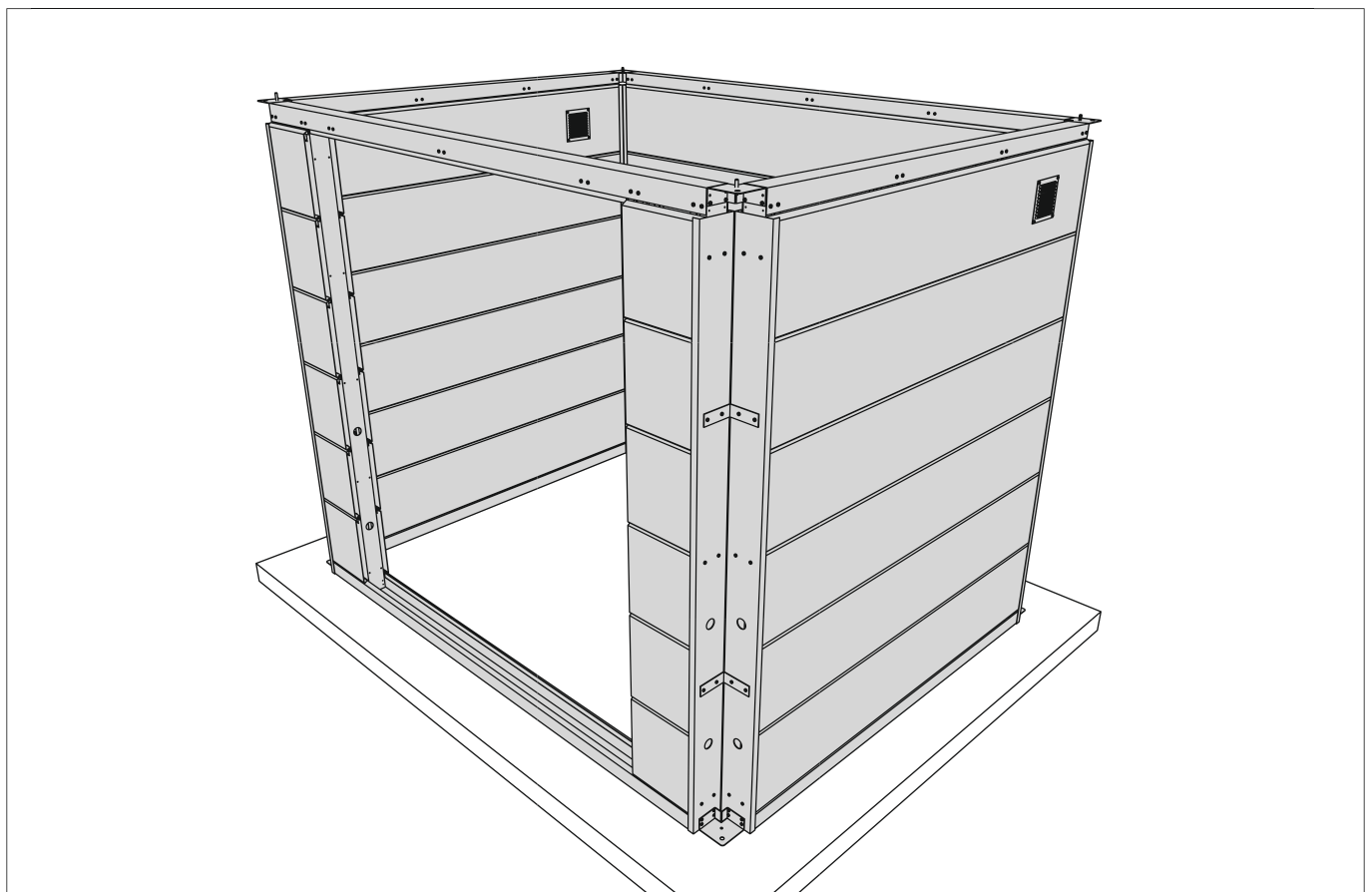

A + B + C + D Paroi / Wand / Wall / Wand

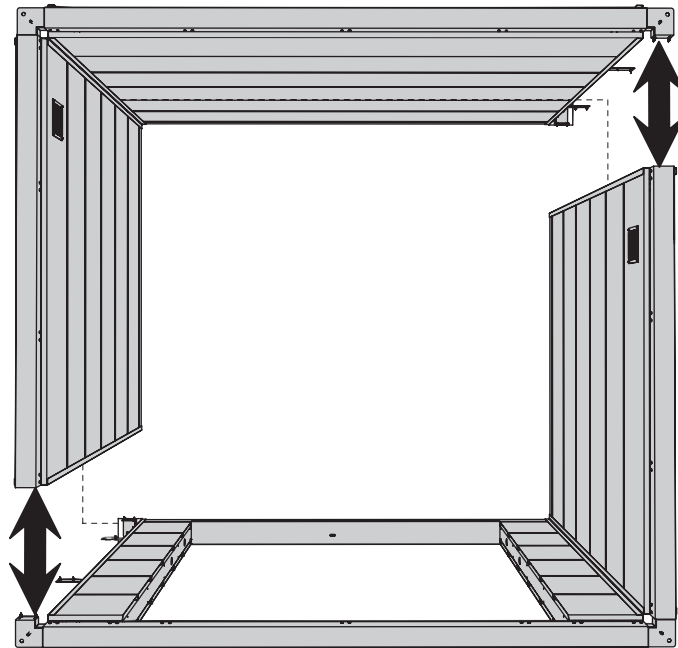

A+B+C+D Paroi / Wand / Wall / Wand

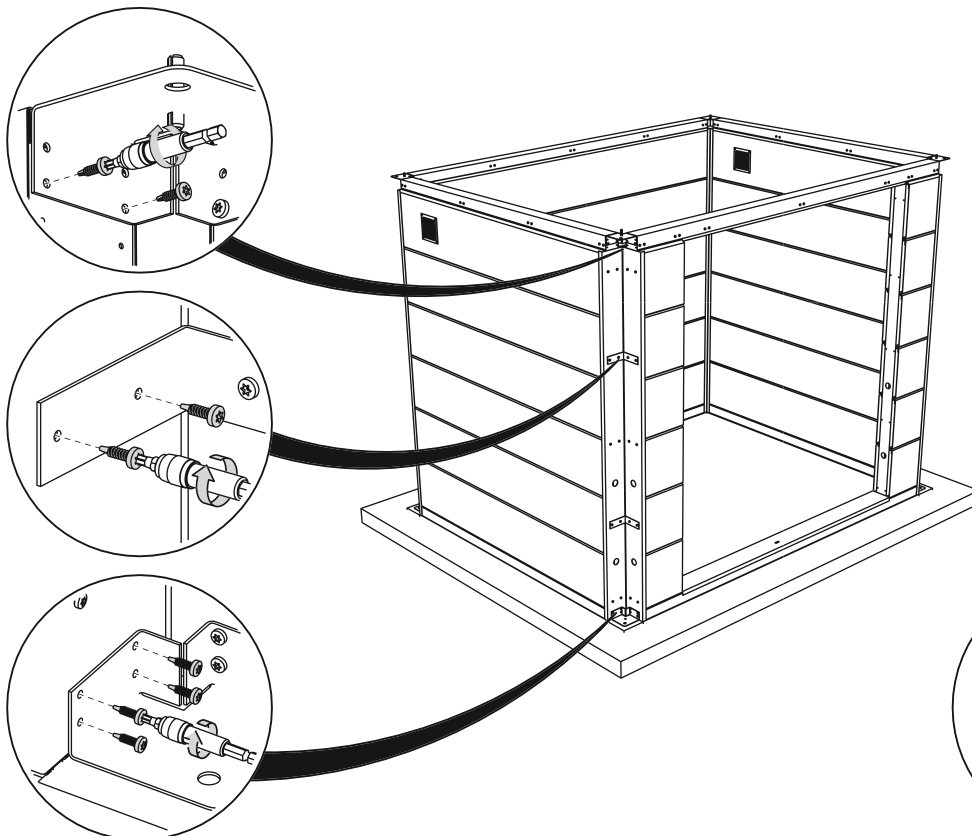

A+B+C+D Paroi / Wand / Wall / Wand

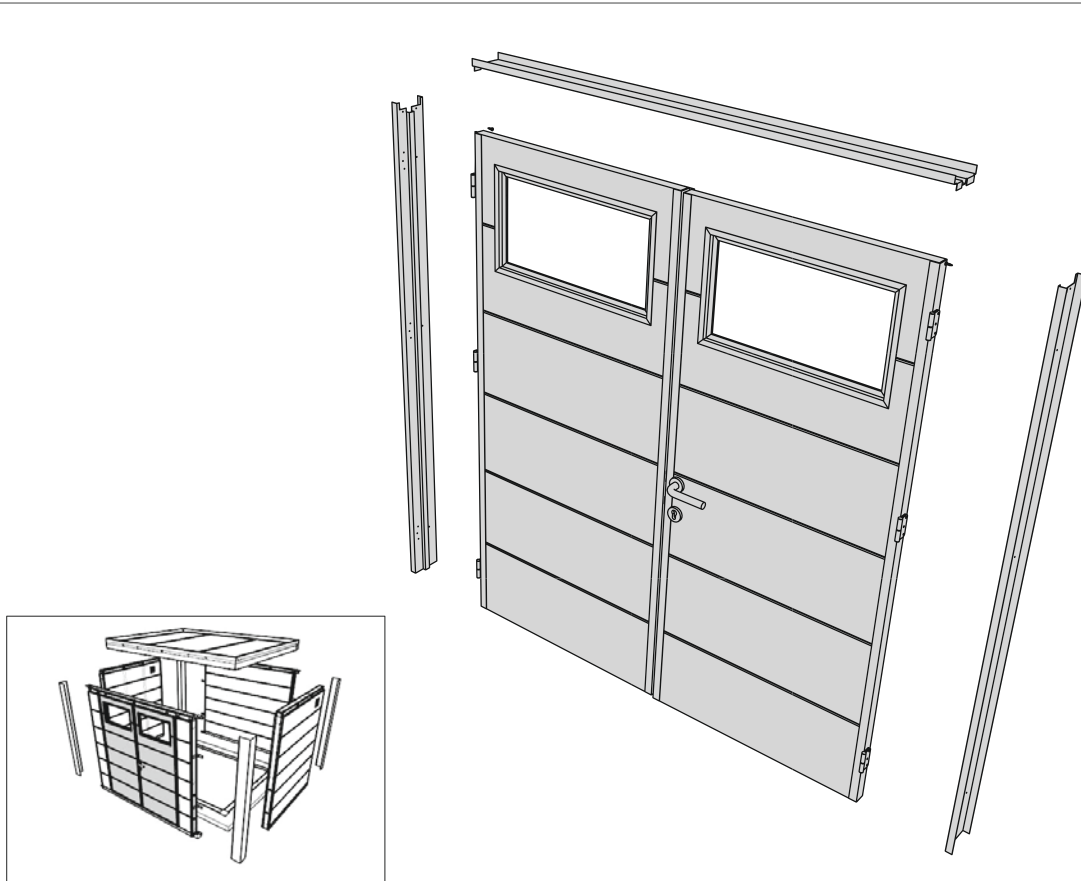

Porte / Deur / Door / Tür

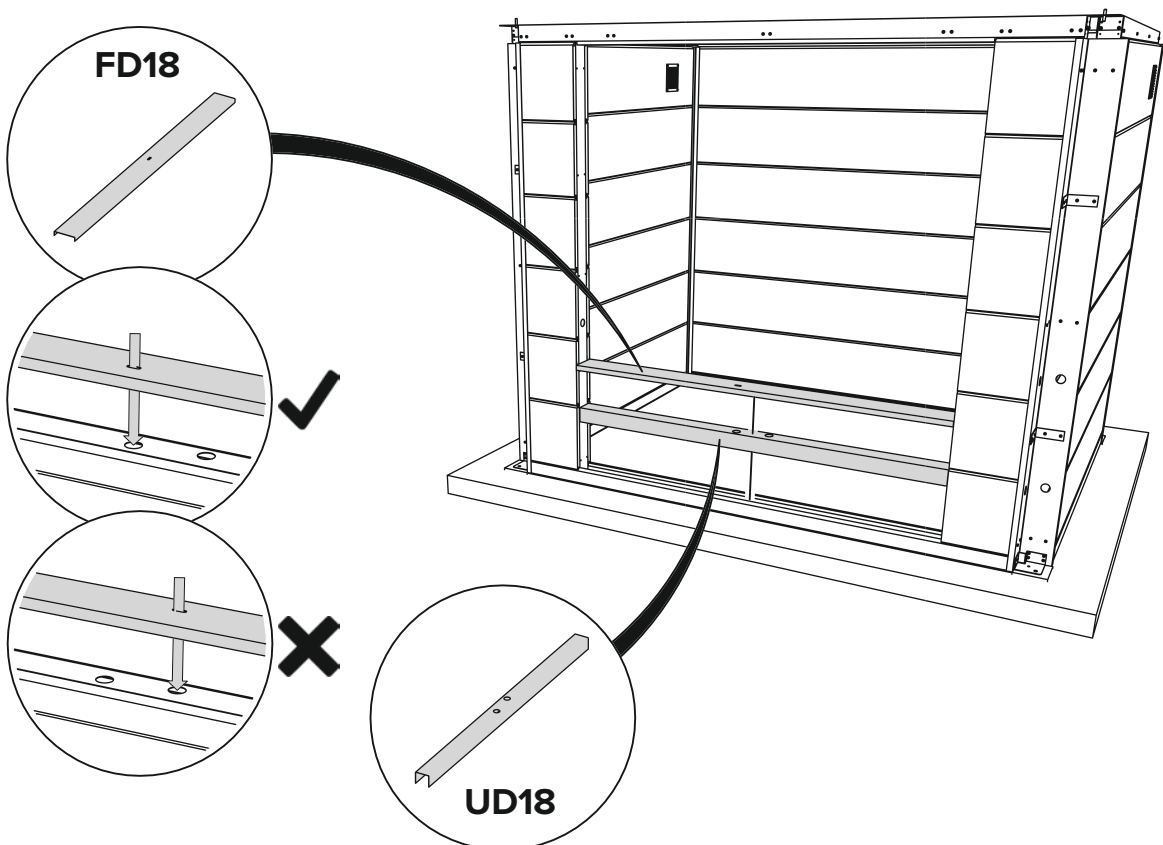

Porte / Deur / Door / Tür

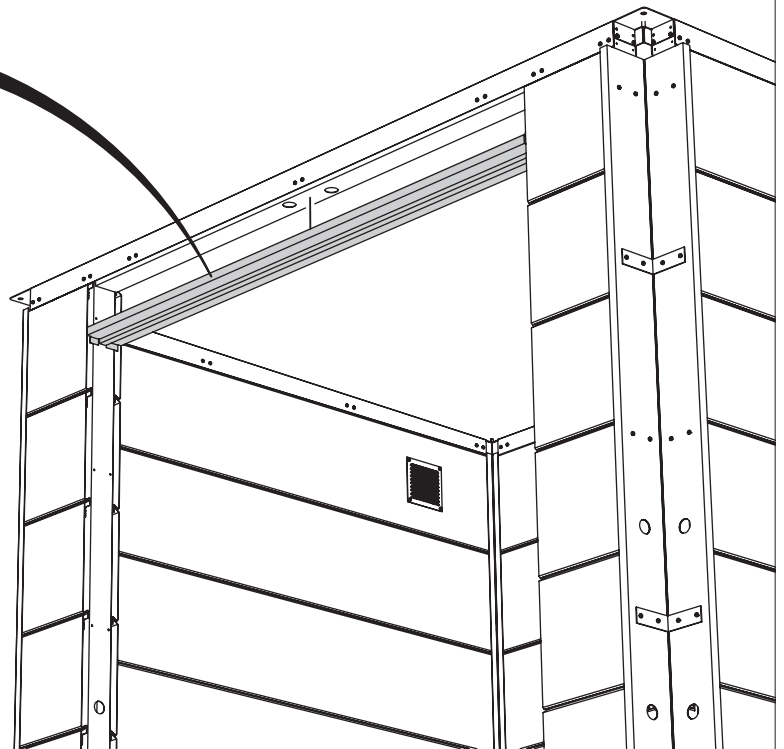
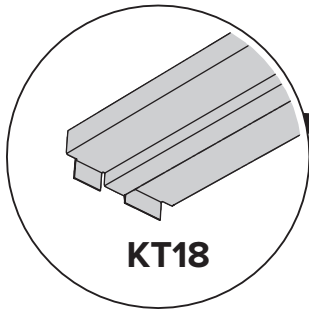

Porte / Deur / Door / Tür

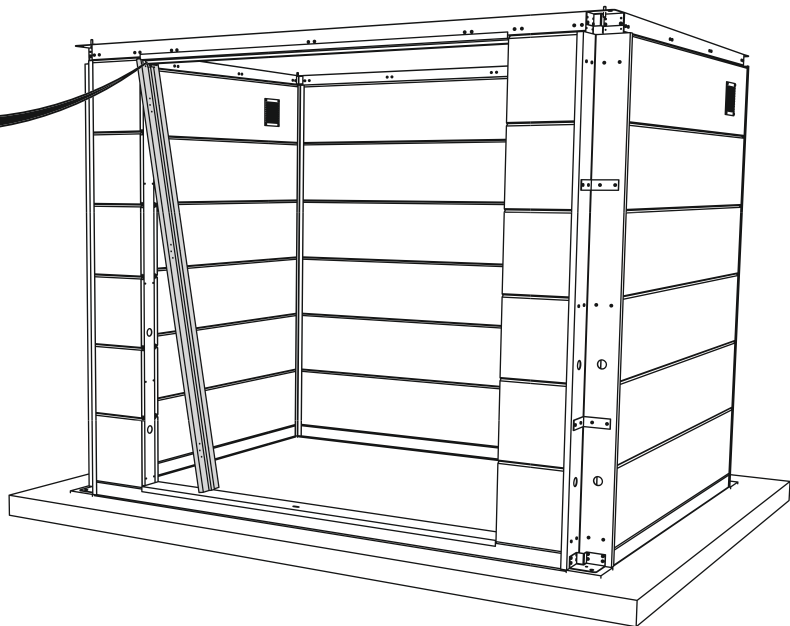
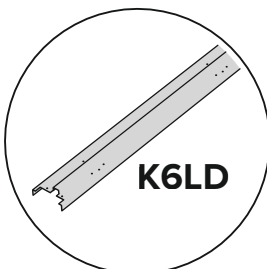
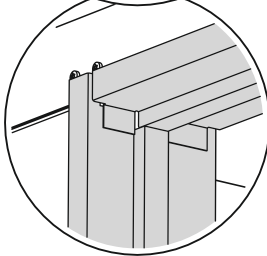
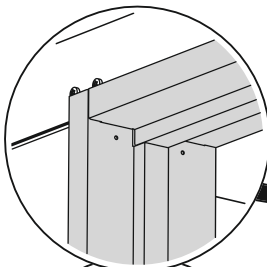

Porte / Deur / Door / Tür

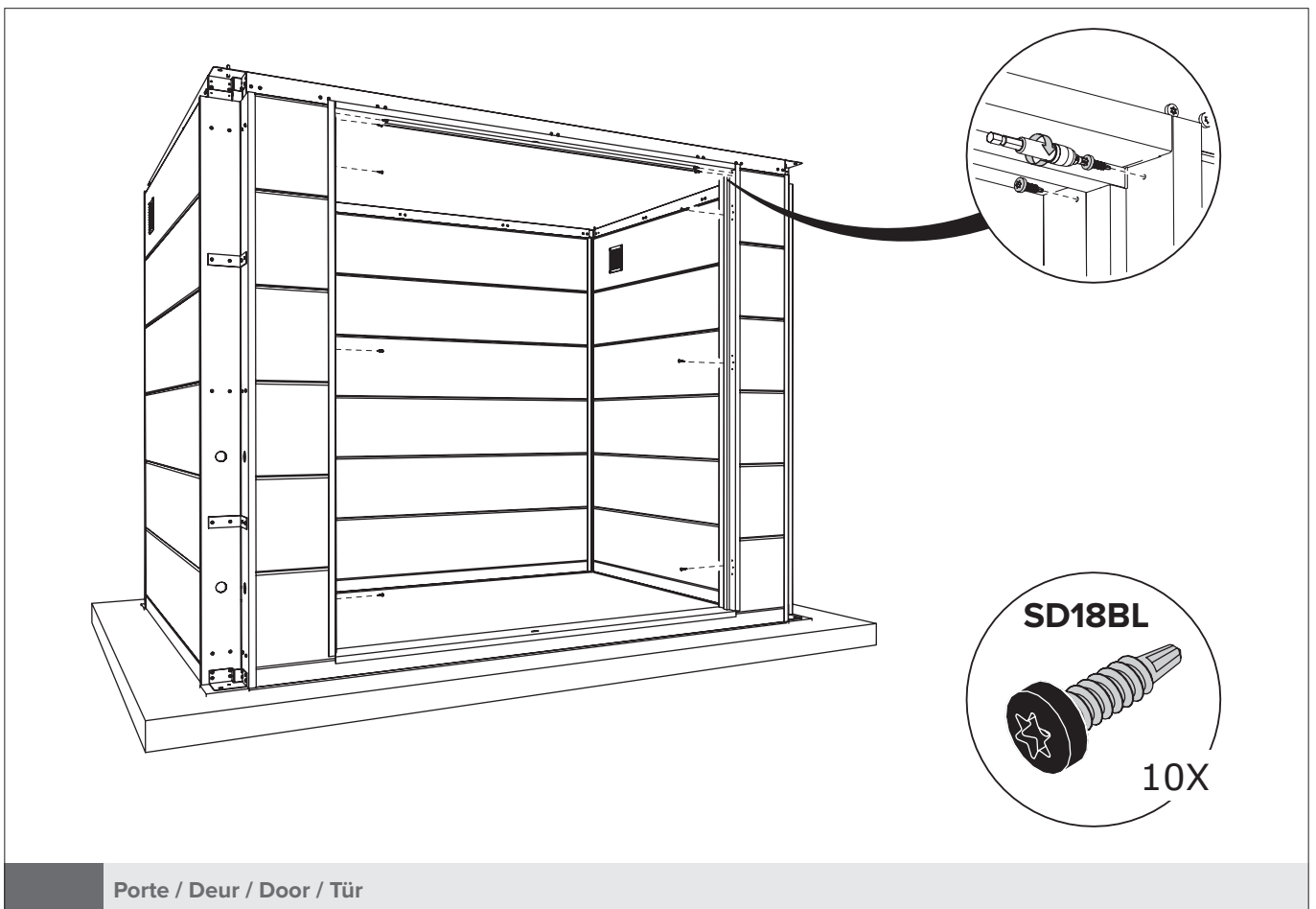
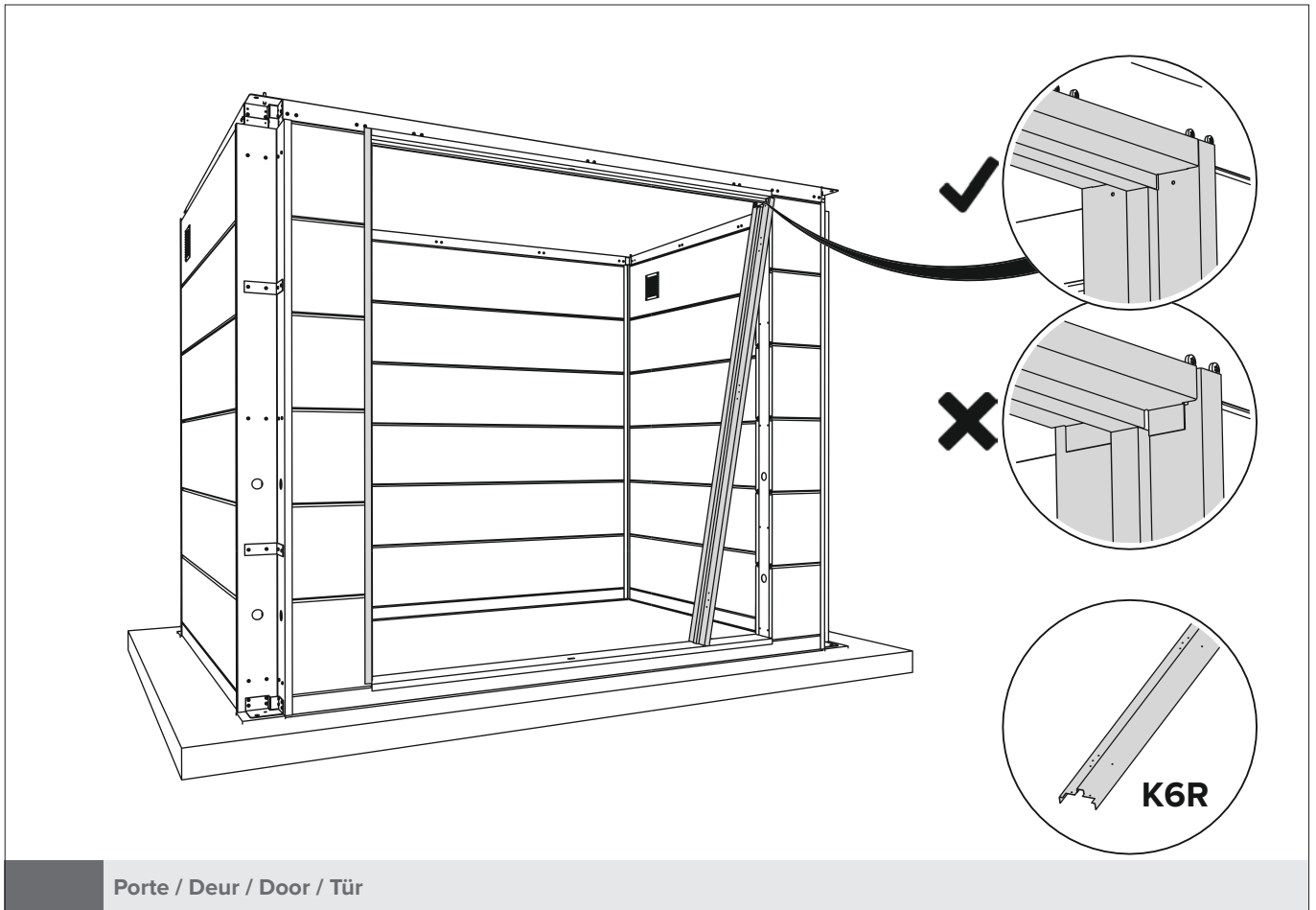

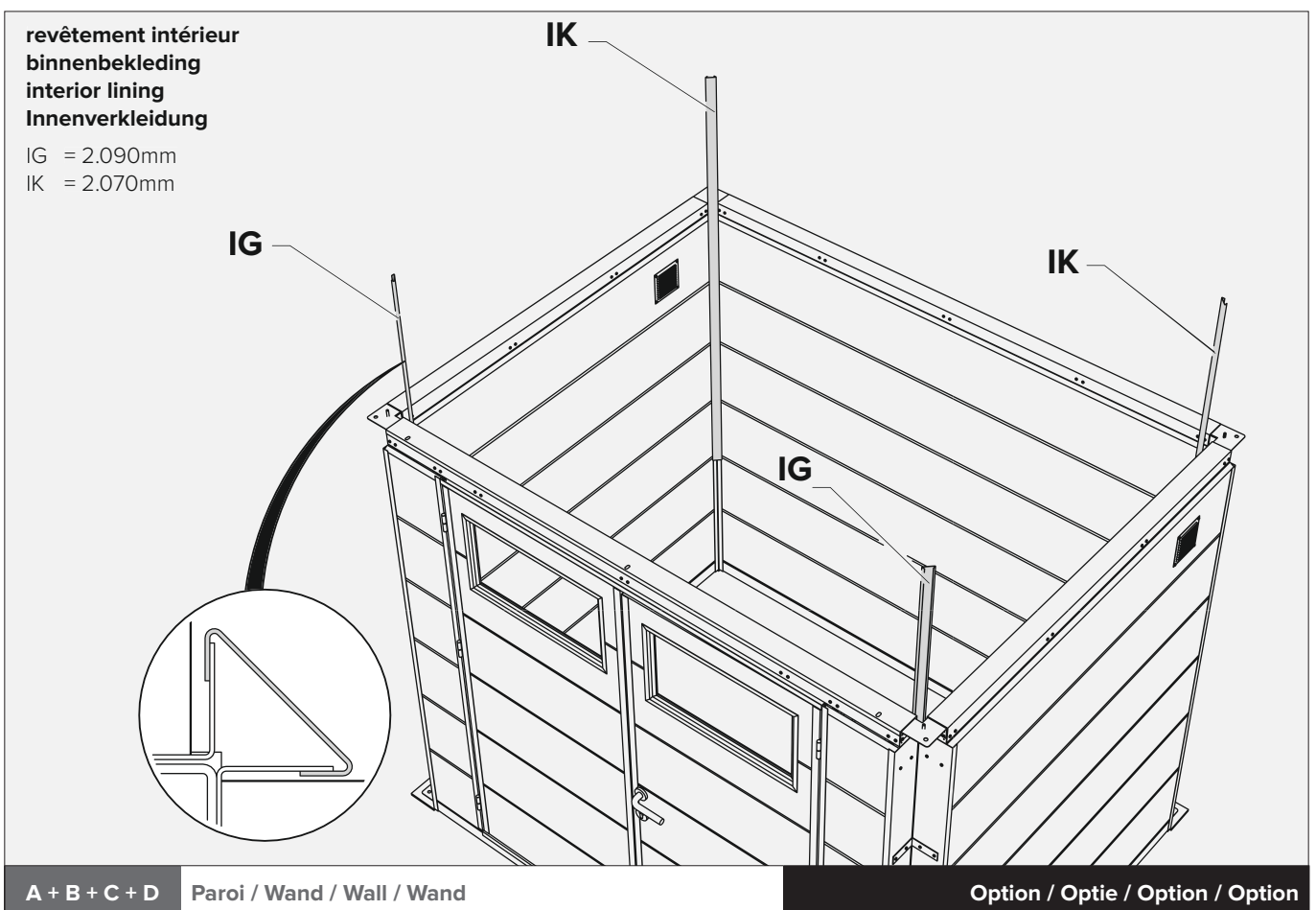
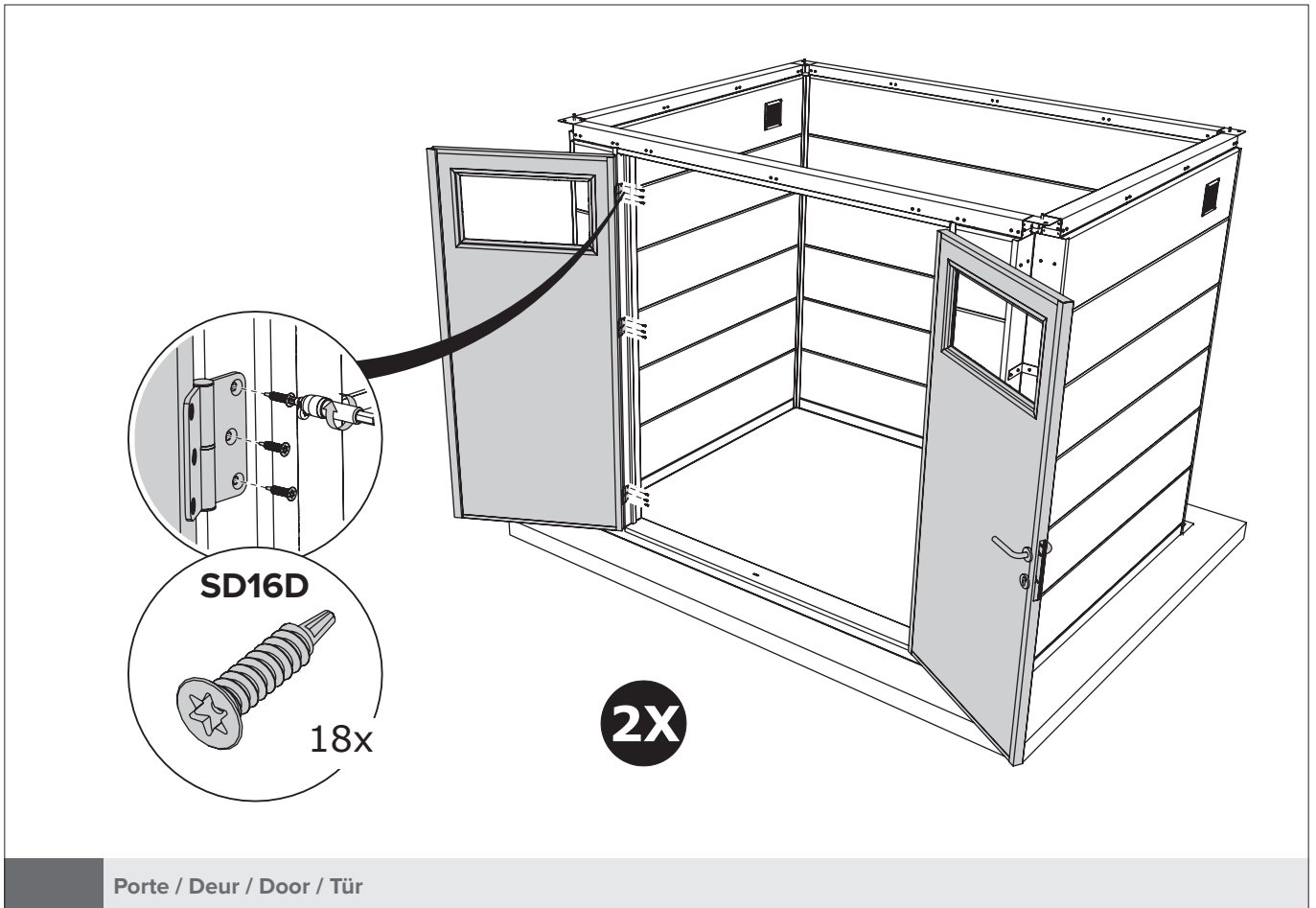

revêtement intérieur
 binnenbekleding
 interior lining
 Innenverkleidung

X21D

X27C

X27A

X21B

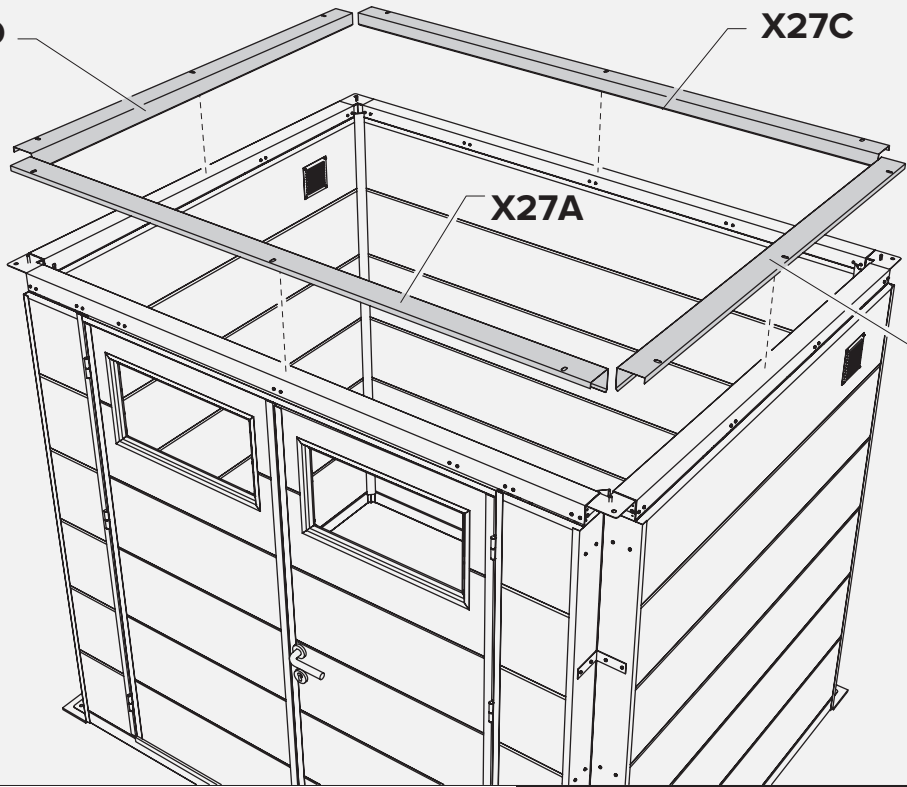

A + B + C + D Paroi / Wand / Wall / Wand

Option / Optie / Option / Option

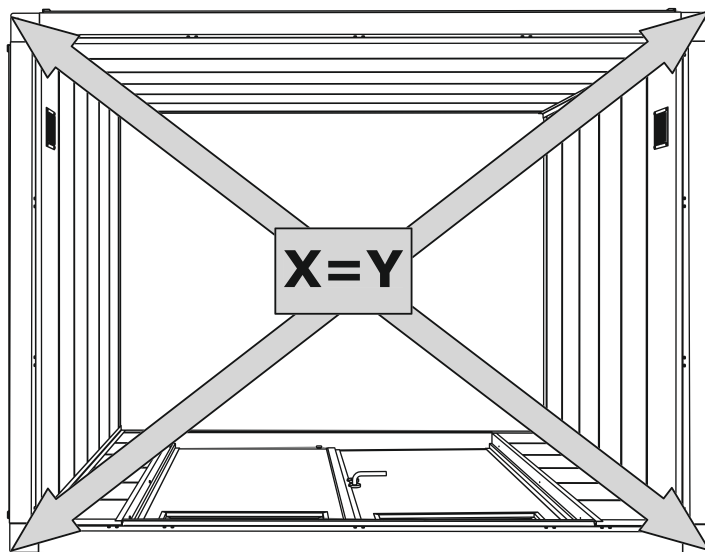
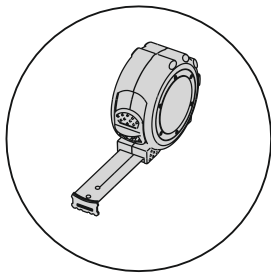

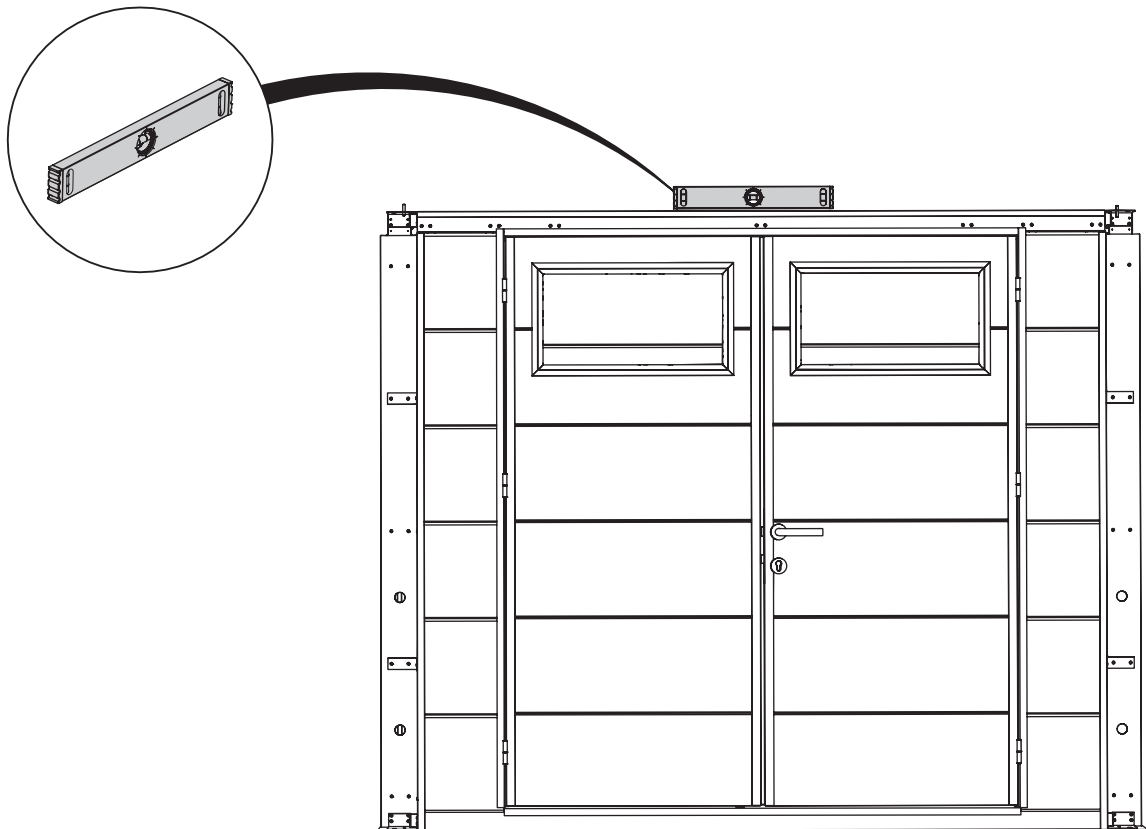
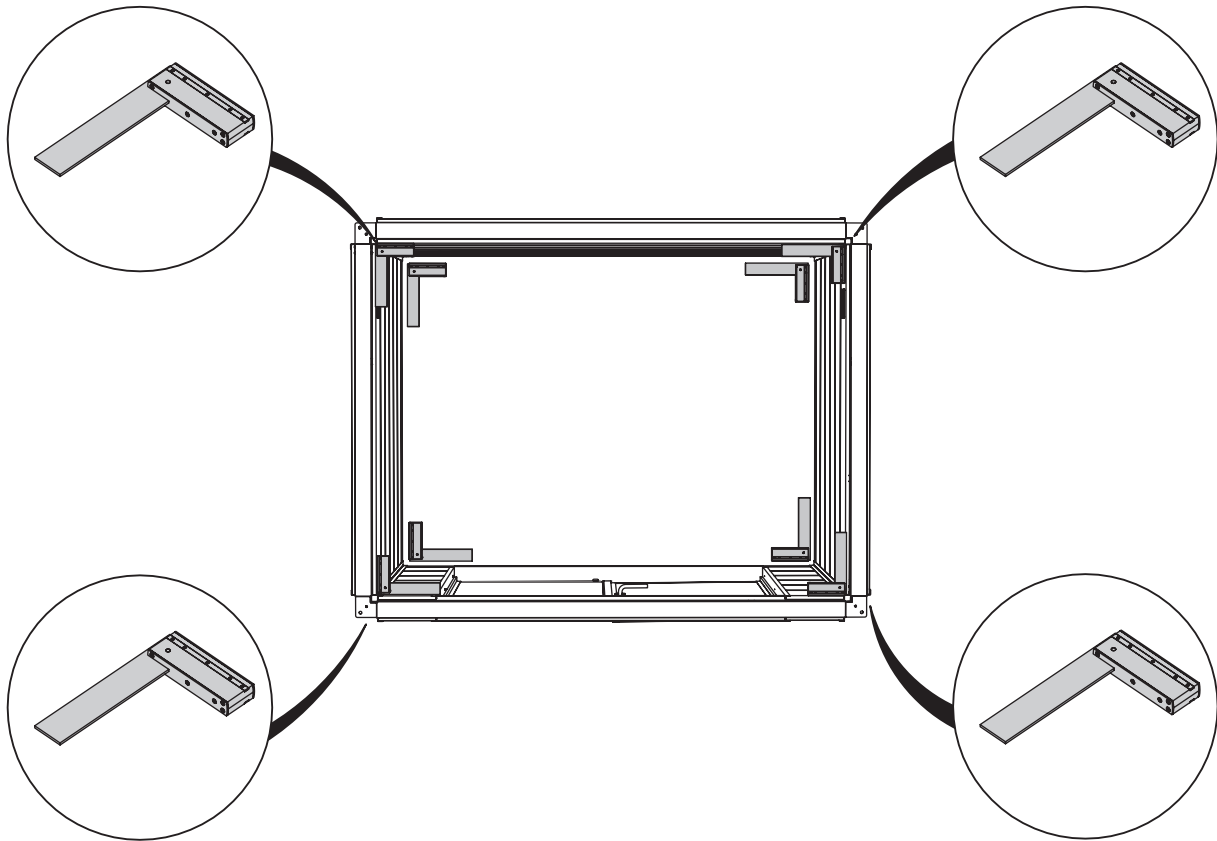

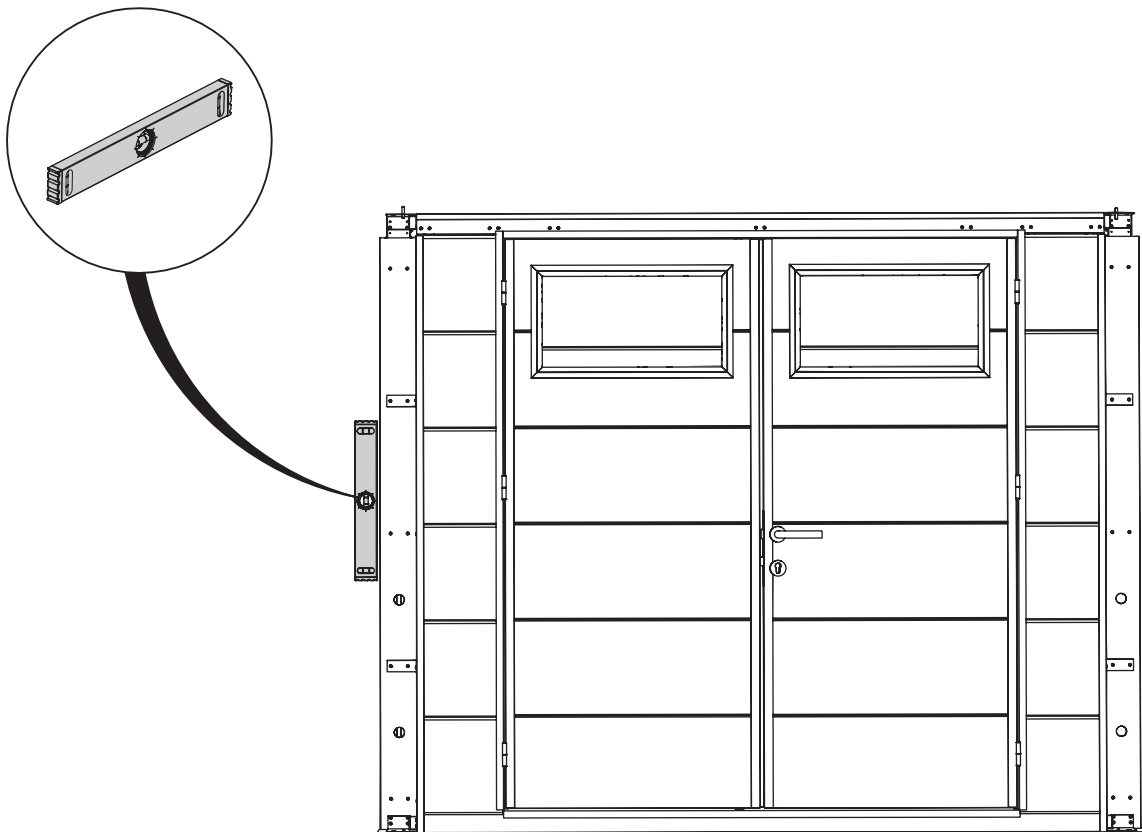
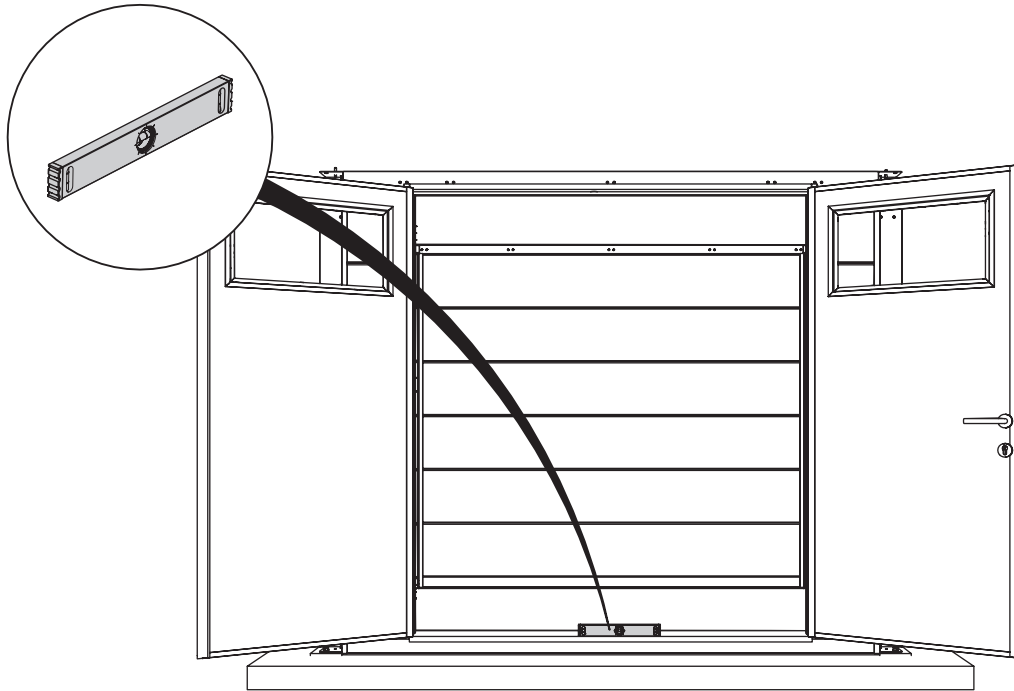

Retirer la bande / Tape verwijderen / Remove tape / Klebeband entfernen

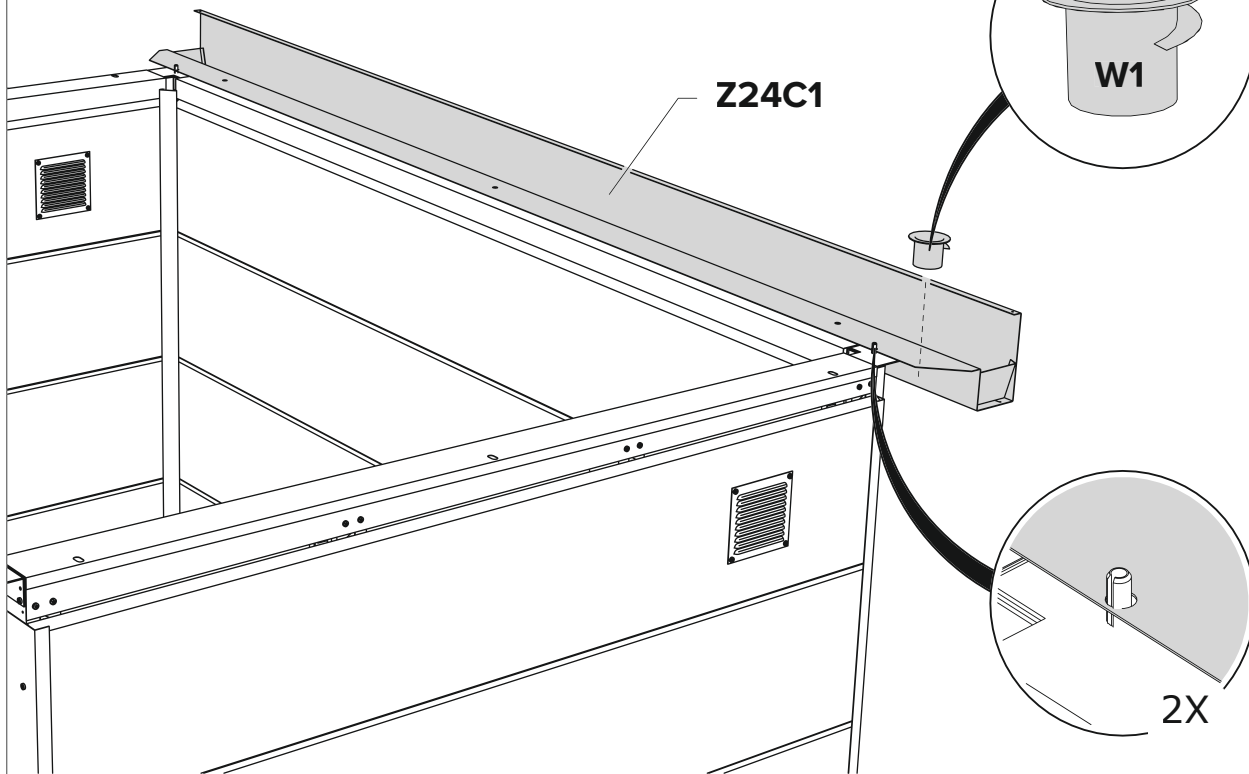

Toit / Dak / Roof / Dach

Retirer le film / Verwijder folie / Remove foil / Folie entfernen

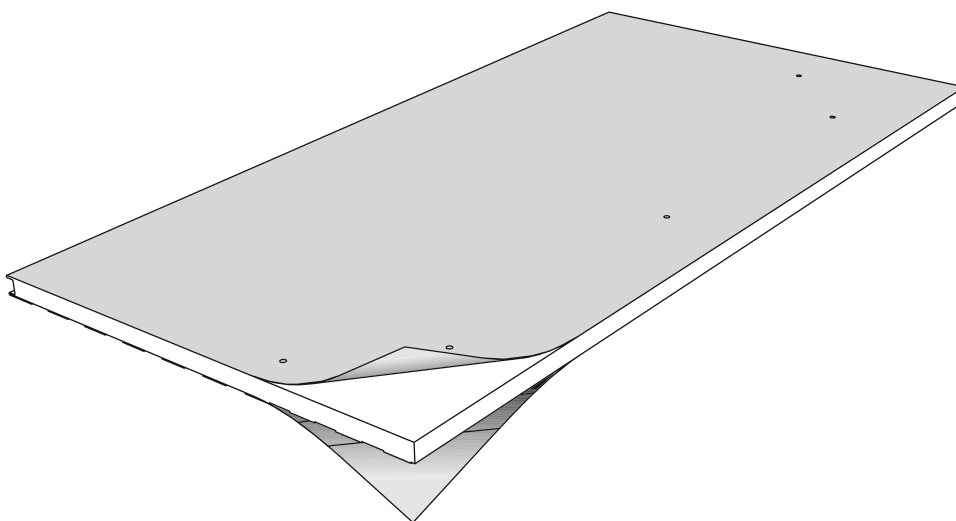

Toit / Dak / Roof / Dach

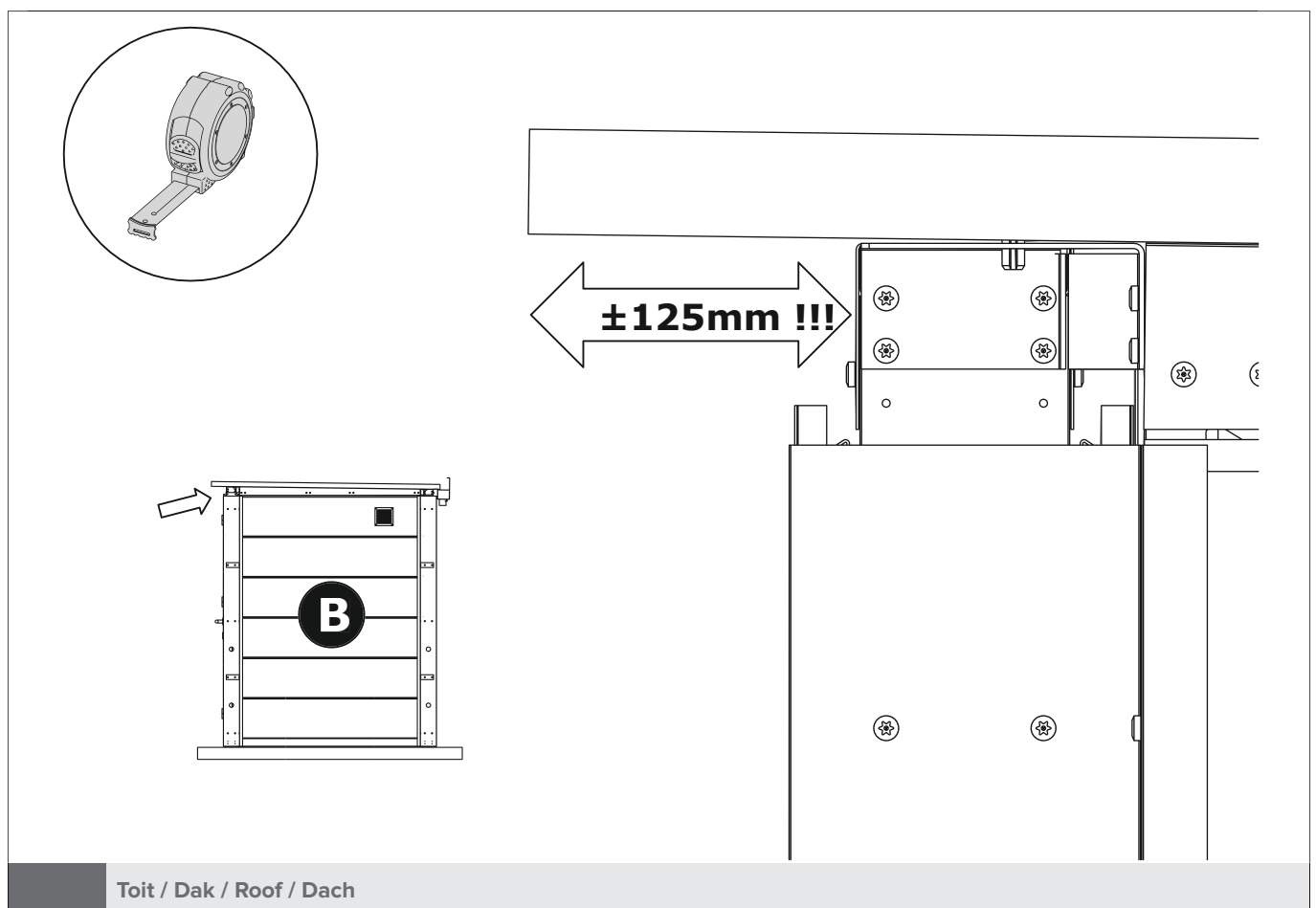
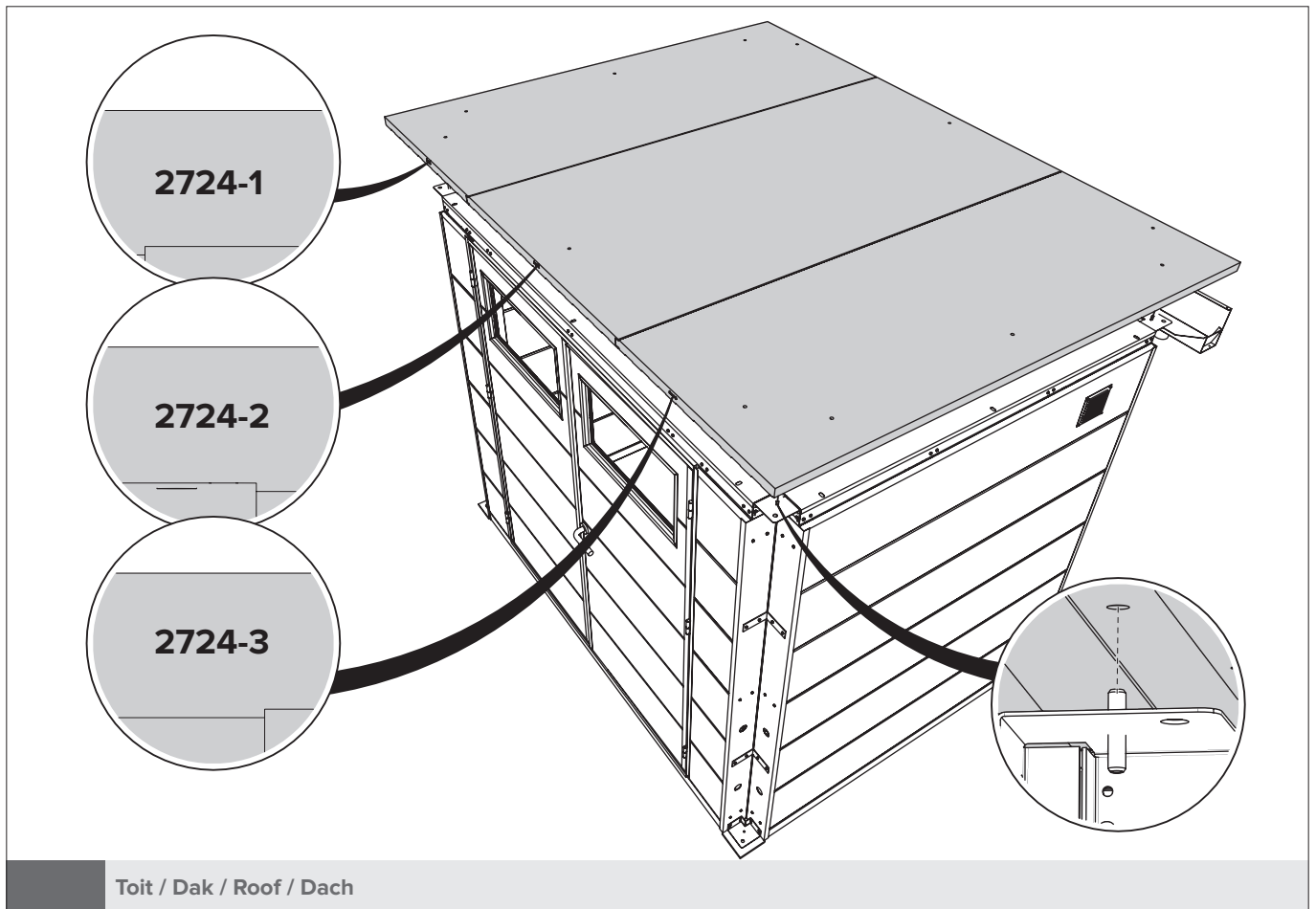

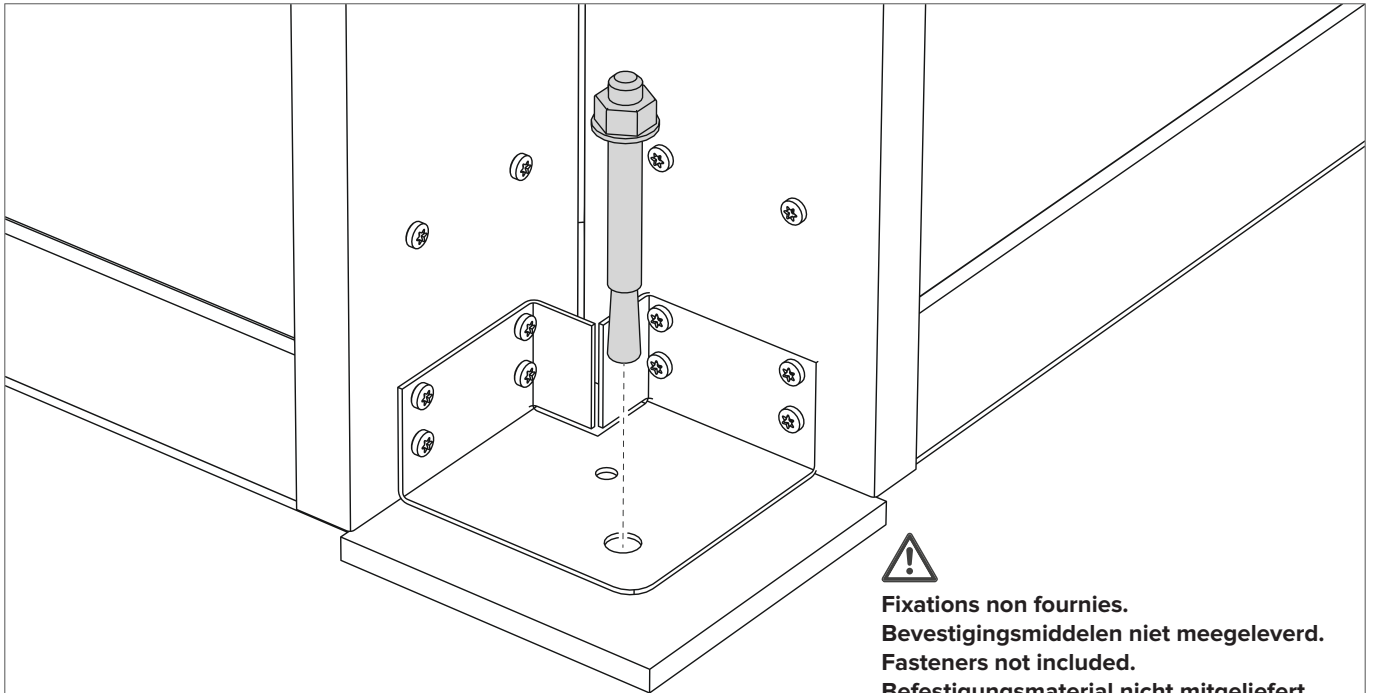

Exemple donné pour un sous-sol en béton. Fixer l'abri de jardin dans les règles de l'art.
 Voorbeeld is voor beton-ondergrond. Tuinhuisje fixeren volgens de regels van de kunst.
 Example is for concrete substrate. Fix the garden shed in accordance with good practise.
 Beispiel ist für Betonuntergrund. Fachgerechte Befestigung des Gartenhäuschens.

Ancrage / Verankering / Anchoring / Verankerung

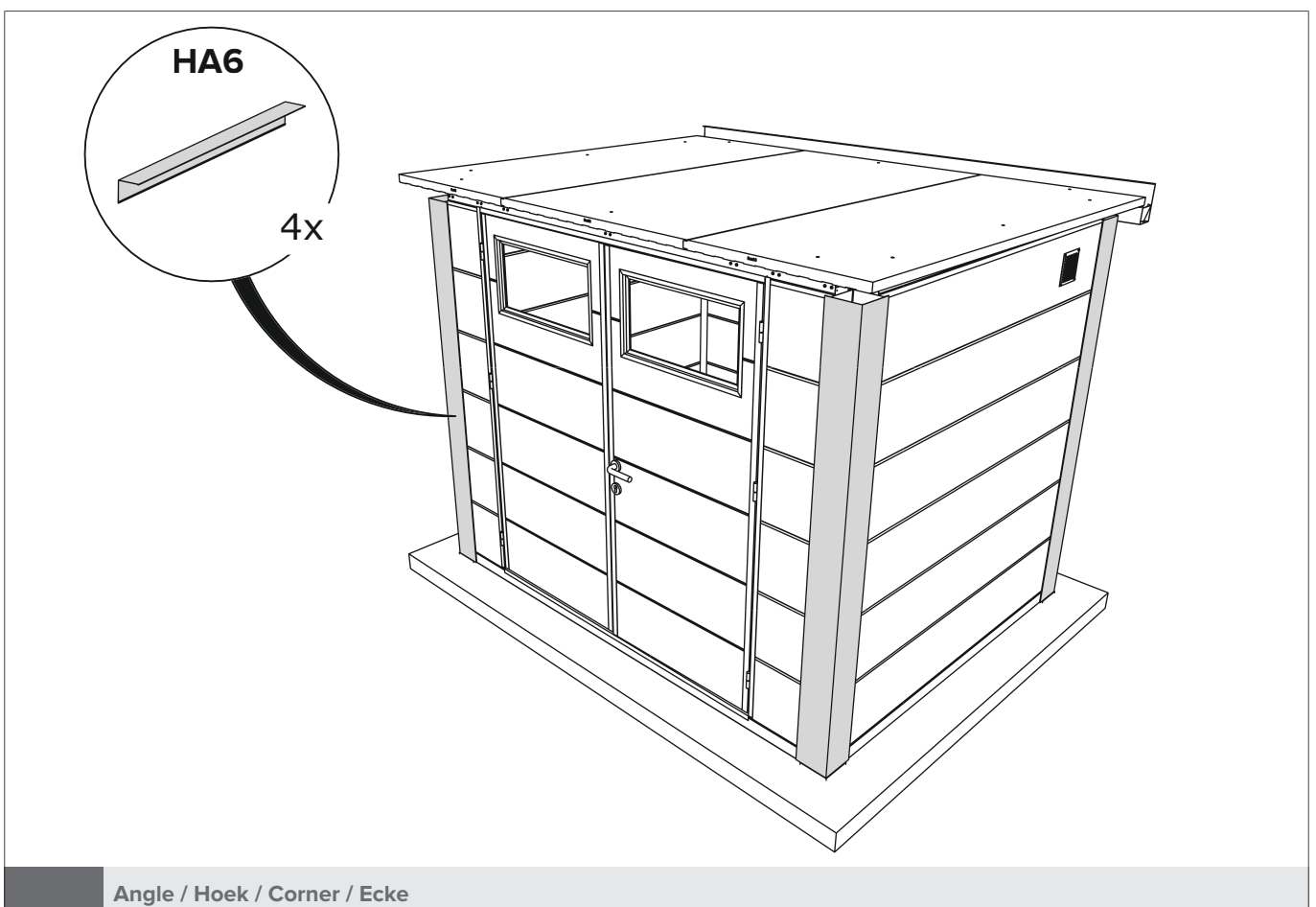

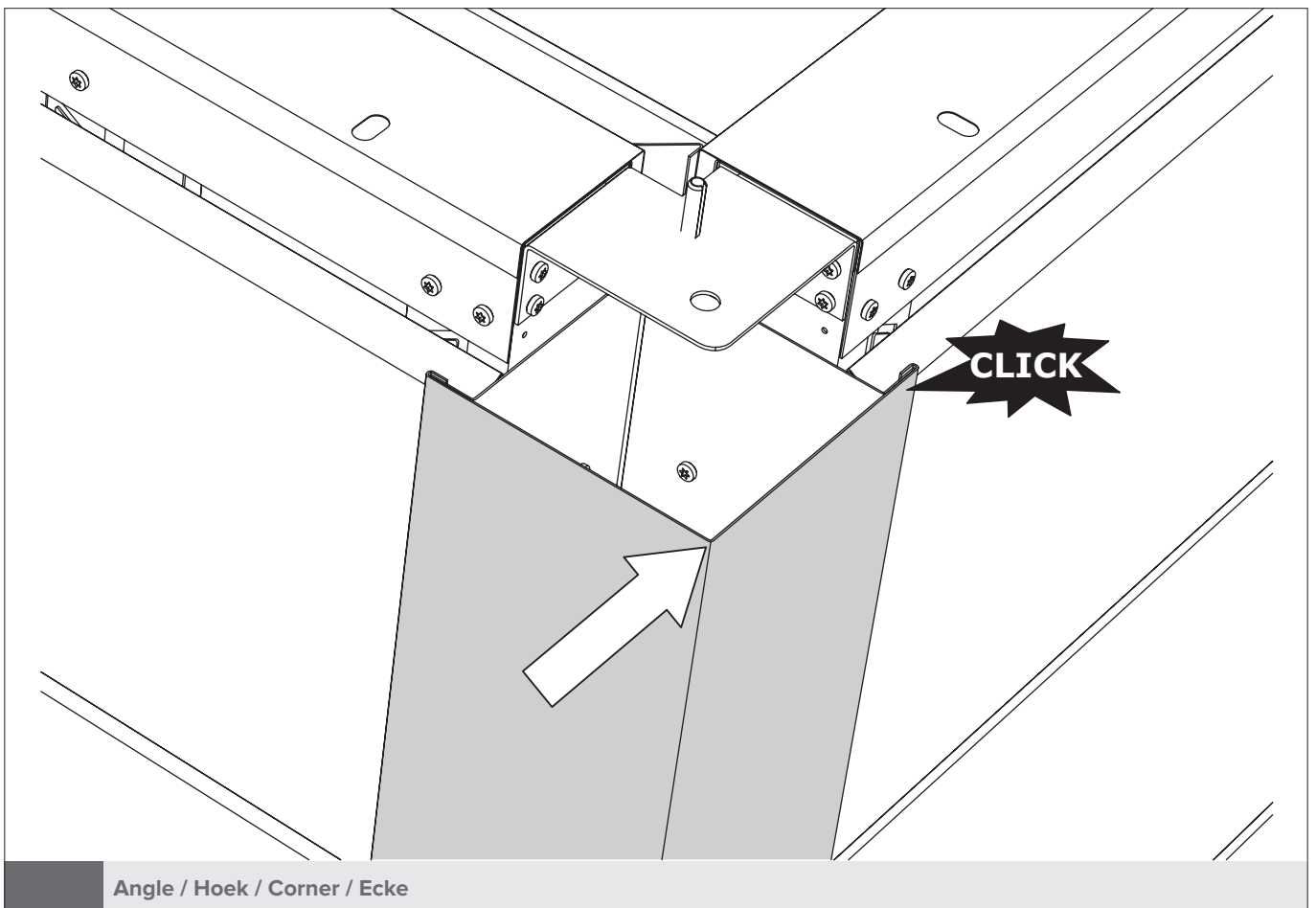
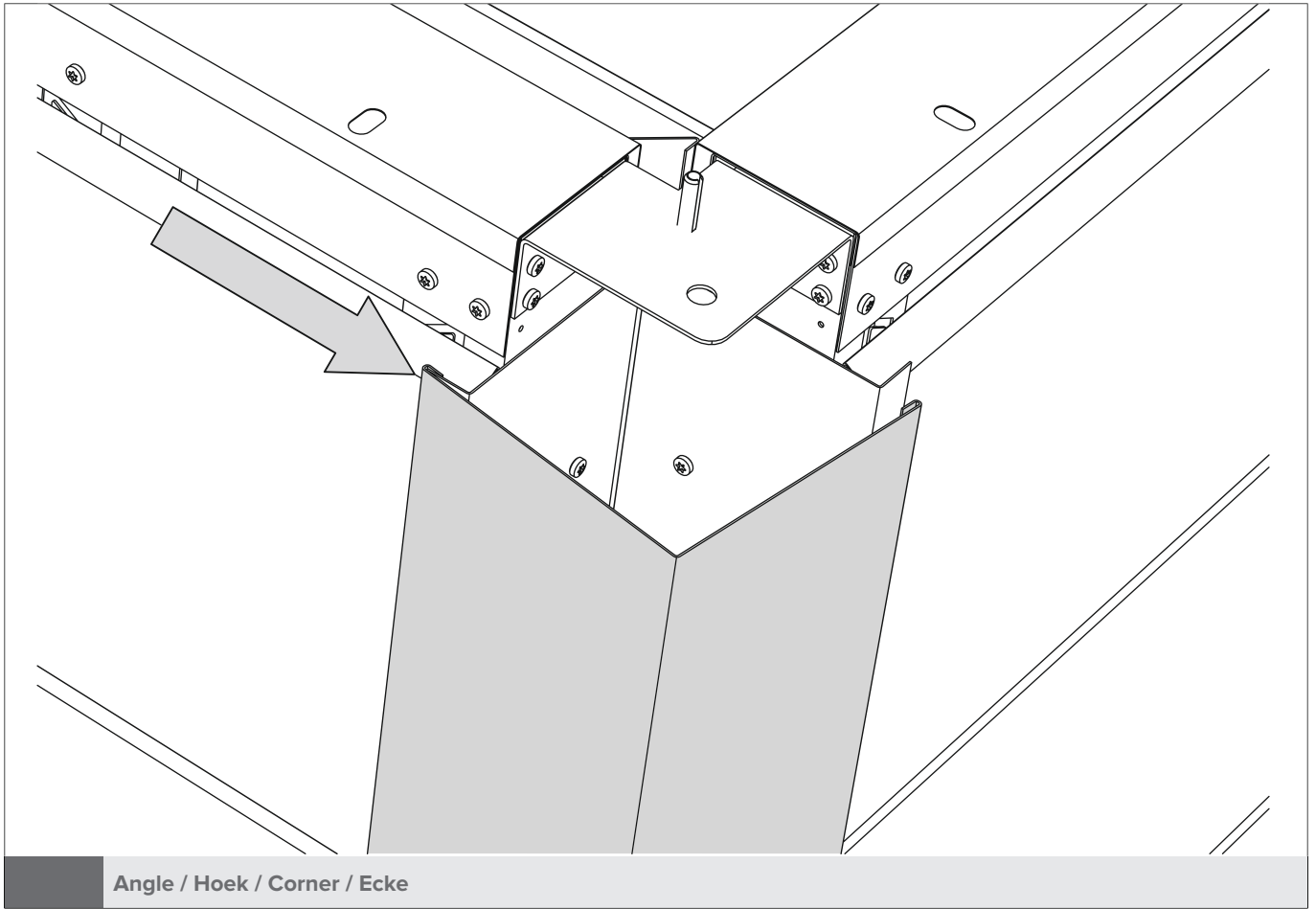

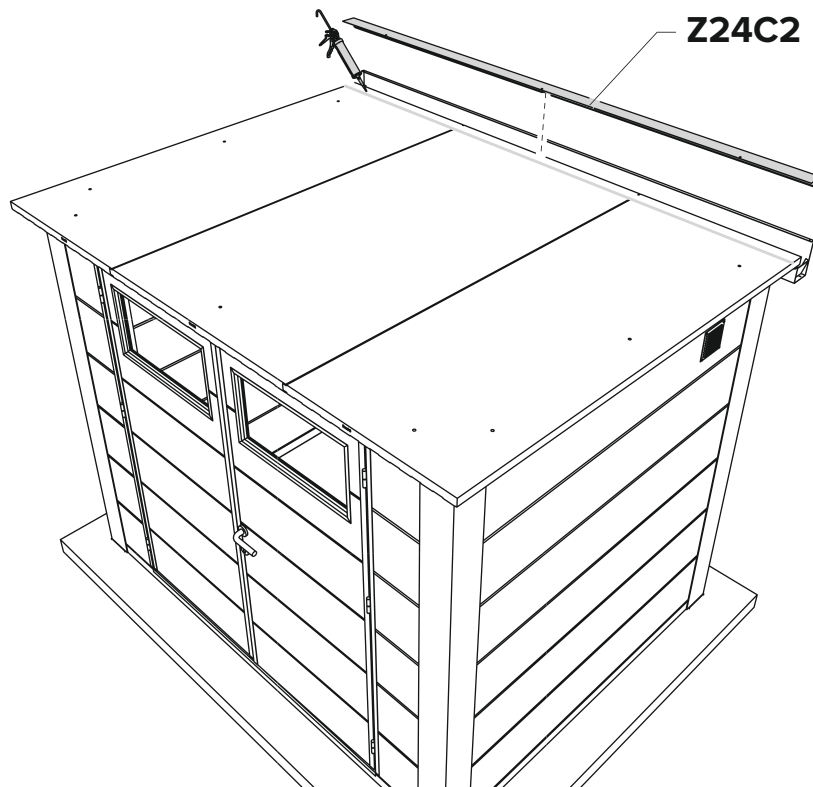

Toit / Dak / Roof / Dach

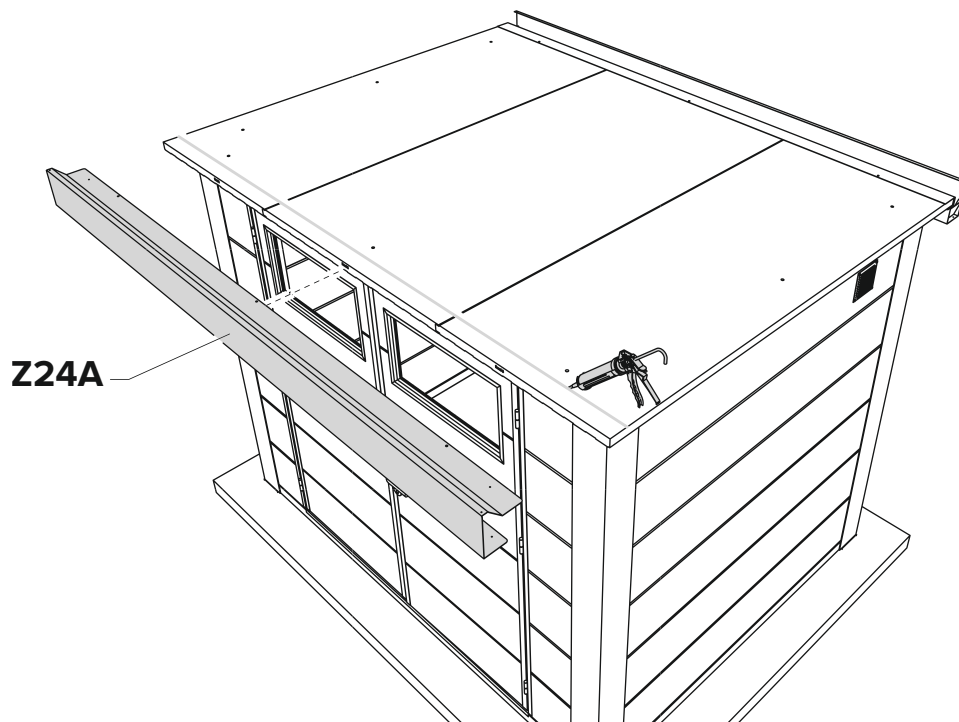

Toit / Dak / Roof / Dach

Z21D

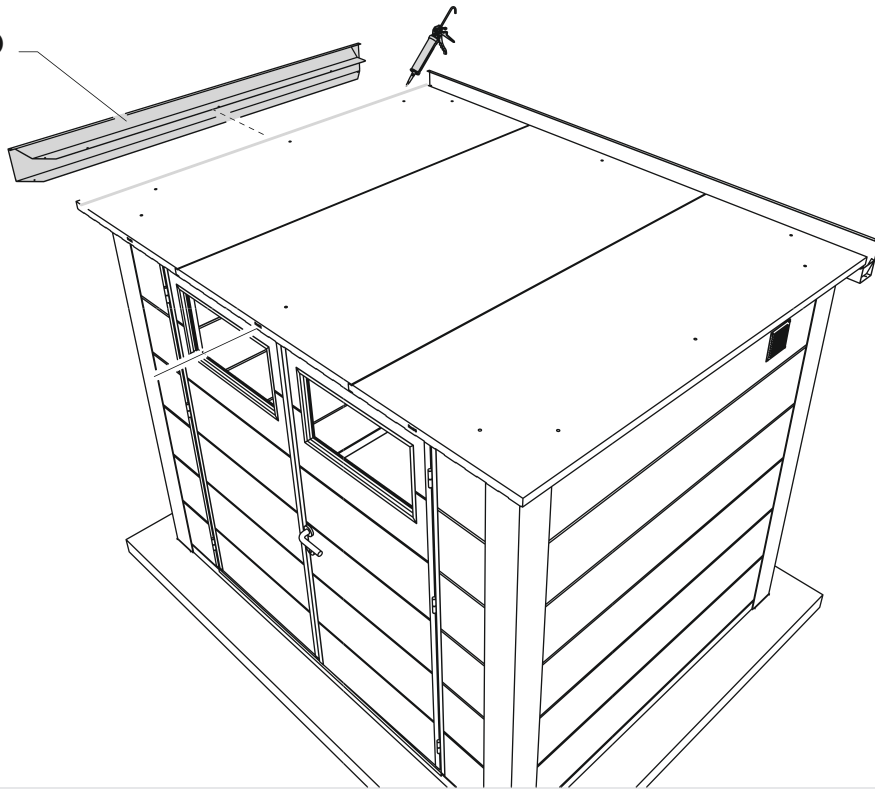

Toit / Dak / Roof / Dach

Z21B

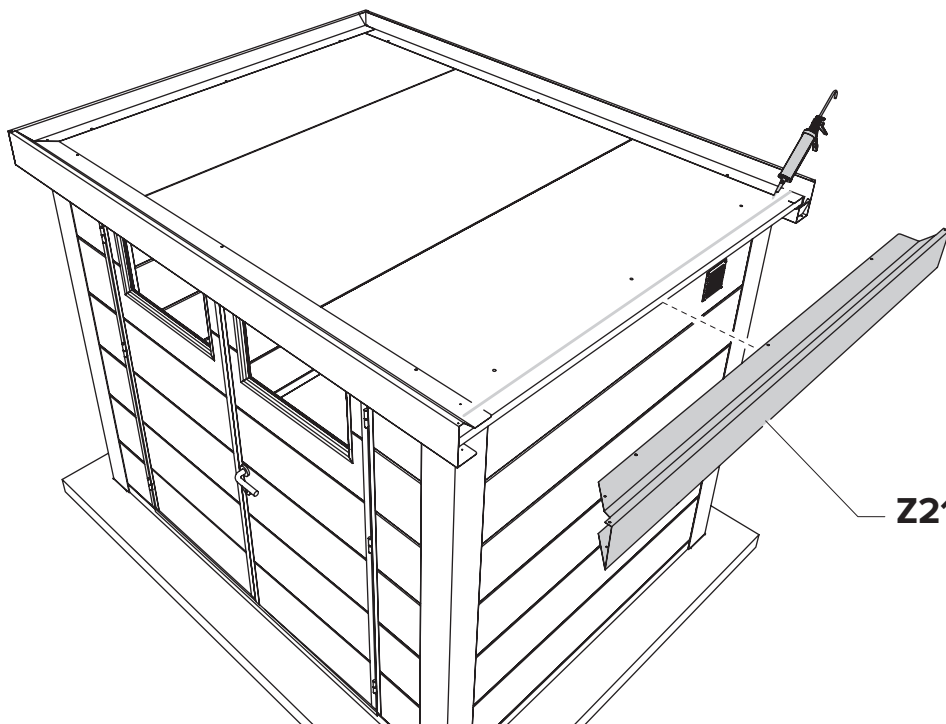

Toit / Dak / Roof / Dach

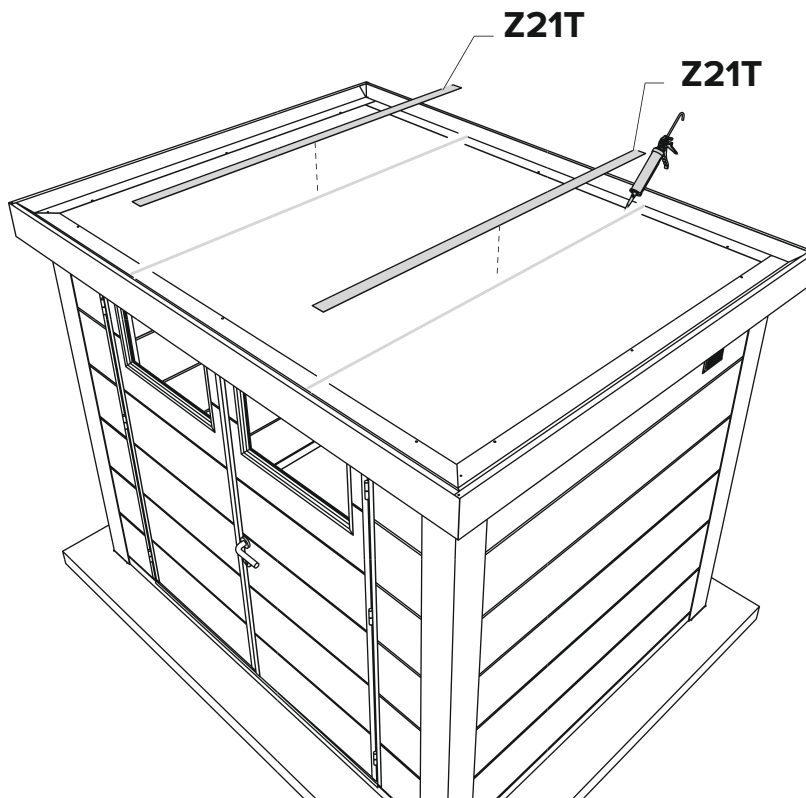

Toit / Dak / Roof / Dach

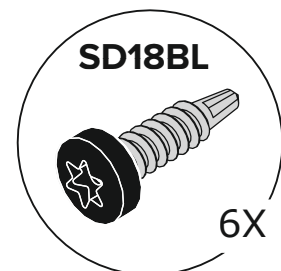
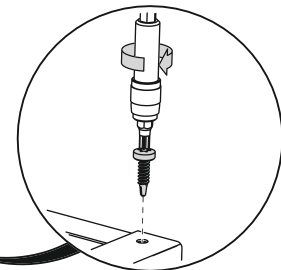
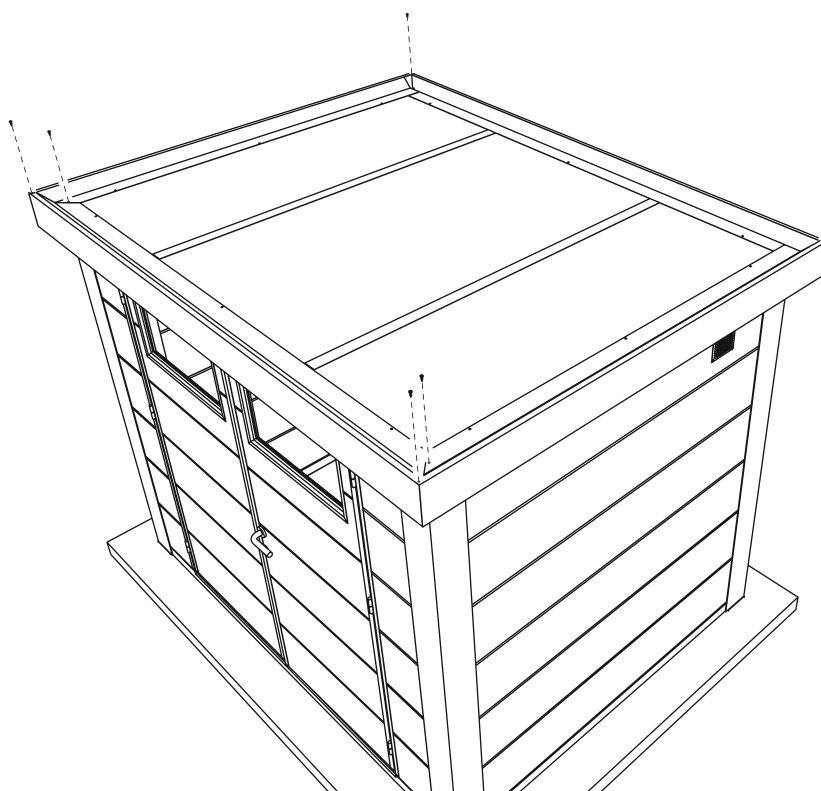

Toit / Dak / Roof / Dach

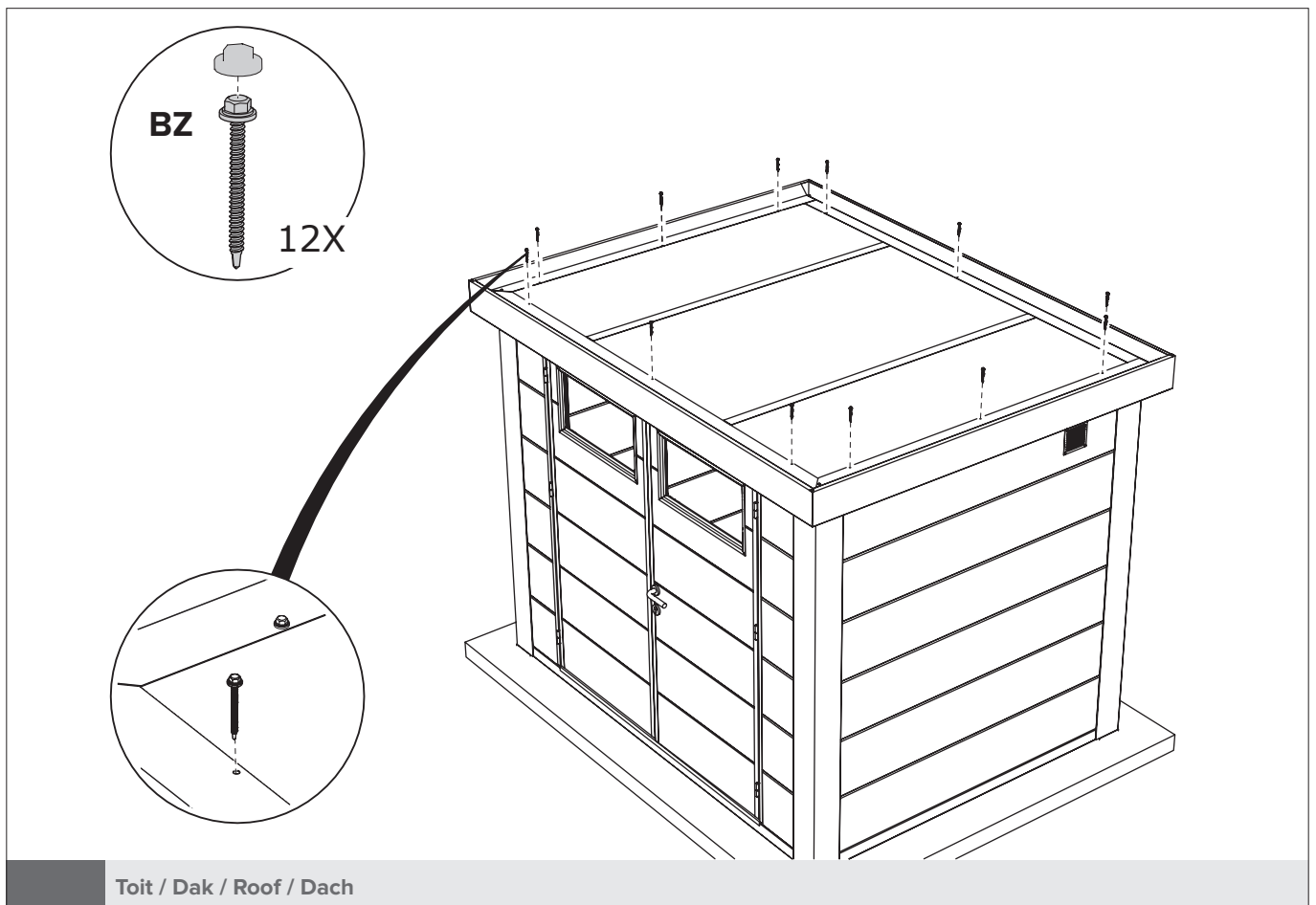
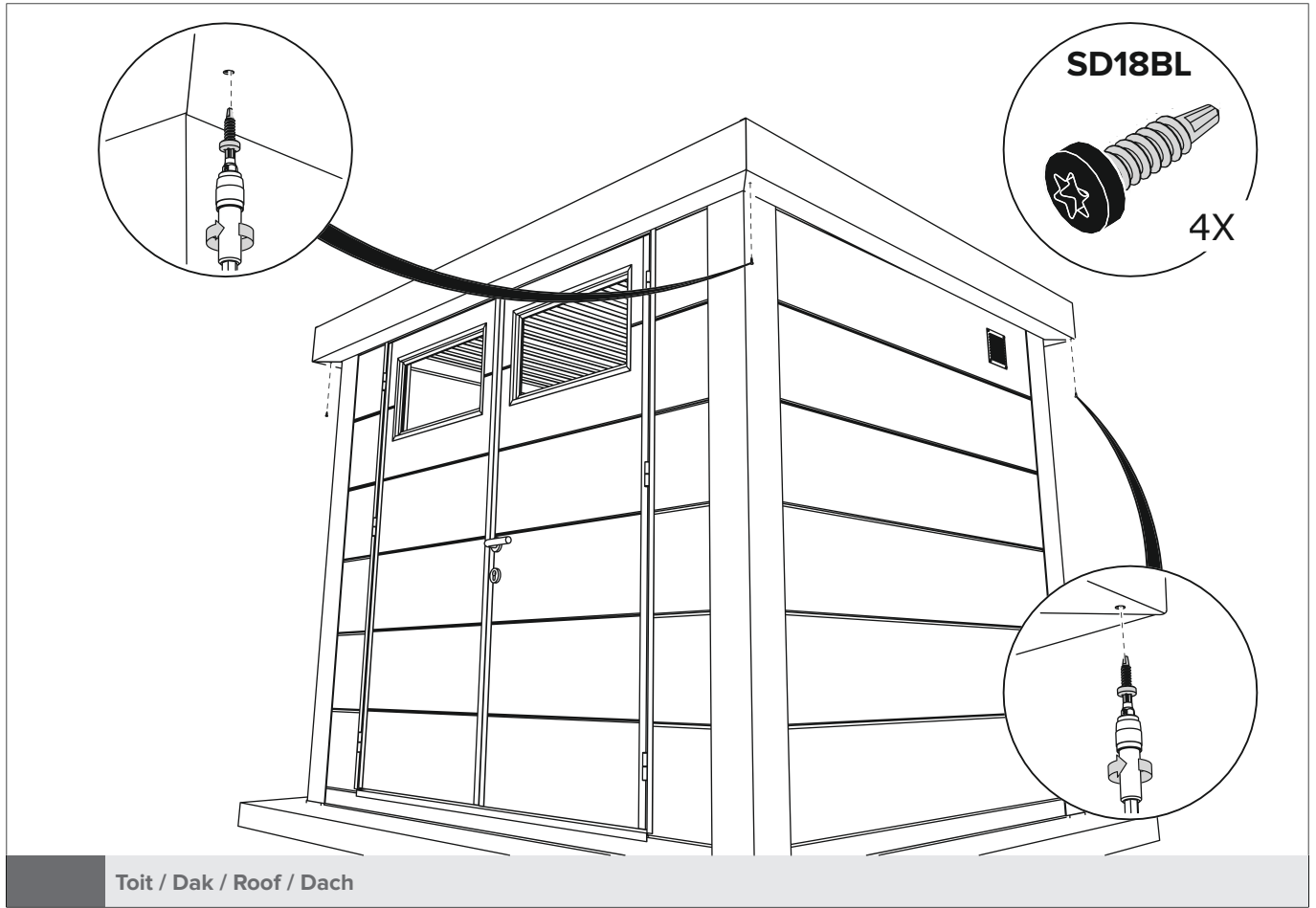

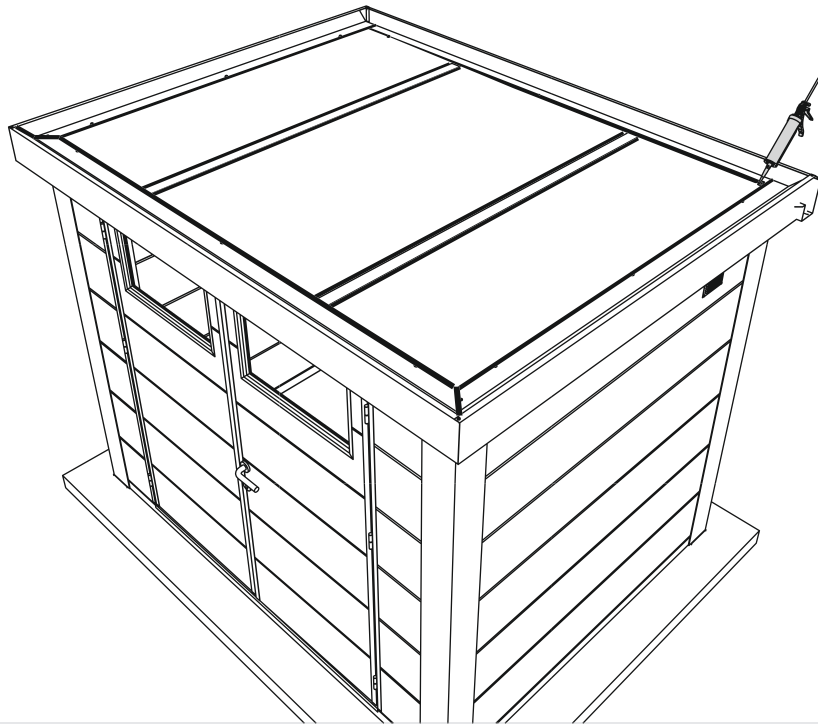

Toit / Dak / Roof / Dach

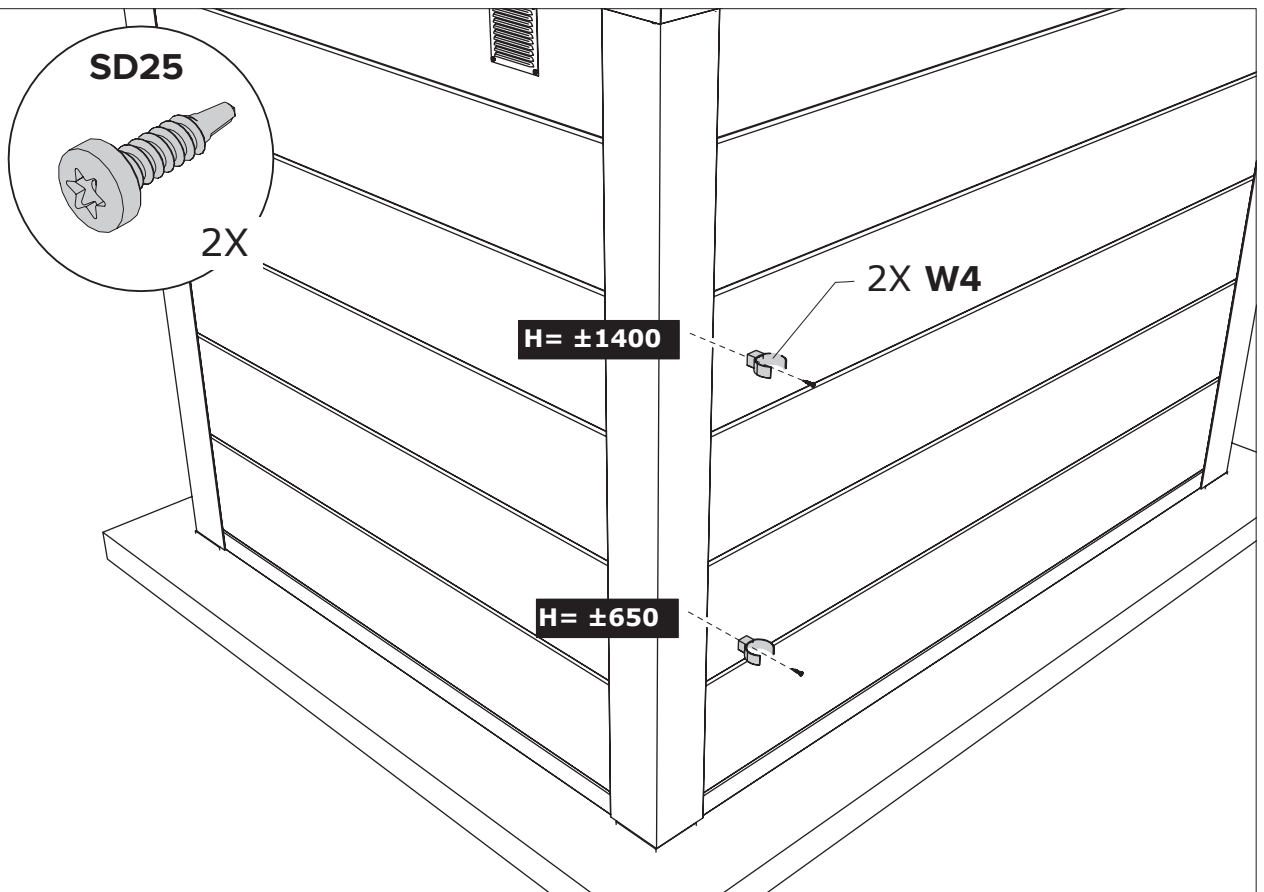

Drain / Afwatering / Drainage / Drainage

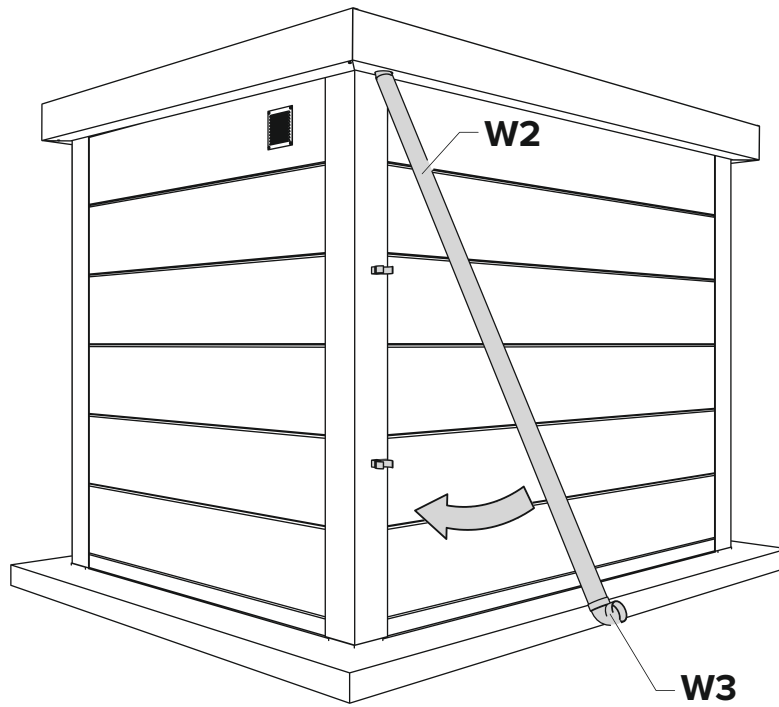

Drain / Afwatering / Drainage / Drainage

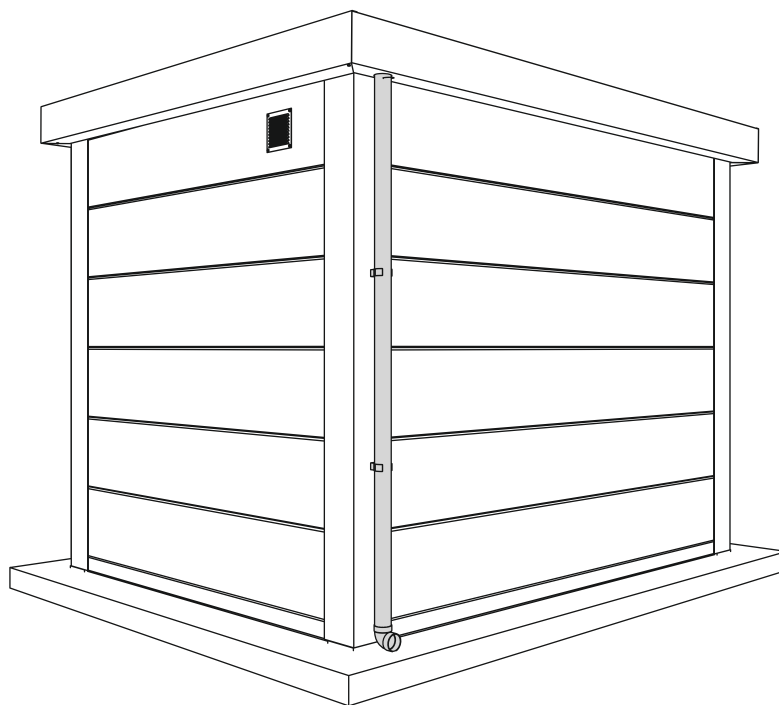

Drain / Afwatering / Drainage / Drainage

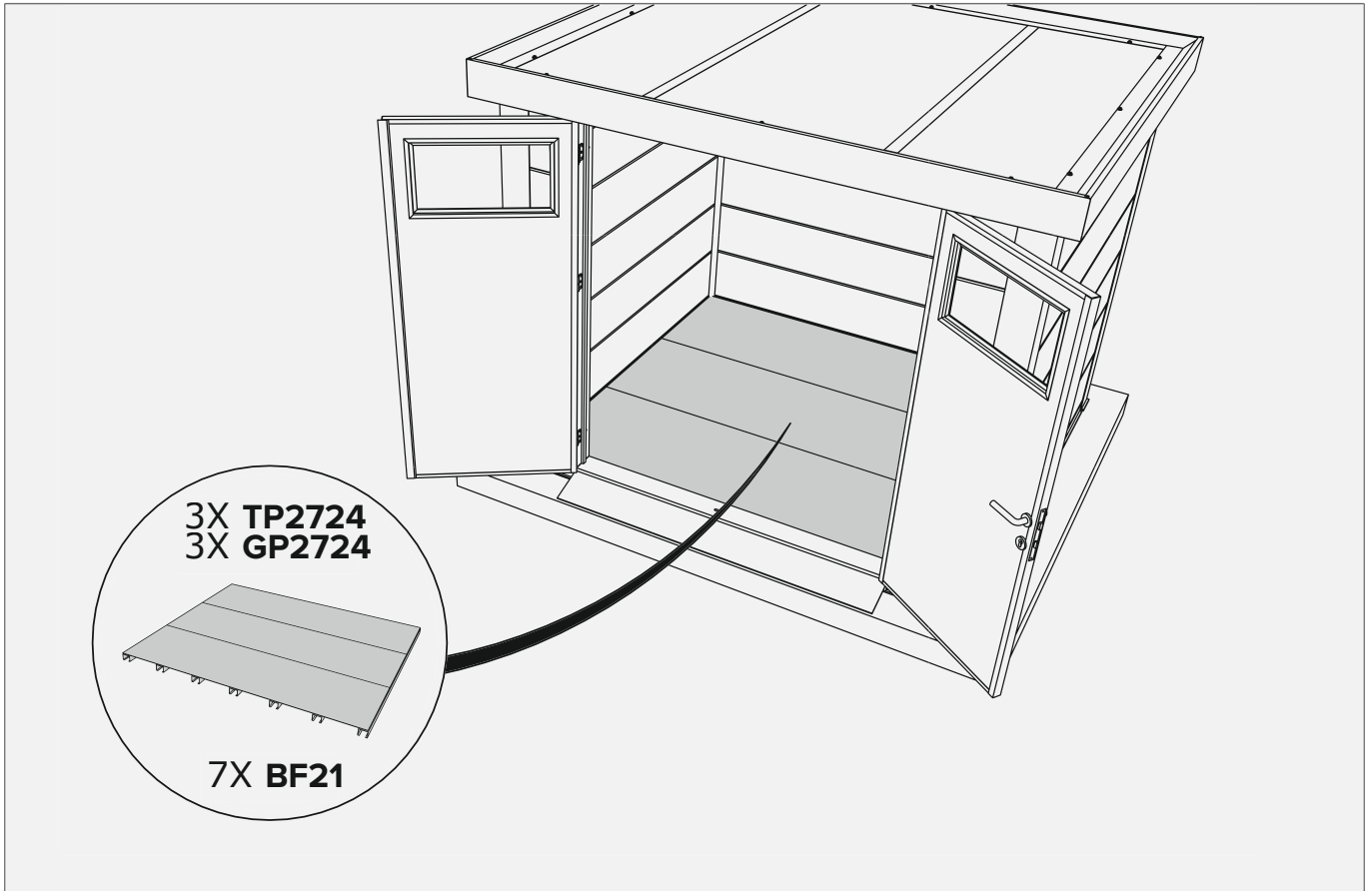

Sol / Vloer / Floor / Boden

Option / Optie / Option / Option

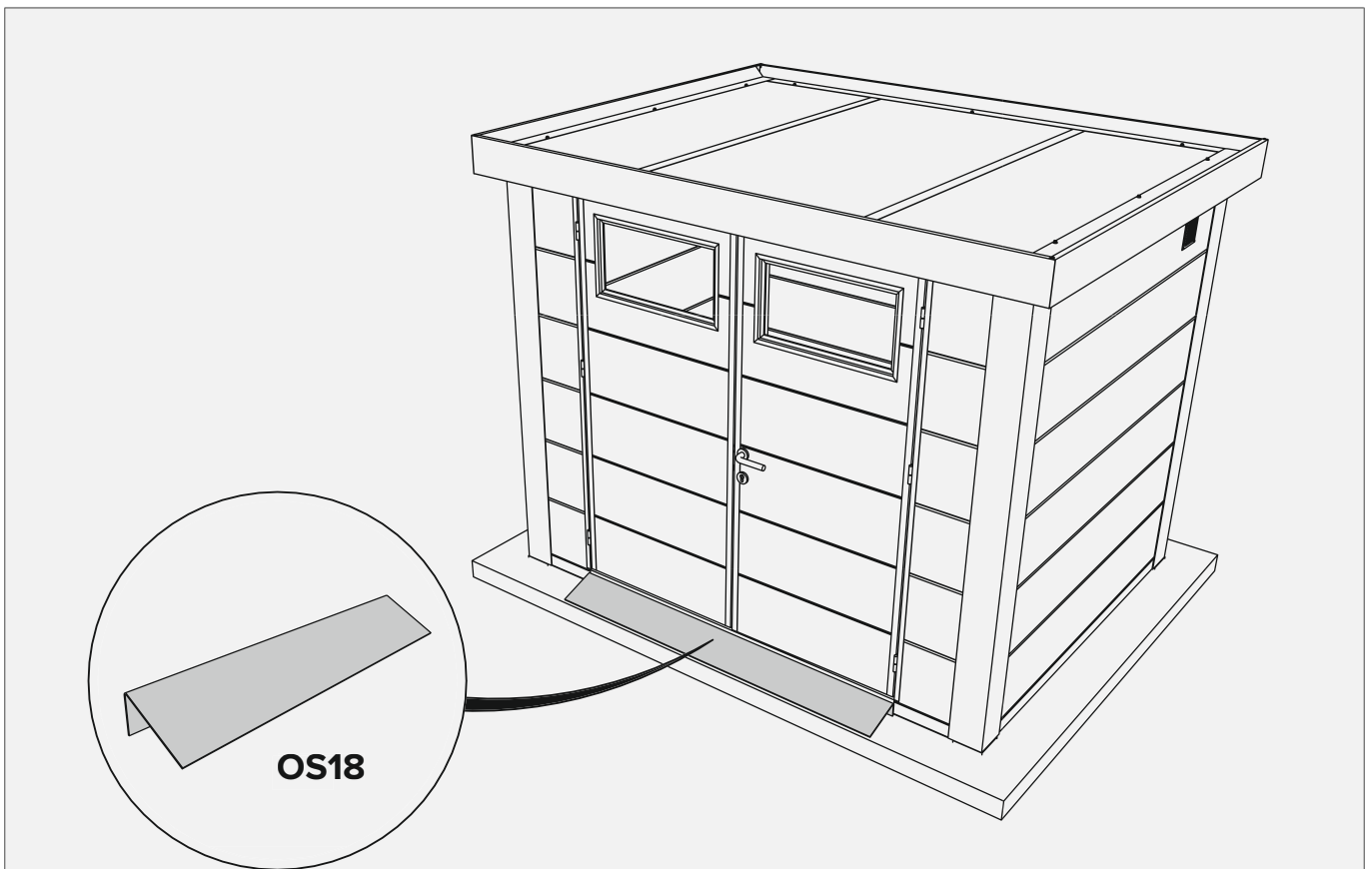

Rampe / Oprijplaat / Ramp / Rampe

Option / Optie / Option / Option

WICHTIG

Sie haben eine Beanstandung?



Allgemeine Daten

Bitte ergänzen Sie die folgenden Fragen! **(Bitte immer mit Fotonachweis)**

Projektnummer
(siehe Deckblatt)

Haustyp-Modell
(Eleganto)

Datum der Anlieferung

Datum der Beanstandung

Name des Händlers

Ist das Haus von Finnhaus-Monteuren aufgebaut worden?

JA

NEIN

Wenn nicht, durch wen wurde das Haus aufgebaut?

Name

Straße / Nr.

Telefonnummer / Handy

PLZ / Ort

Grund zur Beanstandung

*Hier haben Sie Platz,
Ihr Problem zu beschreiben.*

Bitte bei Beschädigung eindeutige Fotos erstellen. Fehlteile vermerken
Sie bitte in der originalen Teile- / Stückliste mit Mengenangabe (n):
**Ohne diesen Vordruck kann eine Beanstandung nicht bearbeitet
und / oder anerkannt werden.**

Kundendienst

E-Mail Eleganto-service@telluria.eu

Hotline 0032 800-11564

Montag - Freitag: 09:00 - 16:00 Uhr



Serviceleitfaden

Sie, oder Ihr Kunde haben eine Beanstandung

Eine Beanstandung ist nicht gewollt, kann aber passieren und sollte so schnell wie möglich bearbeitet werden. Um eine schnelle Bearbeitung zu gewährleisten bitten wir um Ihre Mithilfe.

Bei der Anlieferung erkennbare Beschädigungen bitte immer den Fotonachweis erstellen und auf dem Frachtbrief / Lieferschein dokumentieren.

Kommt beim Öffnen des Paketes beschädigte Ware zum Vorschein, bitte immer Fotonachweise erstellen und auf der Teileliste kenntlich machen, damit wir Ihnen das richtige Ersatzteil zusenden können.

Bitte anhand der Teileliste/Stückliste gegebenenfalls Fehlteile vermerken und per Mail zusenden.

Eine Beanstandung bitte immer schriftlich per Mail / Hotline mit folgenden Angaben von Ihrem Kunden anmelden:

- ✓ Haustyp (Eleganto ...)
- ✓ Projektnummer (an der Verpackung/Deckblatt Anleitung)
- ✓ Bildmaterial und Teileliste/Stückliste mit der Kennzeichnung von Fehlteilen oder beschädigten Teilen
- ✓ Auftragsnummer oder Lieferschein oder Rechnungsnummer der Firma Wolff Finnhaus

Wir stehen Ihnen für alle Fragen gerne zu Verfügung, und bedanken uns für Ihre Mithilfe.

Kundendienst - Mail: eleganto-service@telluria.eu



Merci de respecter l'environnement !

Pour une élimination correcte des déchets, il faut trier les différents matériaux conformément à la législation en vigueur.

Droits d'auteur Telluria. Tous droits réservés. Aucun élément de la présente publication ne peut être reproduit ou diffusé sans l'autorisation écrite de Telluria. Les informations figurant dans la présente publication sont, pour des raisons techniques et/ou commerciales, sujettes à modification sans avis préalable.

Telluria ne peut être tenue pour responsable des éventuels oublis et erreurs de la présente publication.

Draag zorg voor het milieu!

Voor een correcte afvalverwijdering moeten de verschillende materialen volgens de toepasselijke regelgeving worden gescheiden.

Auteursrechten Telluria. Alle rechten voorbehouden. Niets in deze publicatie mag worden gereproduceerd of verdeeld zonder de schriftelijke toestemming van Telluria.

De gegevens in deze publicatie zijn, omwille van technische en/of commerciële redenen, onderhevig aan wijziging zonder voorafgaande kennisgeving.

Telluria is niet verantwoordelijk voor eventuele vergissingen of onjuistheden in deze publicatie.

Protect the environment!

To ensure waste is disposed of correctly, the different materials must be separated according to the applicable regulations.

Copyright Telluria. All rights reserved. Nothing in this publication may be reproduced or distributed without written permission from Telluria. The information in this publication is subject to change for technical and/or commercial reasons at any time and without notice.

Telluria is not responsible for any errors or inaccuracies in this publication.

Achten Sie auf die Umwelt!

Um eine ordnungsgemäße Entsorgung zu gewährleisten, müssen die verschiedenen Materialien entsprechend den geltenden Vorschriften getrennt werden.

Copyright Telluria. Alle Rechte vorbehalten. Kein Teil dieser Publikation darf ohne schriftliche Genehmigung von Telluria vervielfältigt oder verbreitet werden. Aus technischen und/oder kommerziellen Gründen können sich die in dieser Publikation enthaltenen Informationen ohne vorherige Ankündigung ändern.

Telluria ist nicht verantwortlich für Fehler oder Ungenauigkeiten in dieser Publikation.

SIE HABEN FRAGEN ZU DIESEM PRODUKT:

Bitte beachten Sie dazu die Informationen aus dem Serviceleitfaden.

Kostenlose deutschsprachige Service Hotline: 0032 800 - 11564 / Montag - Freitag: 09:00 - 16:00 Uhr

Kundendienst-Mail: eleganto-service@telluria.eu

