

53455

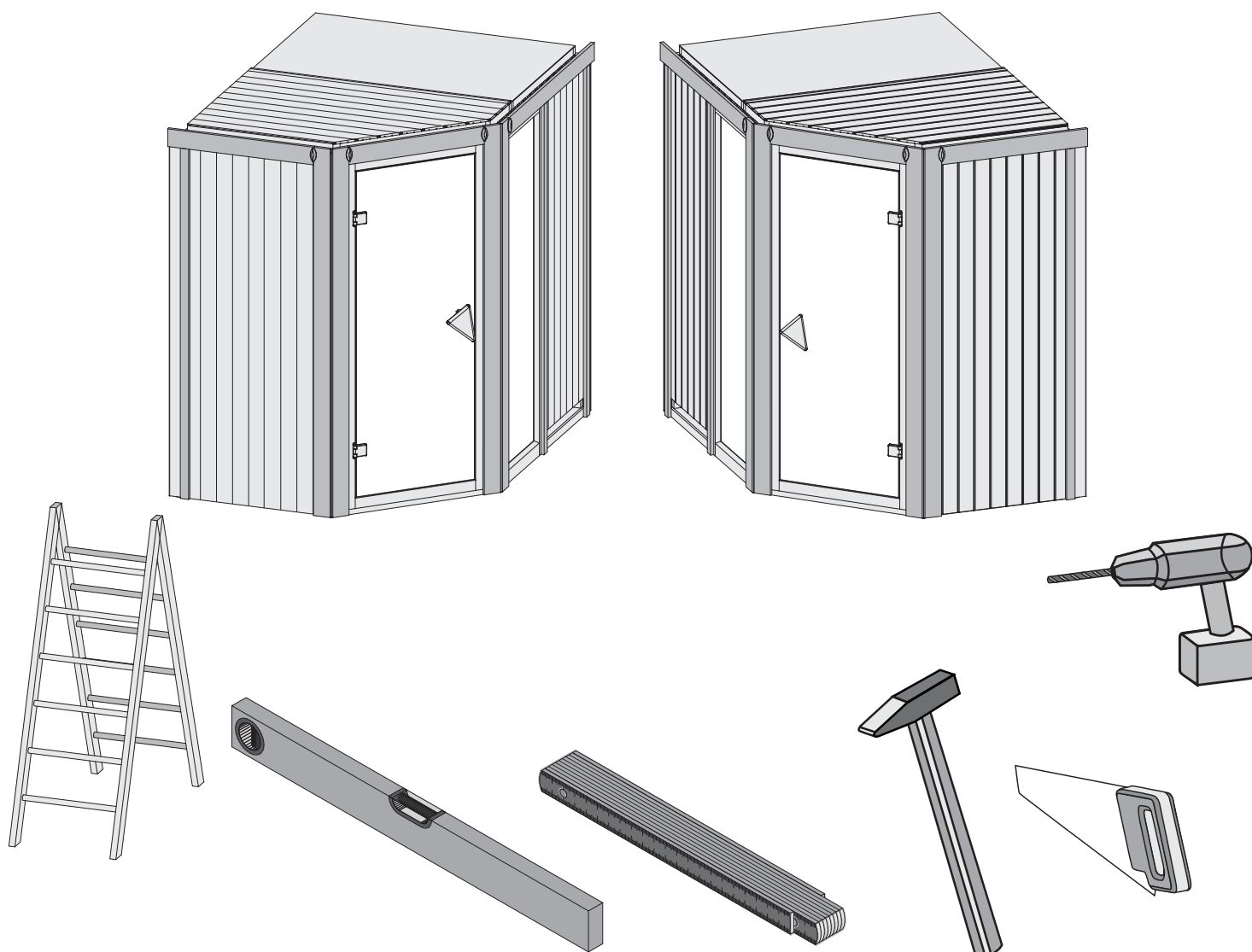

 **Aufbauanleitung**

 **notice de montage**

 **Building Instructions**

 **montagehandleiding**

 **Instrucciones de construcción**

 **Istruzioni per il montaggio**

 **Montážní návod**

 **Service-Hotline: +49 421 38693 33**



Vergleichen Sie zuerst die Materialliste mit Ihrem Paketinhalt! Bitte haben Sie Verständnis, dass Beanstandungen nur im nicht aufgebauten Zustand bearbeitet werden können!



En primer lugar, compare la lista de material con el contenido del paquete. Rogamos entienda que las reclamaciones sólo pueden ser tramitadas antes de montar el objeto!



Nejprve přezkontrolujte obsah balení podle materiálového listu! Mějte pochopení pro to, že případnou reklamaci se můžeme zabývat pouze tehdy, když díly nebudou smontované! Za pomoci tohoto seznamu můžete jednotlivé díly přiřadit k montážnímu návodu.



Vergelijk eerst de lijst van materialen met de inhoud van uw pakket! Reclamaties kunnen alleen in behandeling worden genomen zolang de onderdelen nog niet zijn gemonteerd!



First compare the list of materials with your package contents! Please understand that complaints can be processed in the non-built status only!



Commencez par comparer la liste du matériel avec le contenu de votre paquet! Sachez que nous traitons uniquement les réclamations concernant le matériel à l'état non monté!



Confrontate questa distinta materiali prima con il contenuto del pacchetto! Vi preghiamo di comprendere che eventuali reclami possono essere accolti solo prima del montaggio!

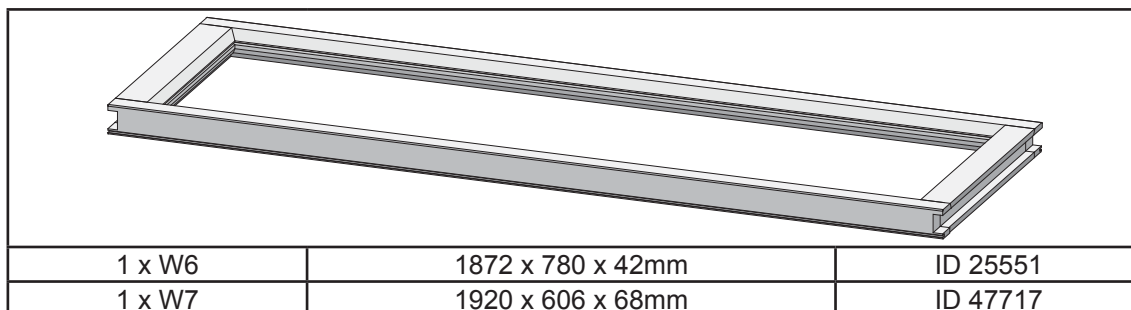
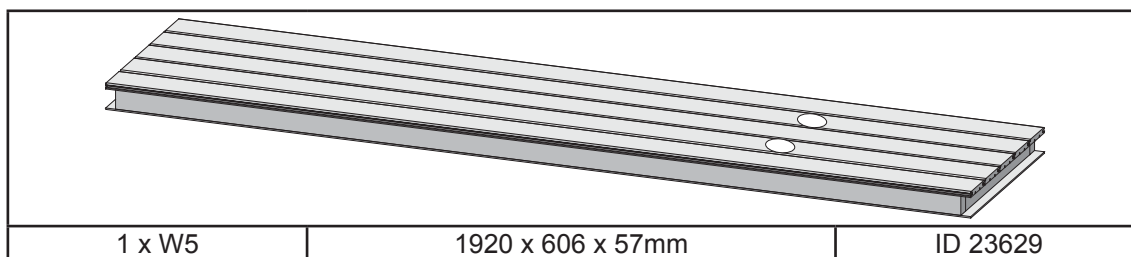
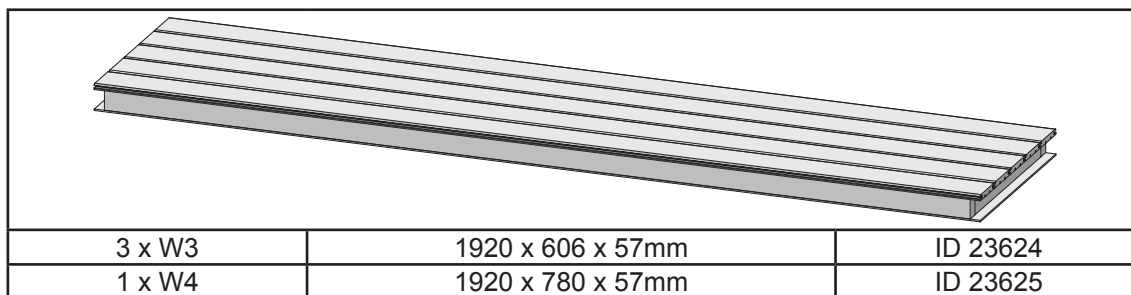
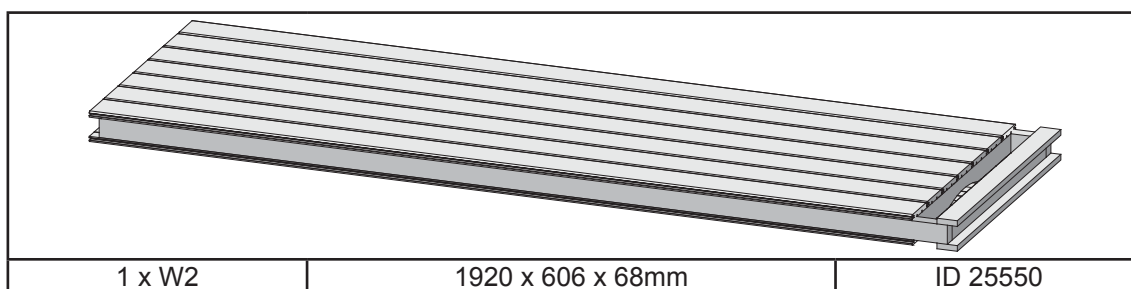
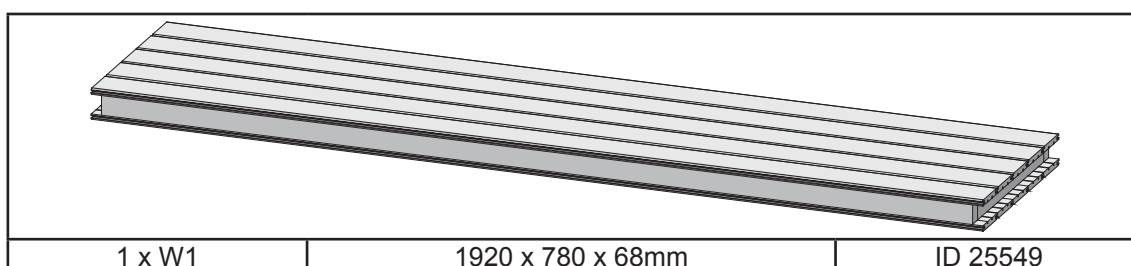
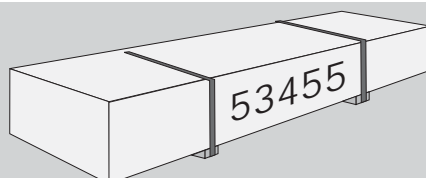

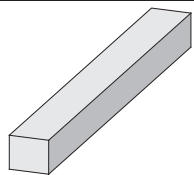

5 x B1	1920 x 19 x 3mm	ID 20799
4 x B2	70 x 45 x 18mm	ID 26366
6 x B3	800 x 45 x 18mm	ID 24796
3 x B4	1884 x 45 x 18mm	ID 48037
4 x B5	480 x 95 x 18mm	ID 20930
4 x B6	580 x 95 x 18mm	ID 16708
1 x B7	765 x 95 x 18mm	ID 26357
1 x B8	790 x 95 x 18mm	ID 24180
1 x B9	1260 x 95 x 18mm	ID 53455
1 x B10	300 x 120 x 18mm	ID 22467
2 x B11	550 x 42 x 28mm	ID 24053
2 x B12	774 x 42 x 28mm	ID 24112
1 x B13	1382 x 42 x 28mm	ID 24107
2 x B14	1492 x 42 x 28mm	ID 26397
1 x B15	1759 x 42 x 28mm	ID 24133
2 x B16	1841 x 42 x 28mm	ID 26376
3 x B17	1874 x 52 x 52mm	ID 26165

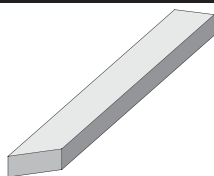

1 x C1	799 x 42 x 28mm	ID 47460
2 x C2	858 x 42 x 28mm	ID 43467
1 x C3	1204 x 42 x 28mm	ID 47461
2 x C4	1247 x 42 x 28mm	ID 25740

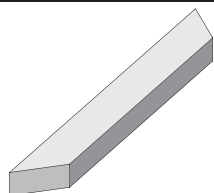

1 x D1	859 x 42 x 28mm	ID 24114
2 x D2	896 x 42 x 28mm	ID 24110

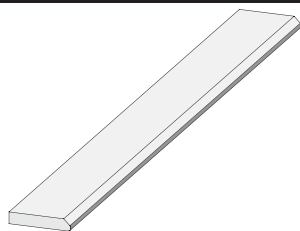

2 x G1	1884 x 58 x 17mm	ID 48521
1 x G2	1980 x 58 x 17mm	ID 52813
3 x G3	1980 x 95 x 17mm	ID 48540

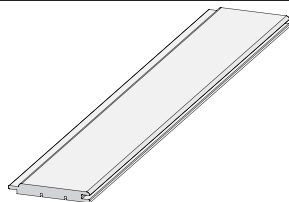

2 x E1	1920 x 97 x 12mm	ID 22863
--------	------------------	----------

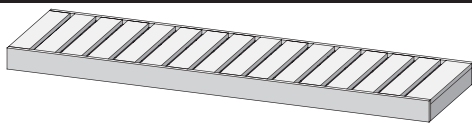

1 x L1	1810 x 250 x 90mm	ID 44617
1 x L2	1810 x 550 x 90mm	ID 21767

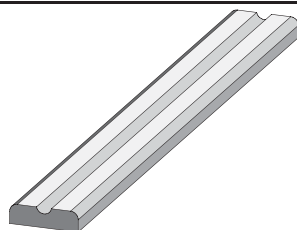

2 x L3	1810 x 90 x 22mm	ID 26112
--------	------------------	----------

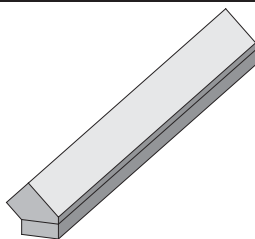

2 x K1	1874 x 76 x 38mm	ID 43464
--------	------------------	----------

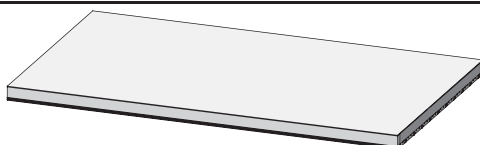

1 x M1	1406 x 918 x 57mm	ID 46970
--------	-------------------	----------

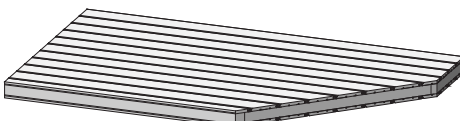

1 x M2	1406 x 918 x 68mm	ID 54566
--------	-------------------	----------

1 x

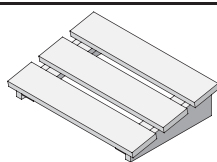

ID 25545

4 x T1

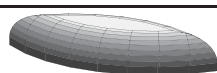

ID 26272



30 x	4 x 30mm	ID 3686
60 x	4 x 50mm	ID 3688
50 x	4 x 70mm	ID 3689
50 x	4,5 x 80mm	ID 9204
15 x	6 x 60mm	ID 14014



120 x	4,5 x 40mm	ID 26285
-------	------------	----------

6 x S1



ID 14266

120 x S3

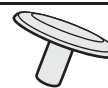

ID 26116

20 x



ID 14005

10m

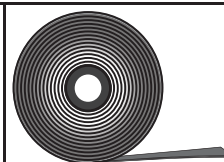

ID 14025

2 x

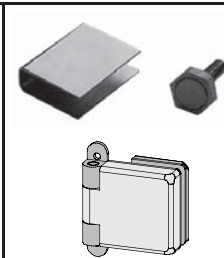

ID 26496

1 x



ID 49649



4 x

3 x 16mm

ID 46376

1 x



ID 50420

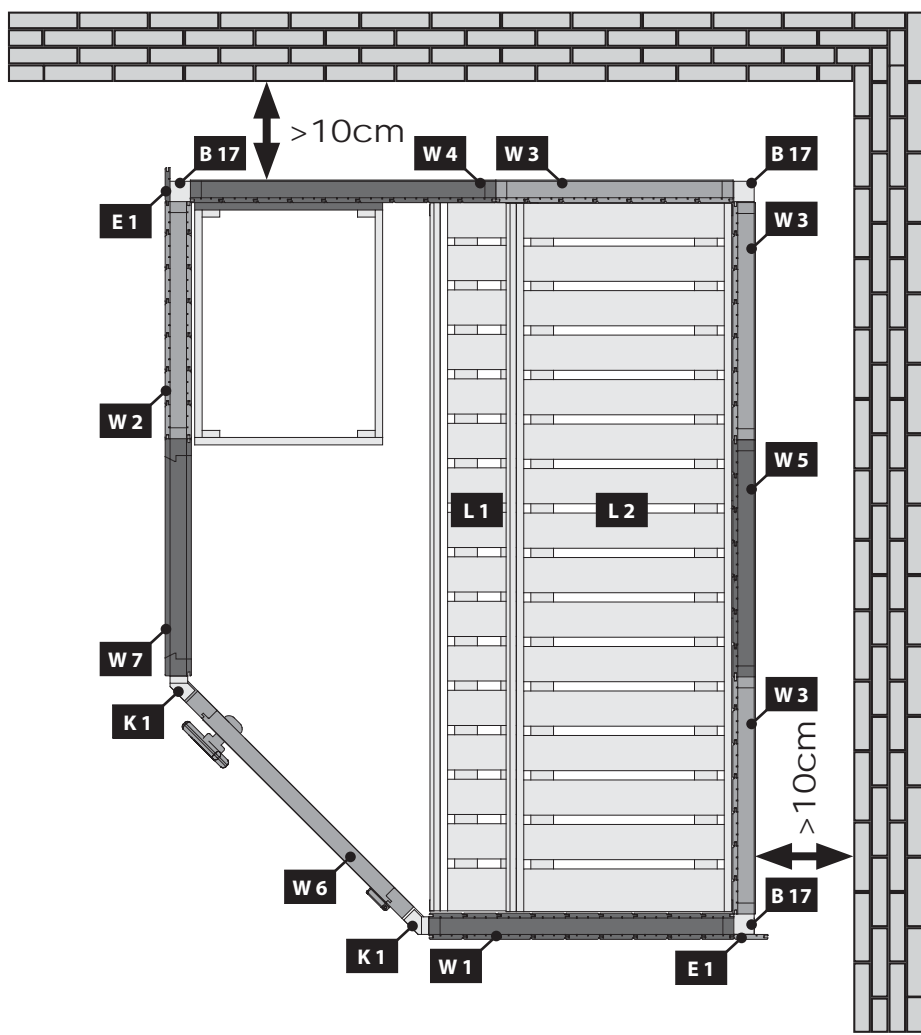
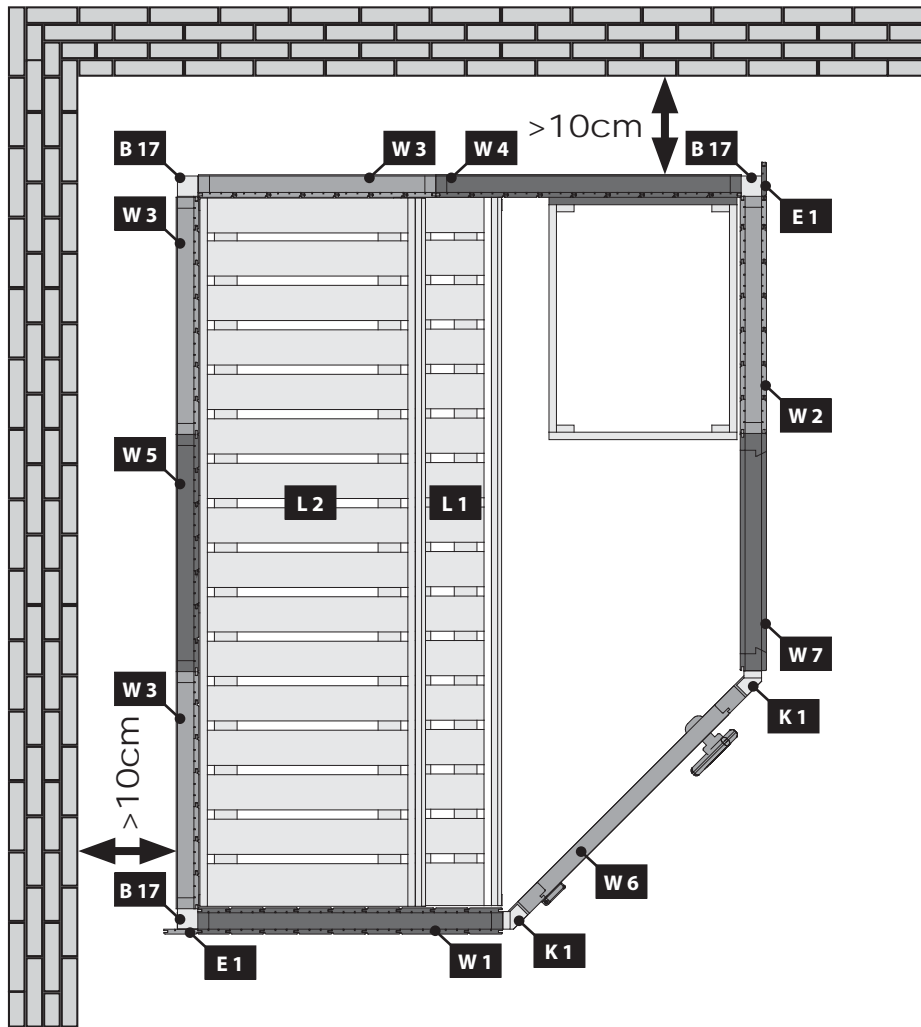

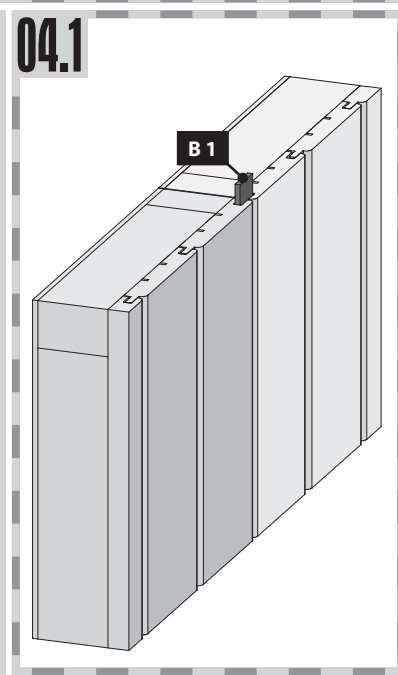
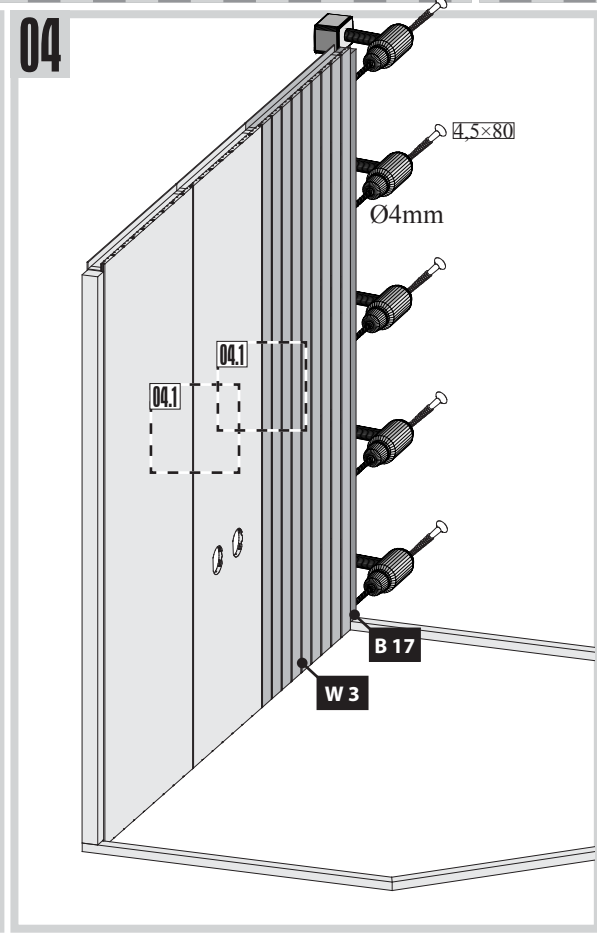
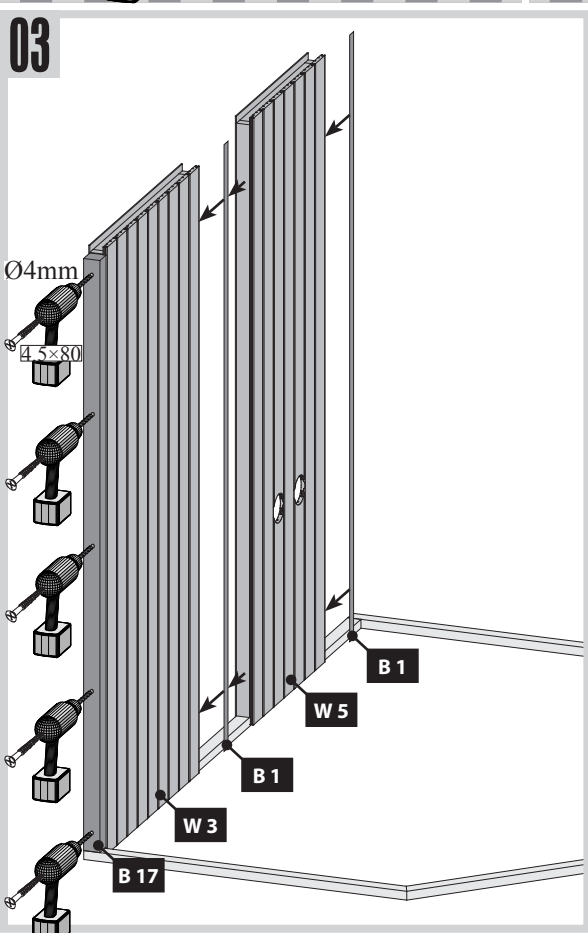
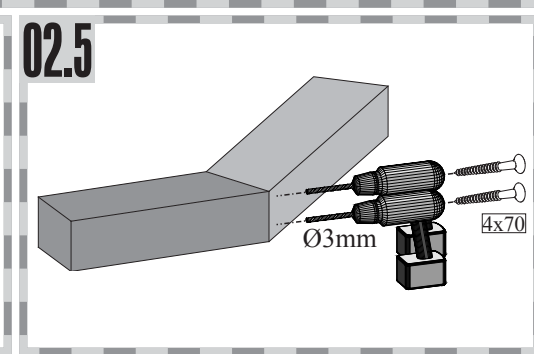
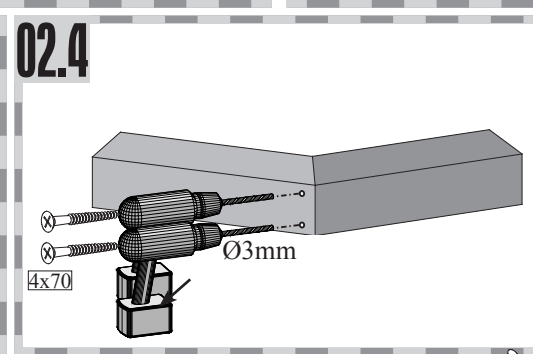
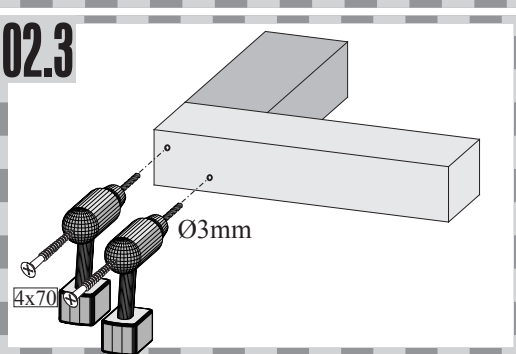
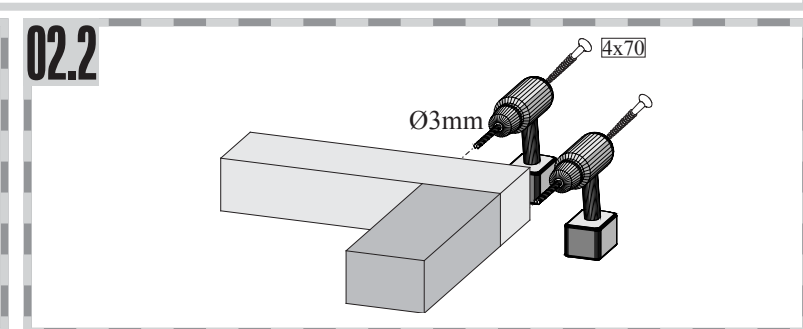
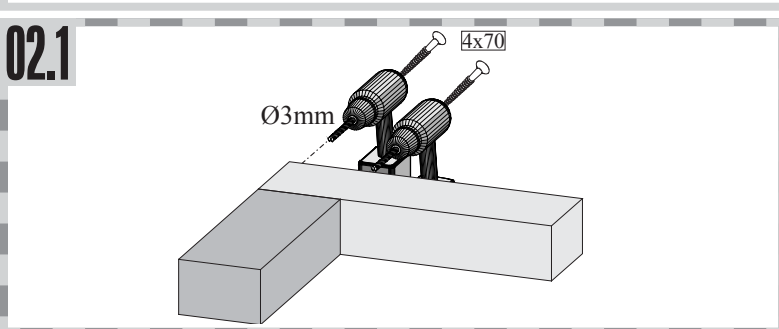
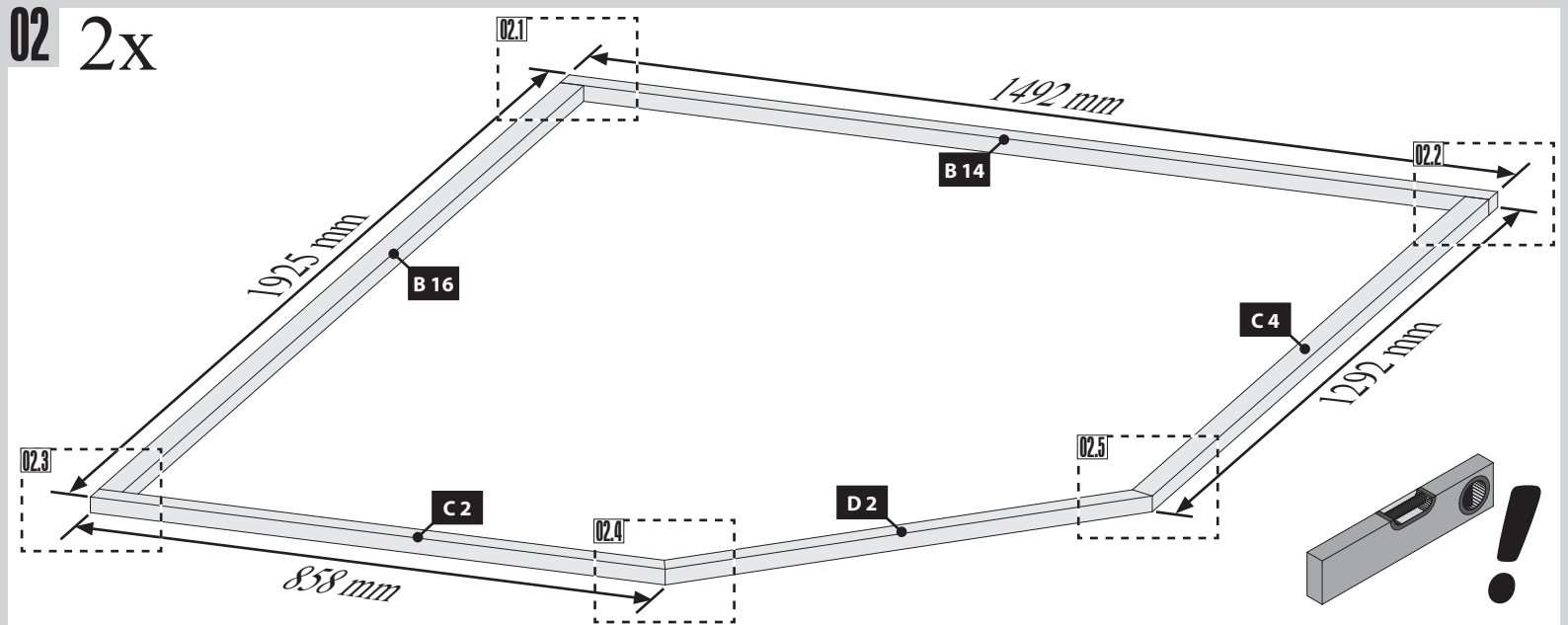

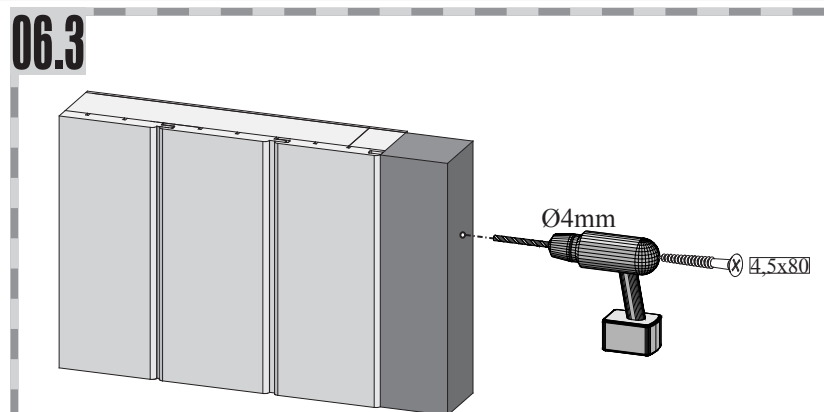
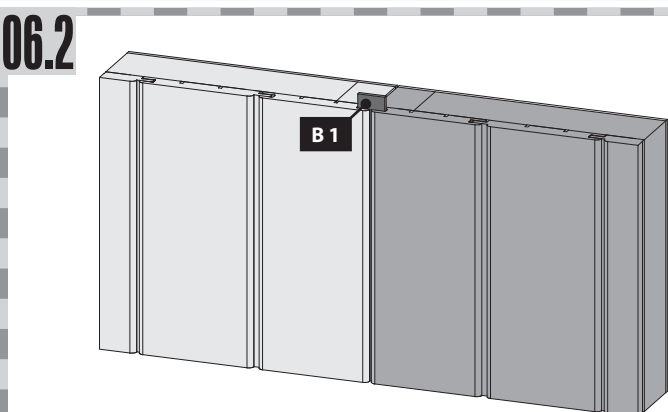
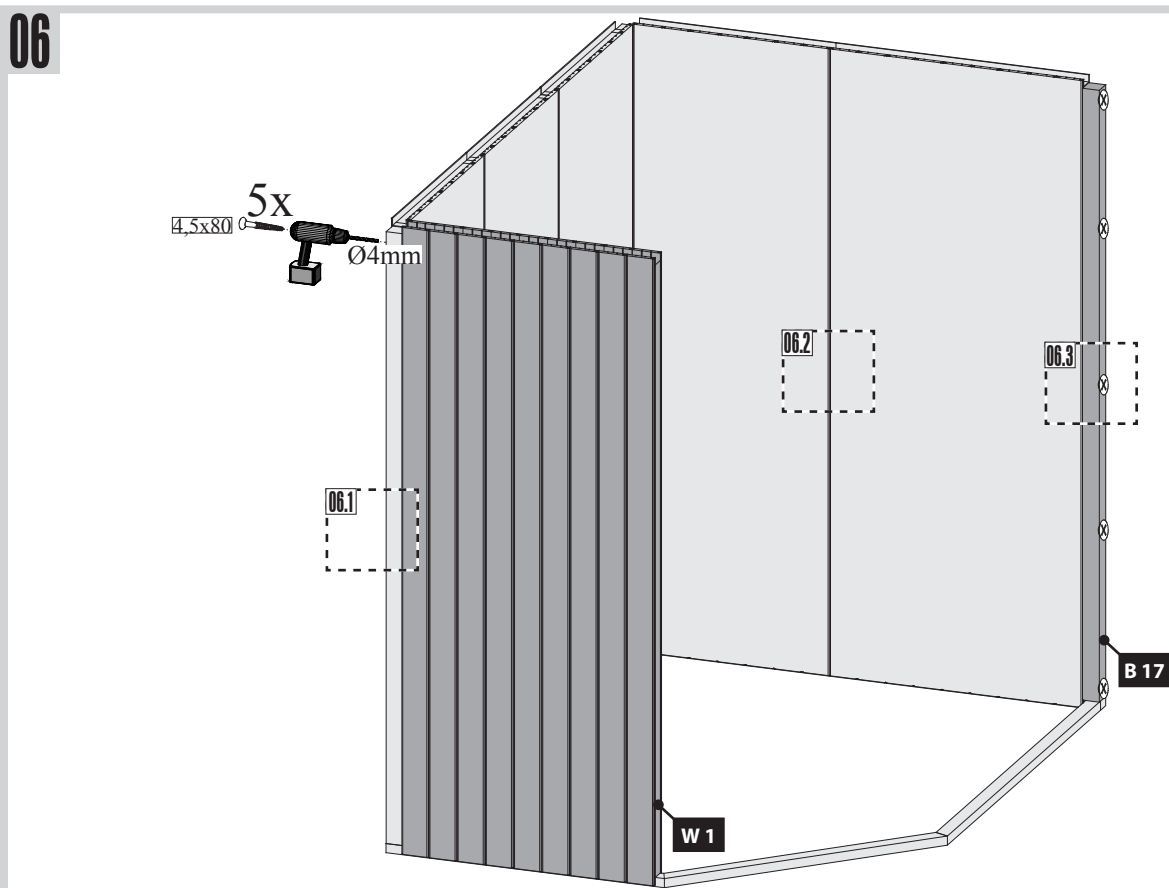
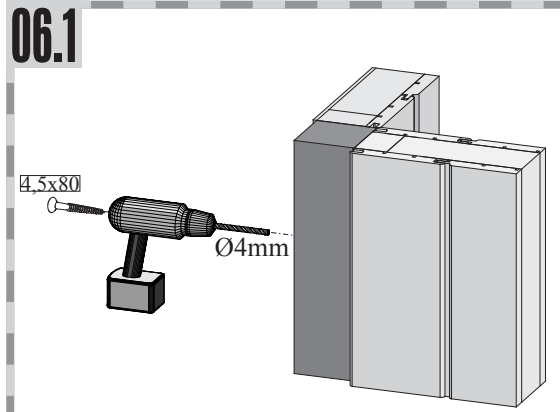
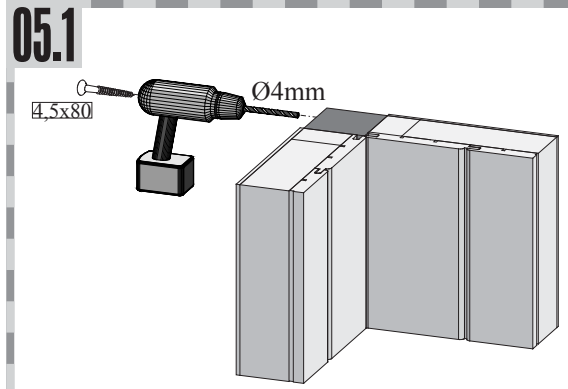
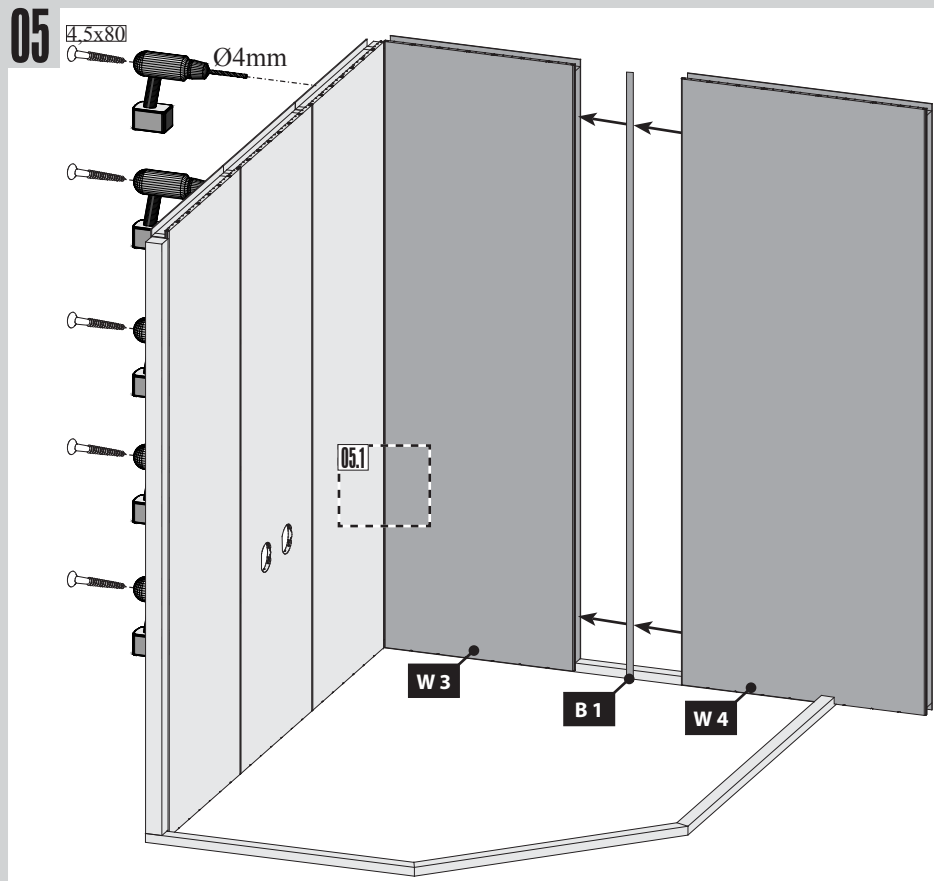

07

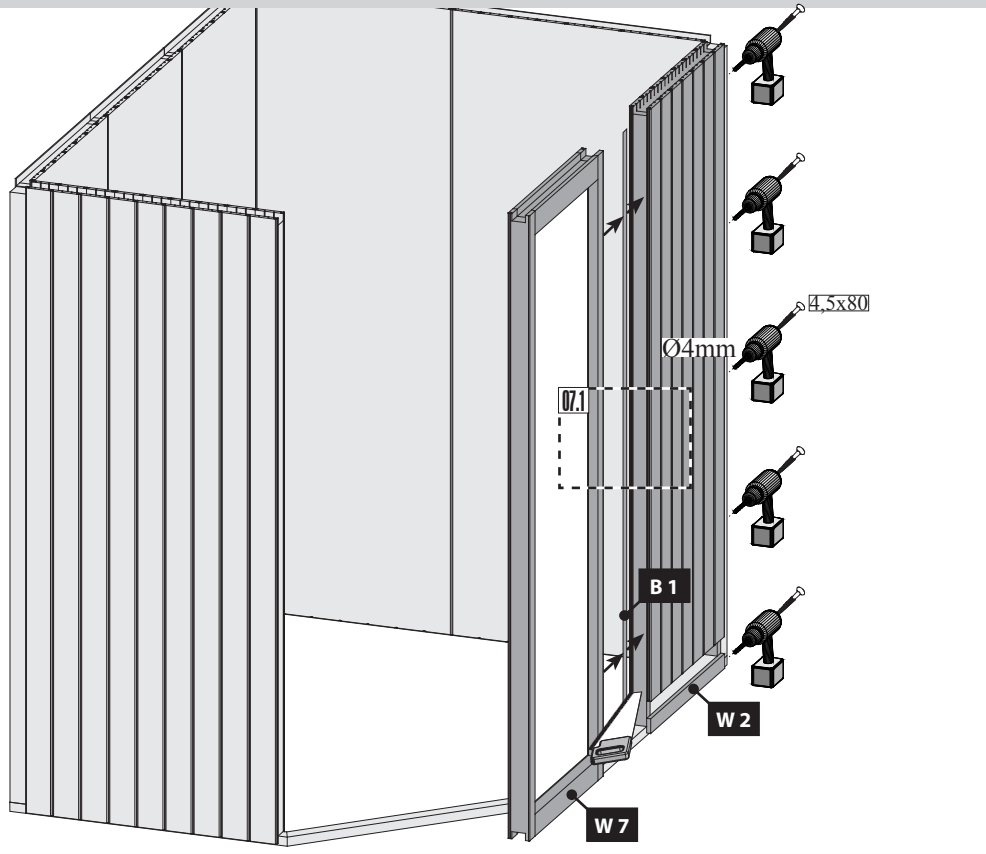

07.1

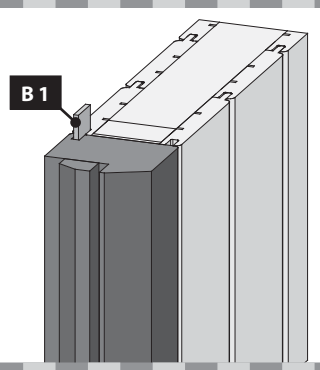

08.1

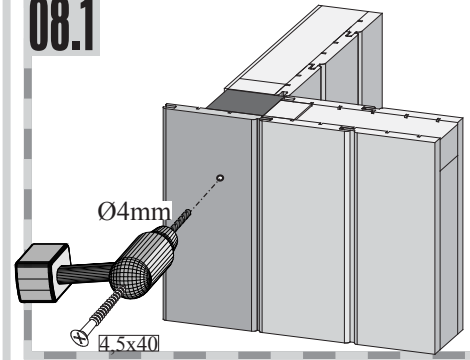

08.2

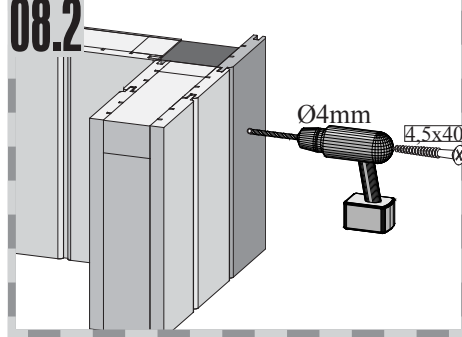

08.3

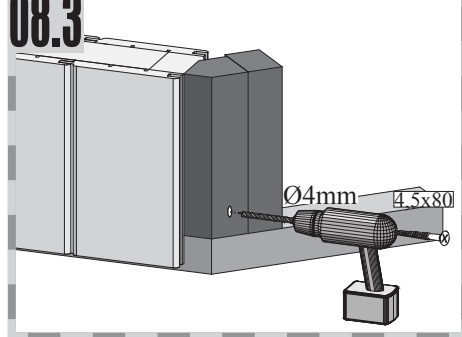

08.4

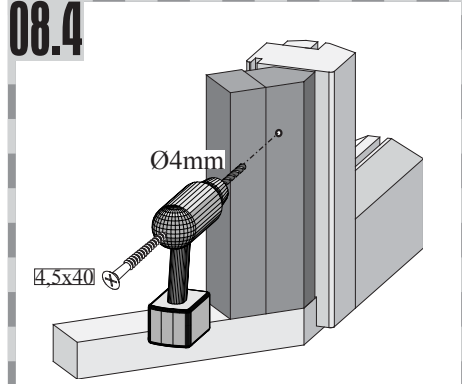

08

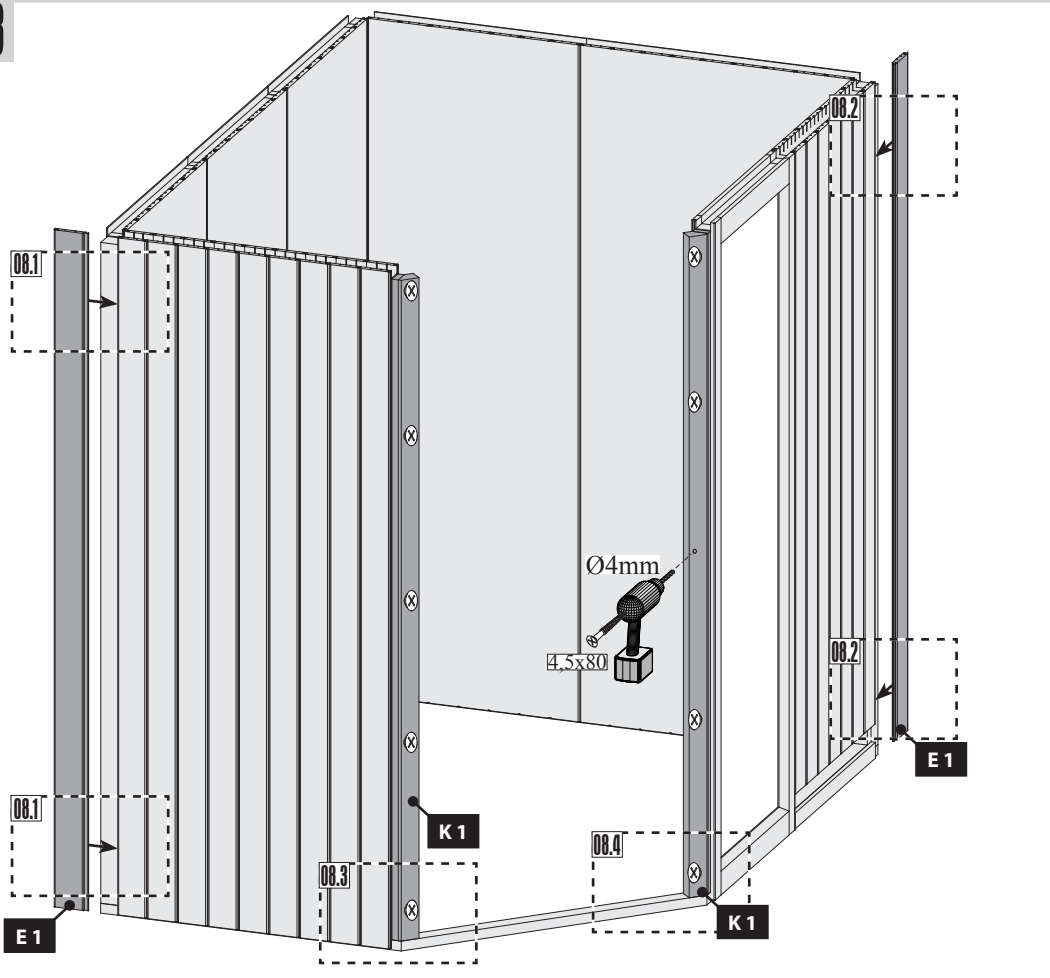

 Einbau Glastür

 Installation of glass door

 Montaje de la puerta de cristal

 Montage porte en verre

 Montage van de glazen deur

 Installazione portello di vetro

!!! 01 — 03 !!!

09

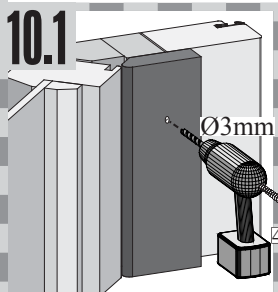
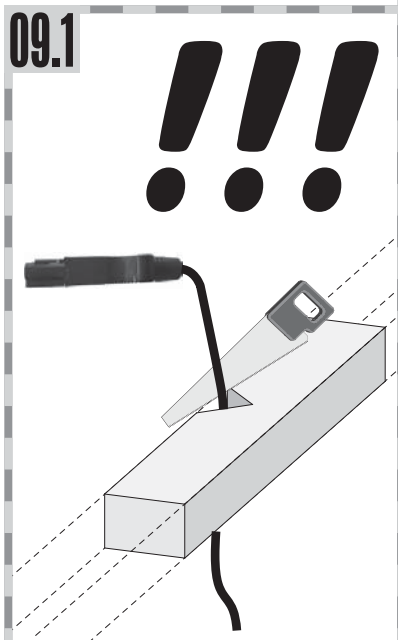
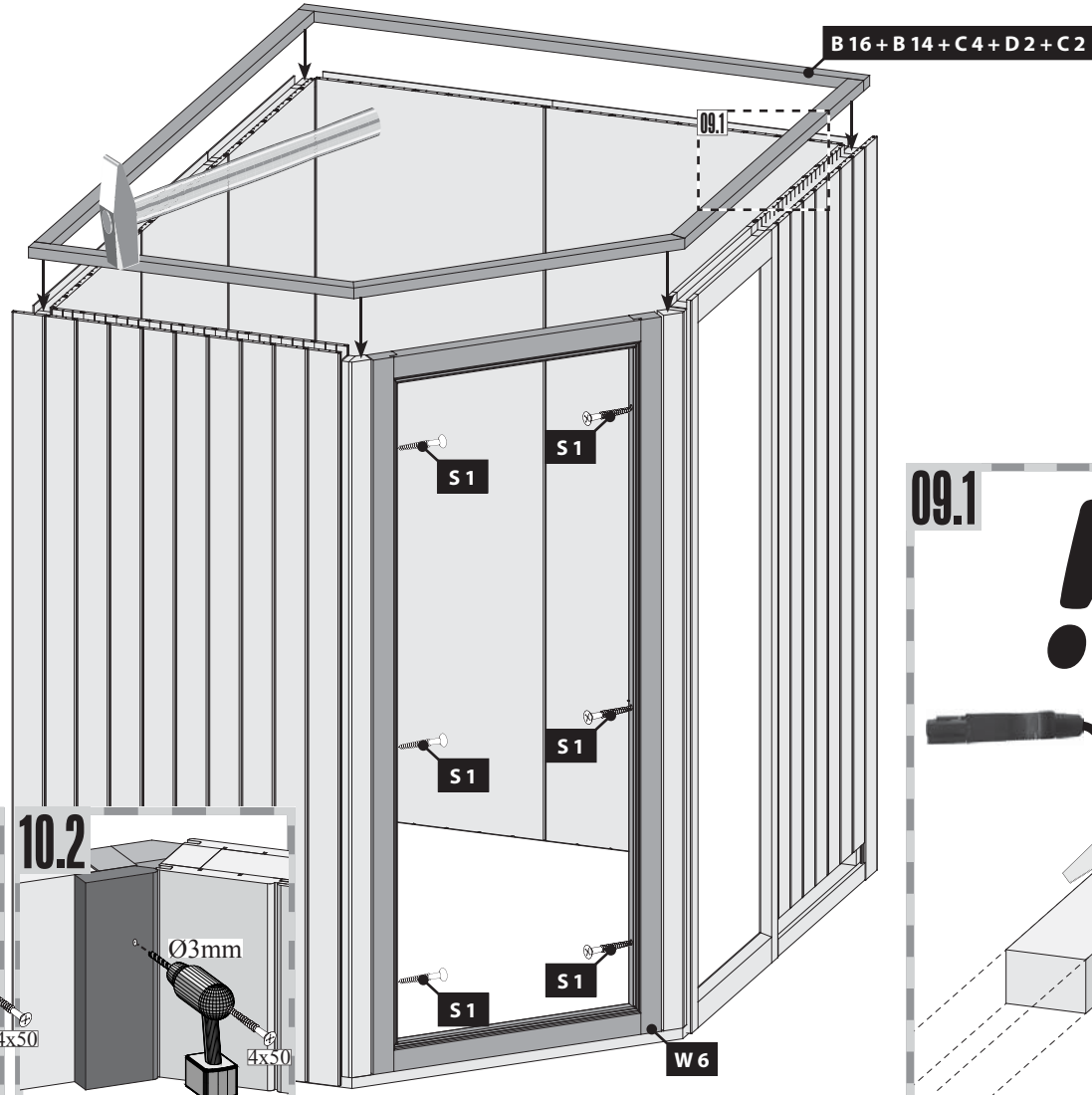

10

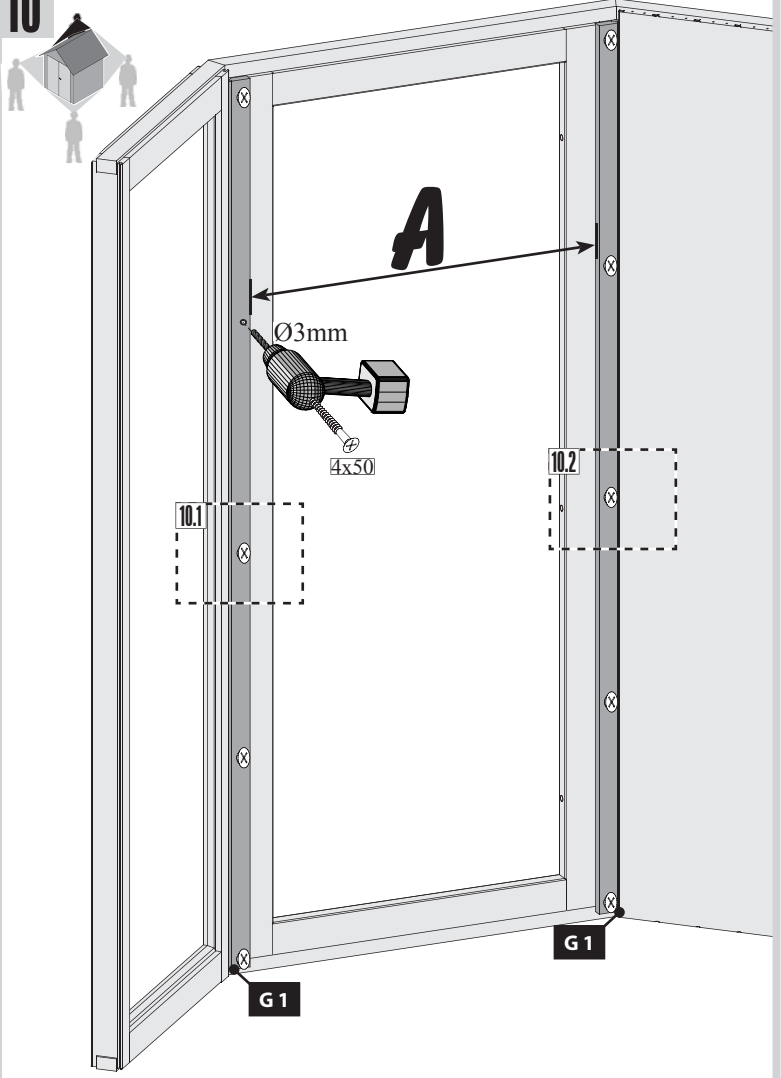

11 2x

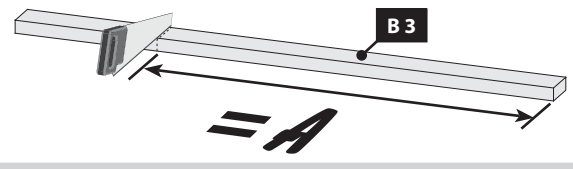

12

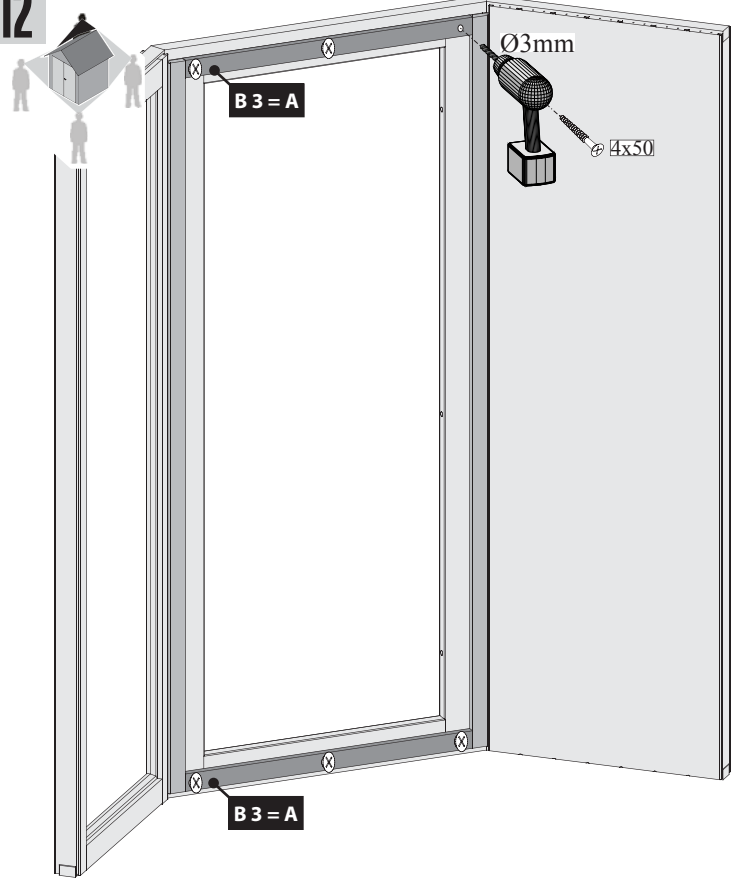

13

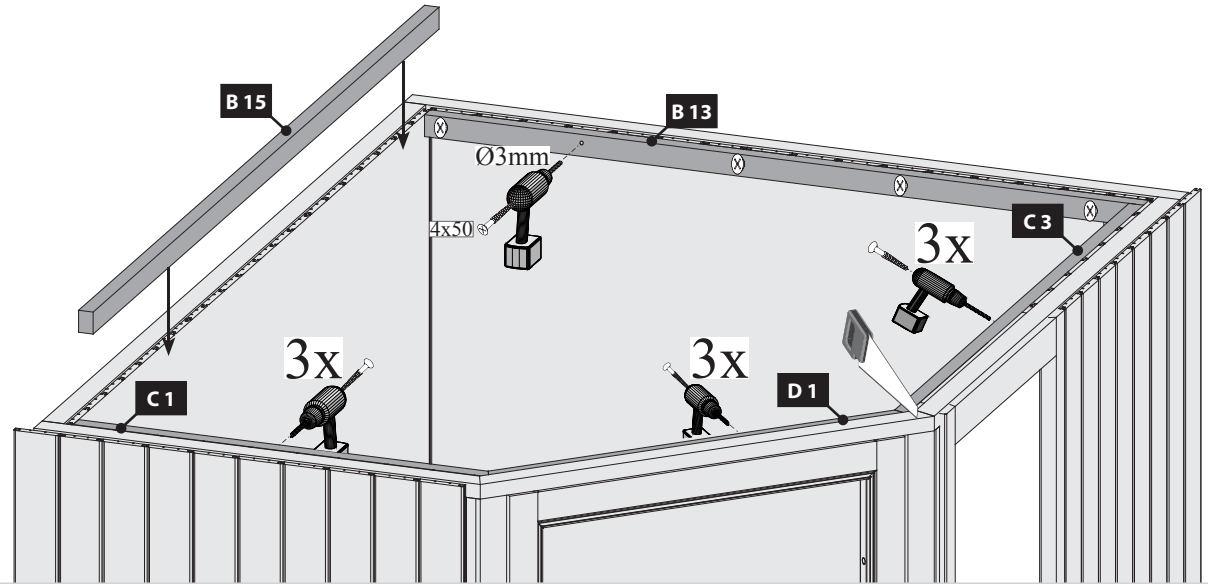
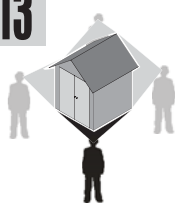

14

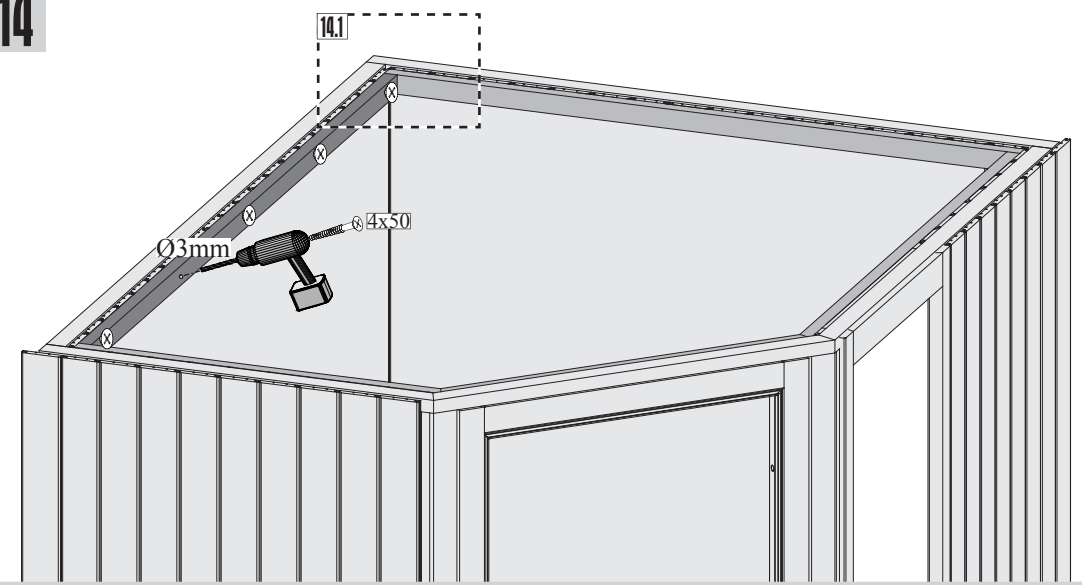

14.1

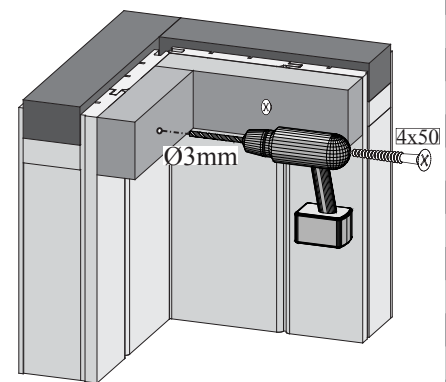

15

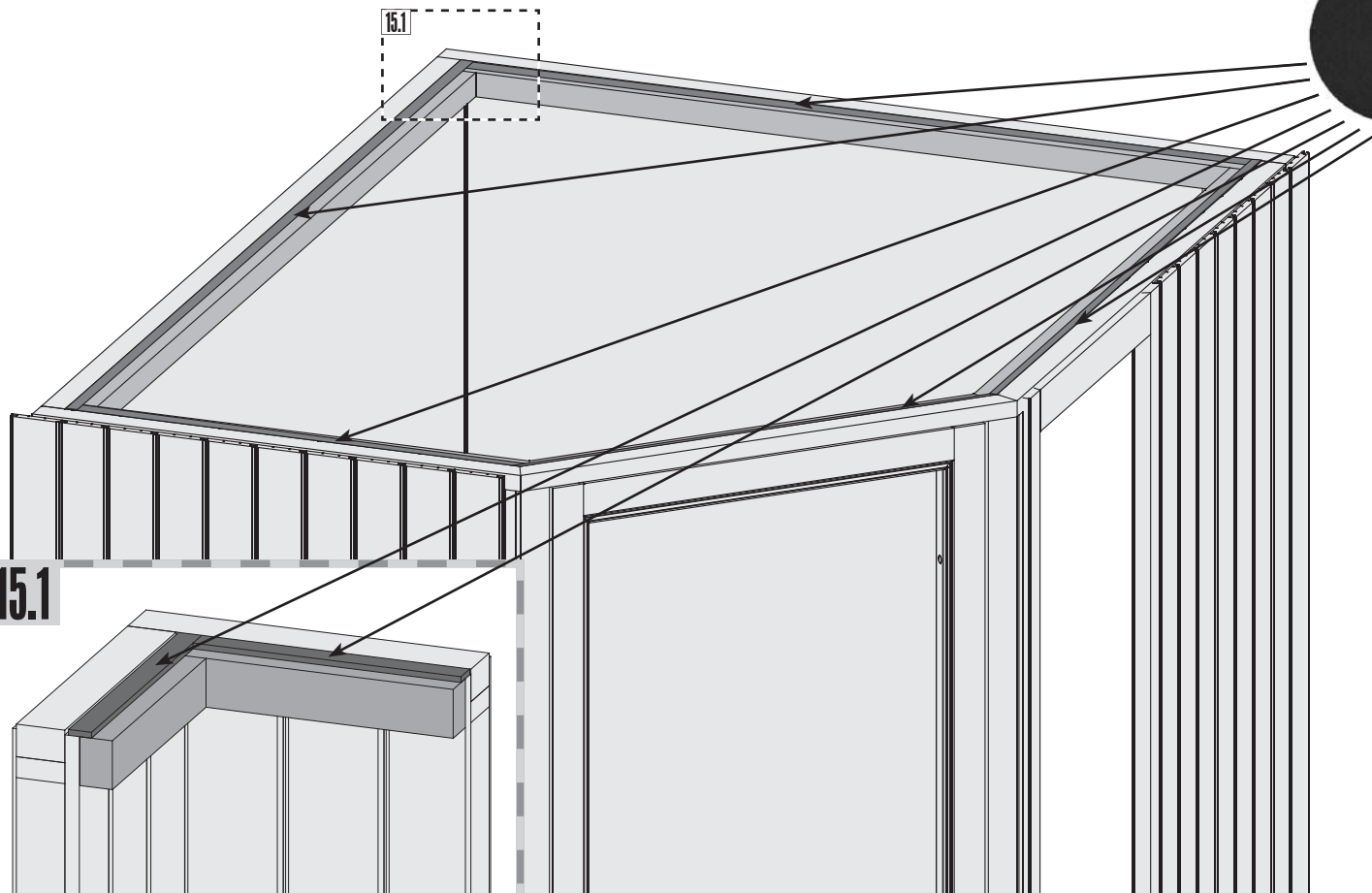

15.1

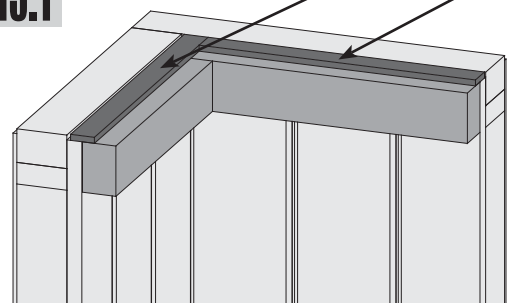

16

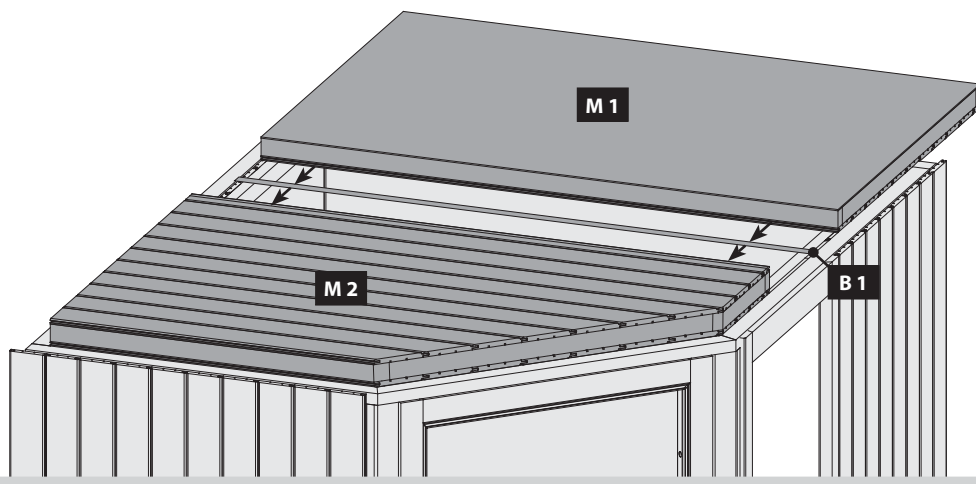

17.1

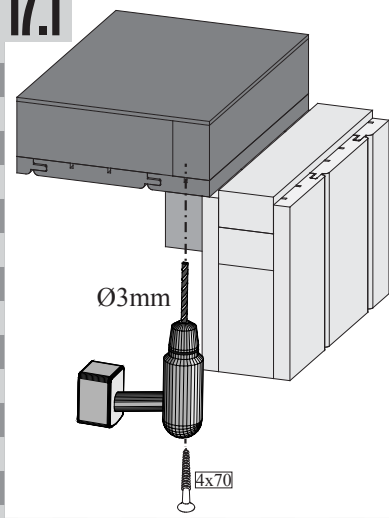

17

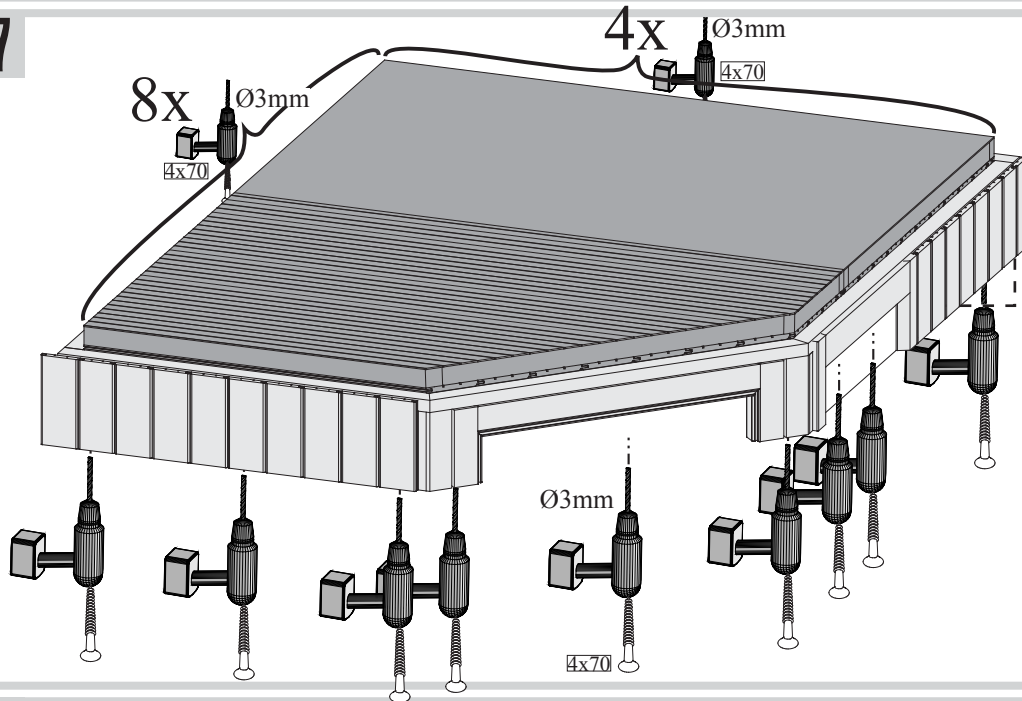

18.1

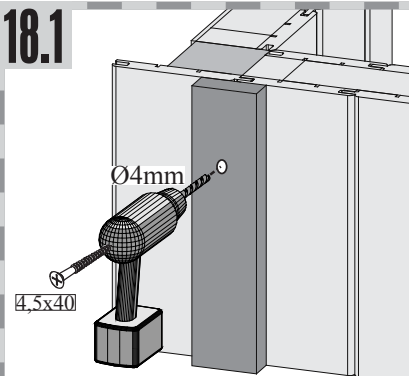

18

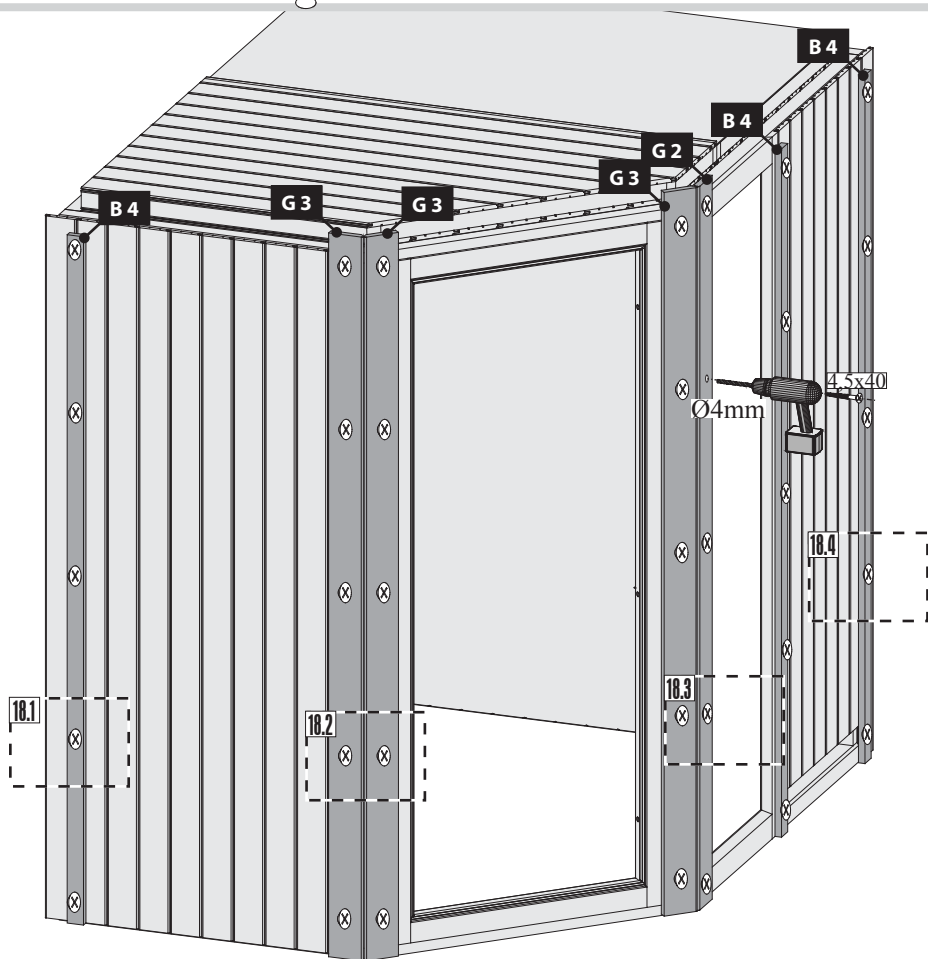

18.2

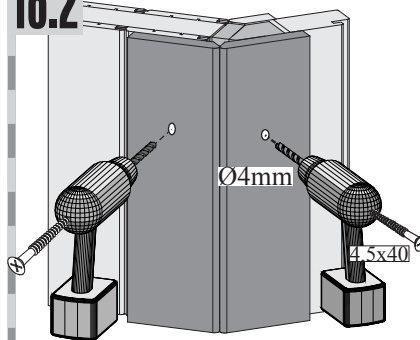

18.3

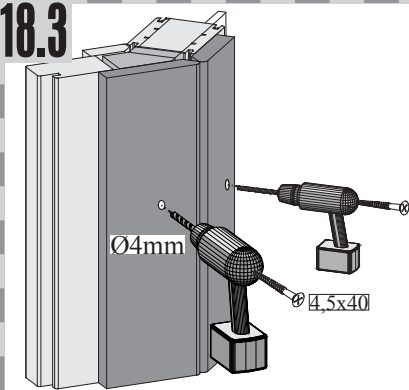

18.4

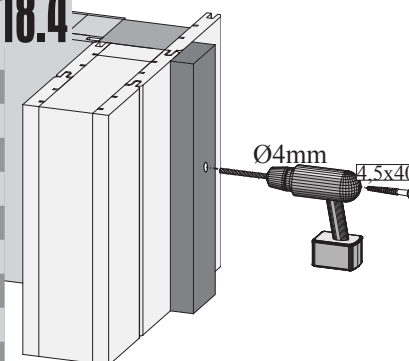

19

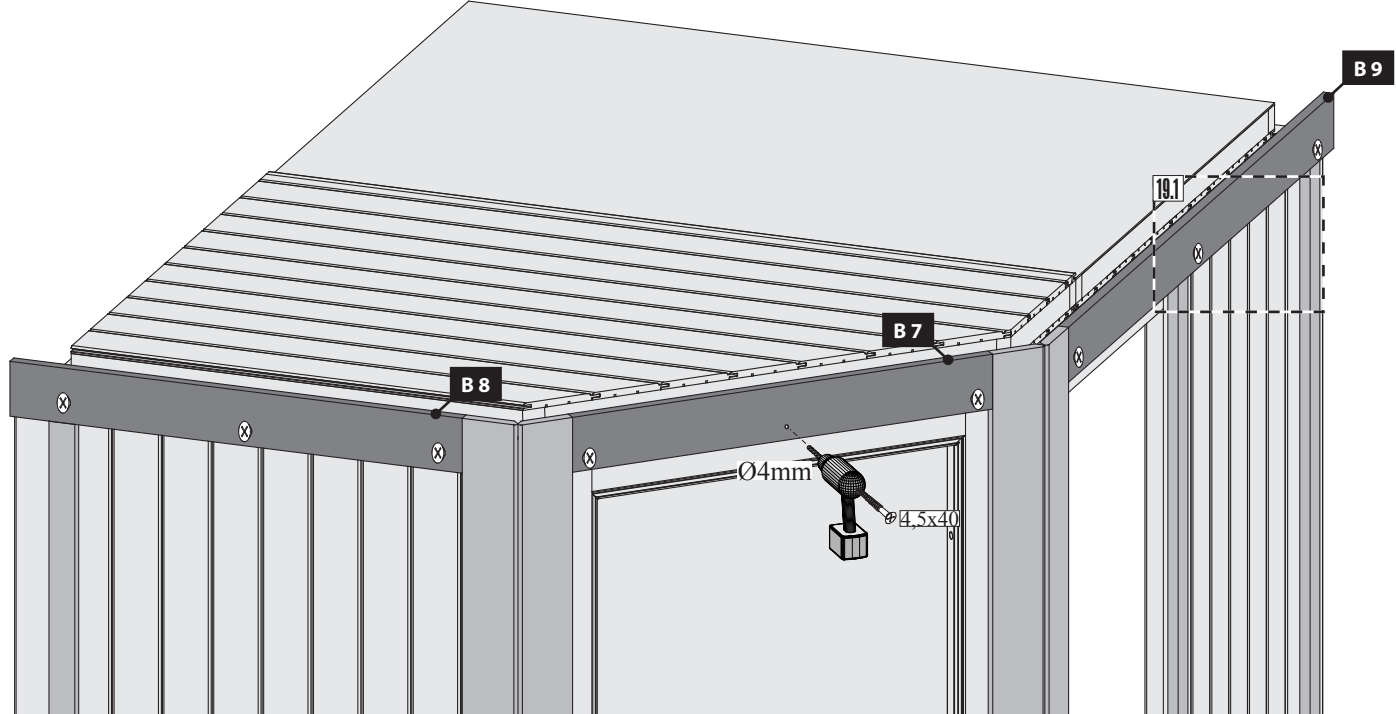

20

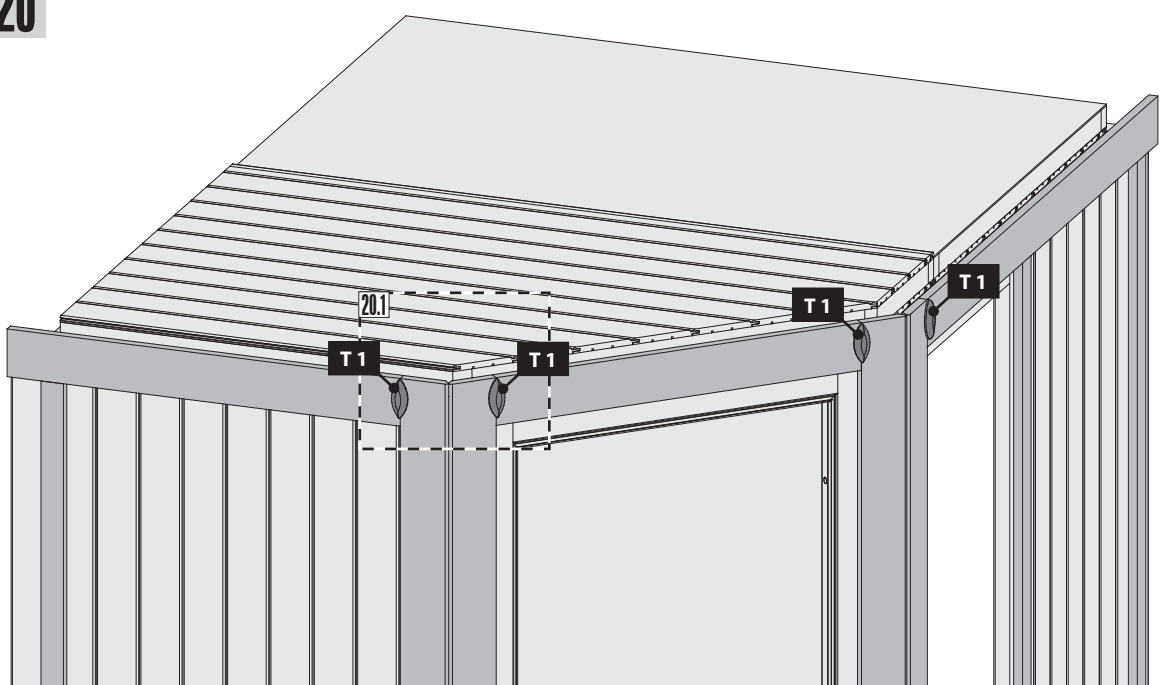

21

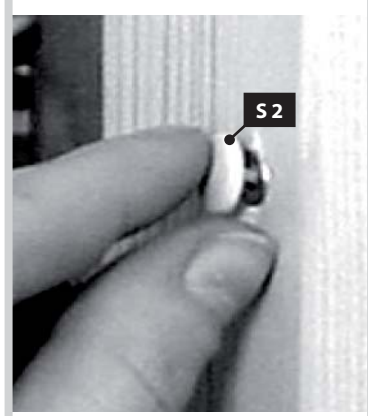

19.1

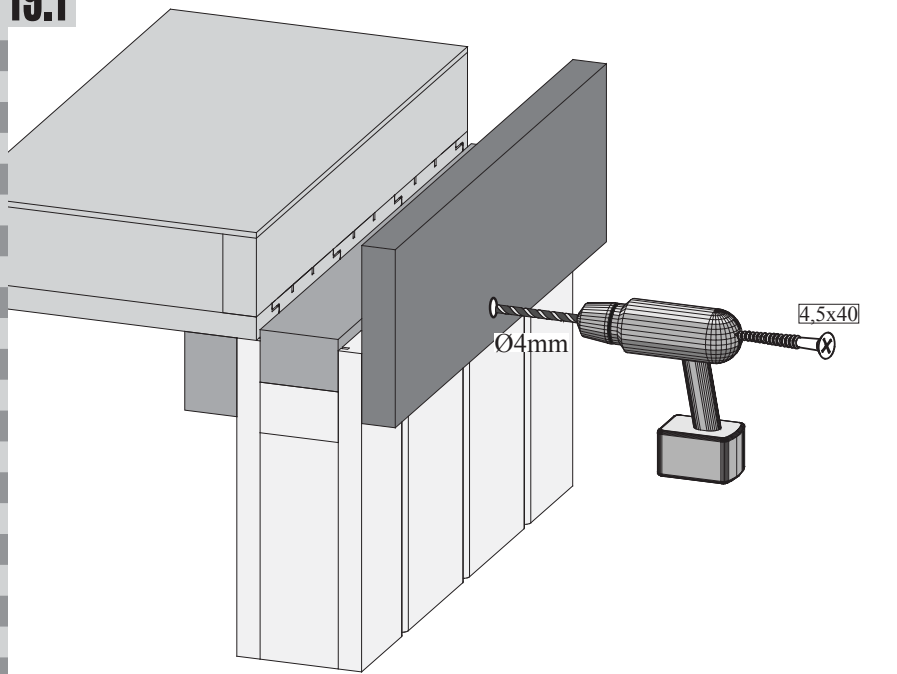

20.1

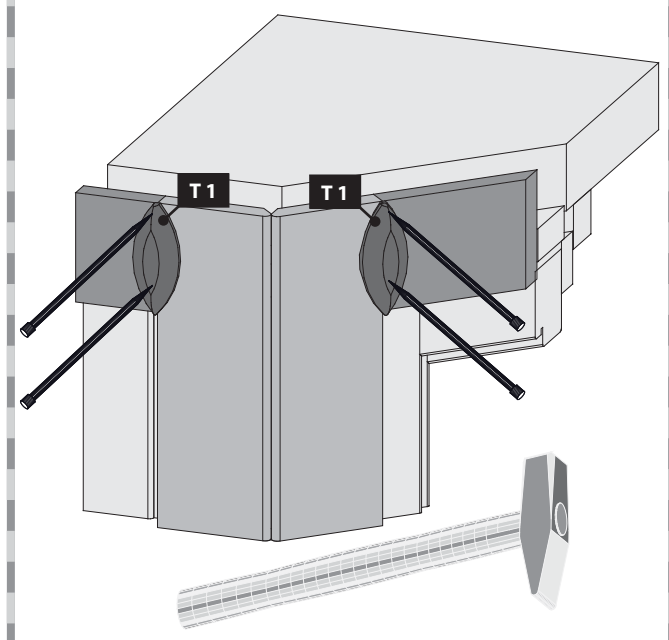

22

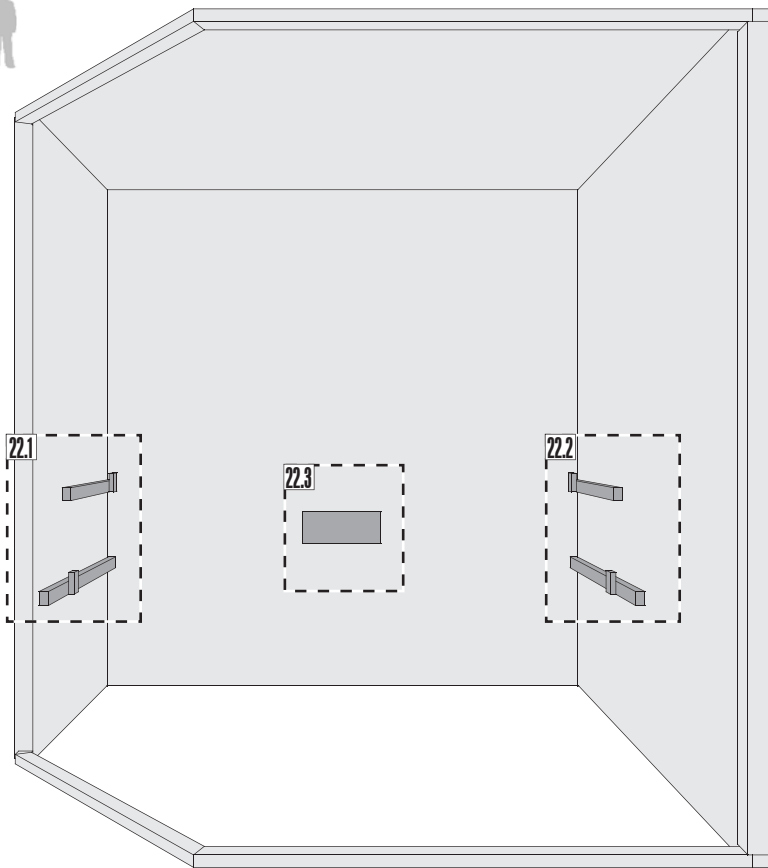
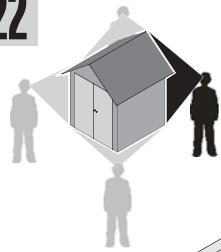

22.1-1

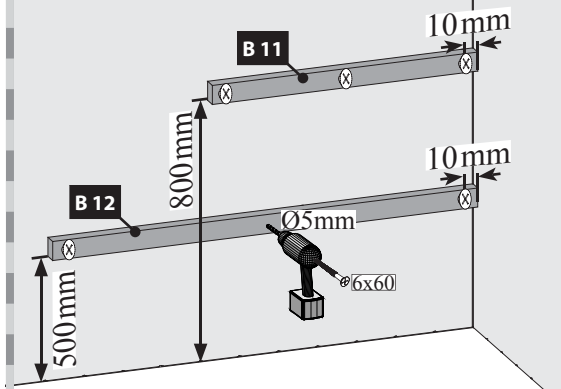

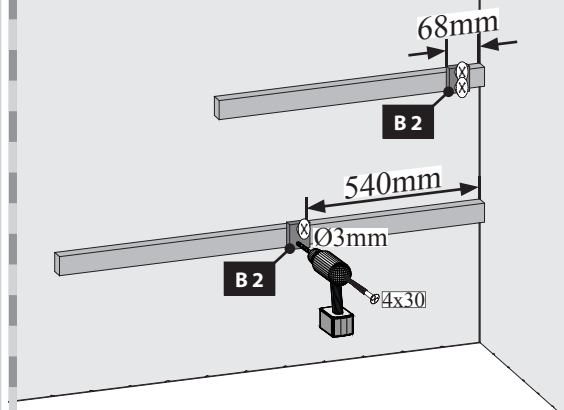

22.1-2



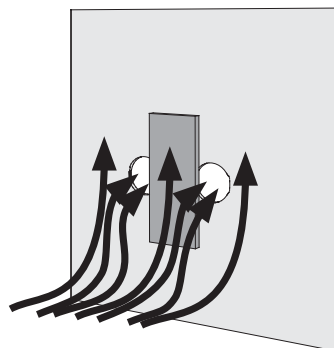
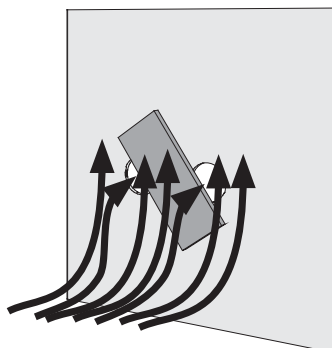
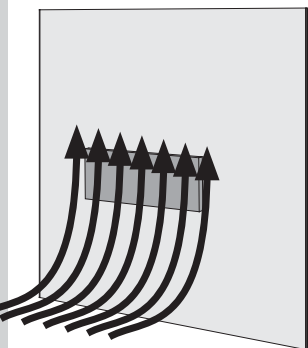
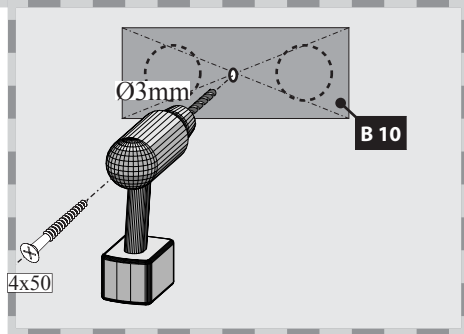

22.3





 Hier ist die Funktionsweise des Brettes abgebildet. Regeln Sie damit die Abluft nach Ihren eigenen Wünschen.

 Hier is de werking van het plankje afgebeeld. Regel daarmee de luchtafvoer naar eigen wens.

 Ceci représente le mode de fonctionnement de la planche. Avec elle, réglez l'écoulement de l'air selon vos désirs.

 Aquí está representada la forma de funcionamiento de la tabla. Regule con ello el aire de salida según sus propios deseos.

 This figure shows the functional principle of the board. Regulate the exhaust air according to your own wishes.

 Viene illustrato il principio di funzionamento della tavoletta di regolazione della ventilazione. Con essa si può regolare a piacere la ventilazione.

22.2-1

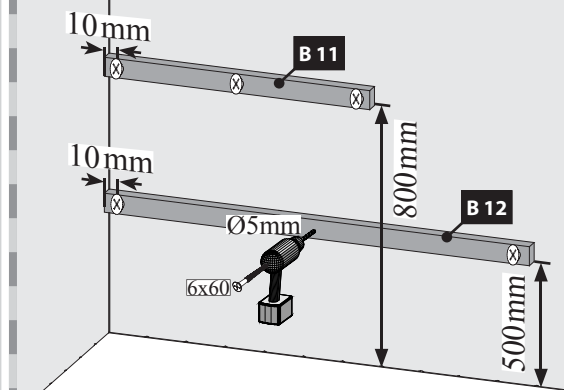

22.2-2

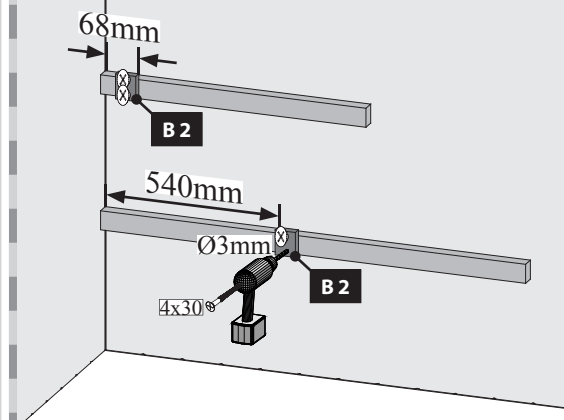

23 2x

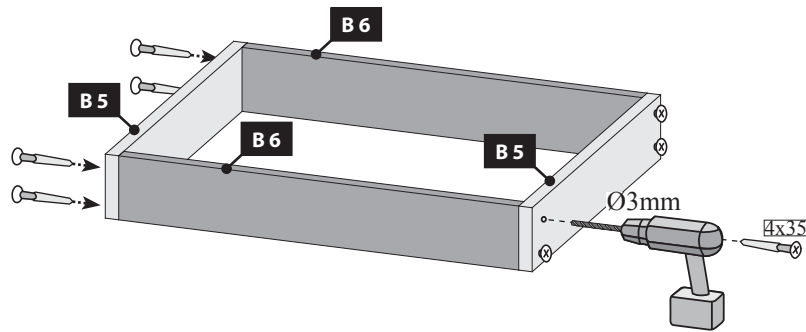

24 a

-  Nur bei 9 kW-Ofen
-  Seulement 9 kW chauffe
-  Only 9 kW heater
-  Slechts 9 kW heater
-  Sólo calentador de 9 kW
-  Solo riscaldamento 9 kW
-  Pouze topné těleso 9 kW

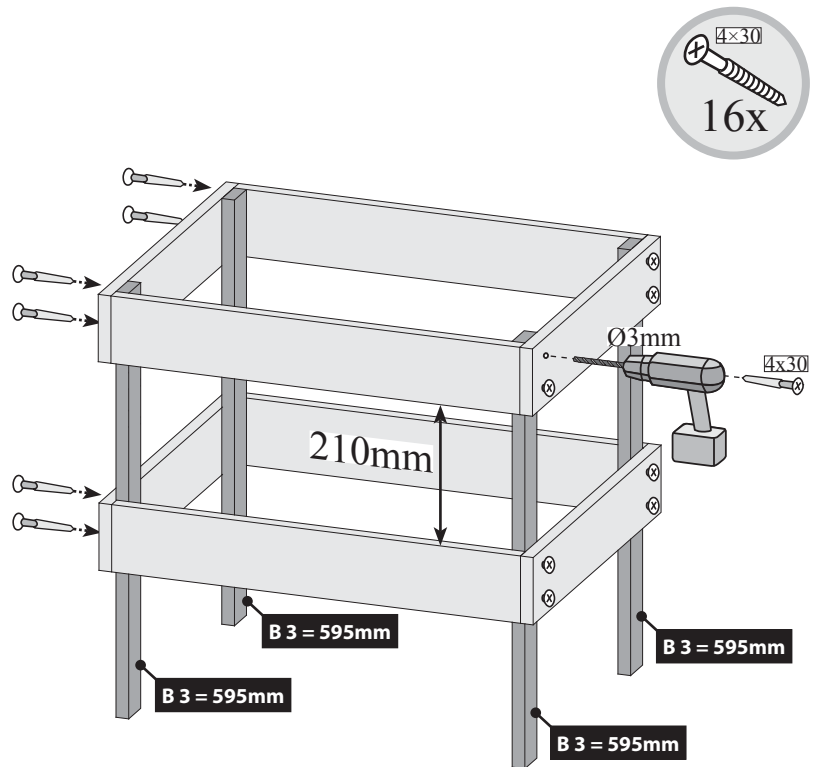
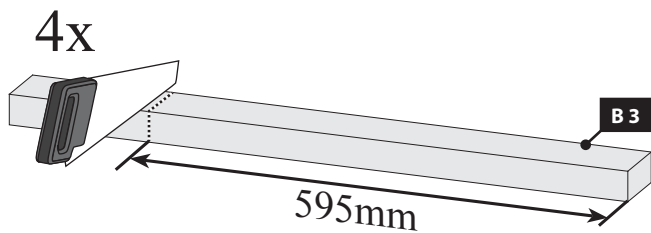

24 b

-  Bei allen anderen Öfen
-  Pour tous les autres fours
-  For all other furnaces
-  Voor alle andere ovens
-  Para todos los otros hornos
-  Per tutti gli altri tipi di forni
-  U všech ostatních pecích

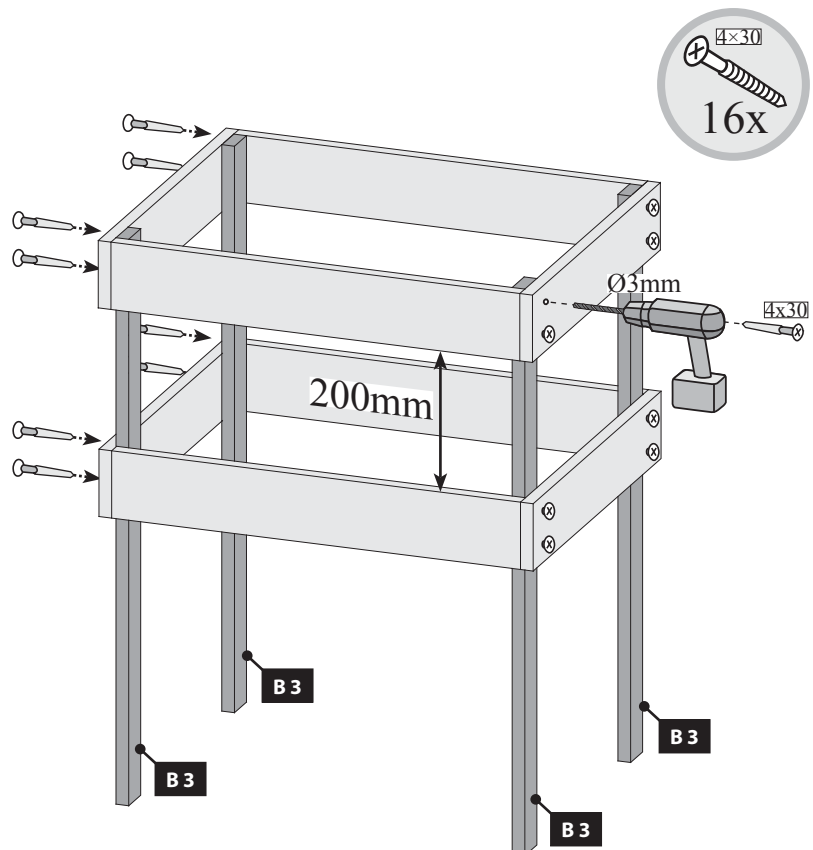

25

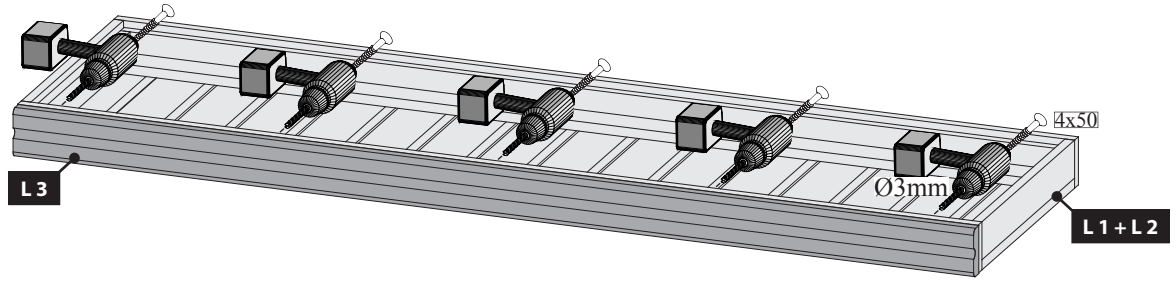
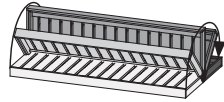

26

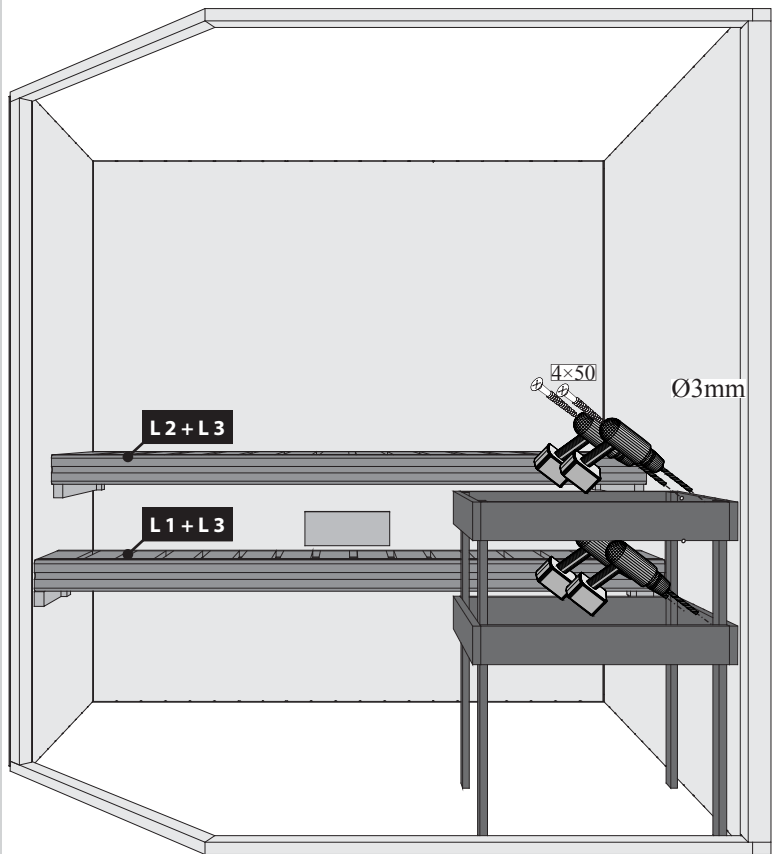

27

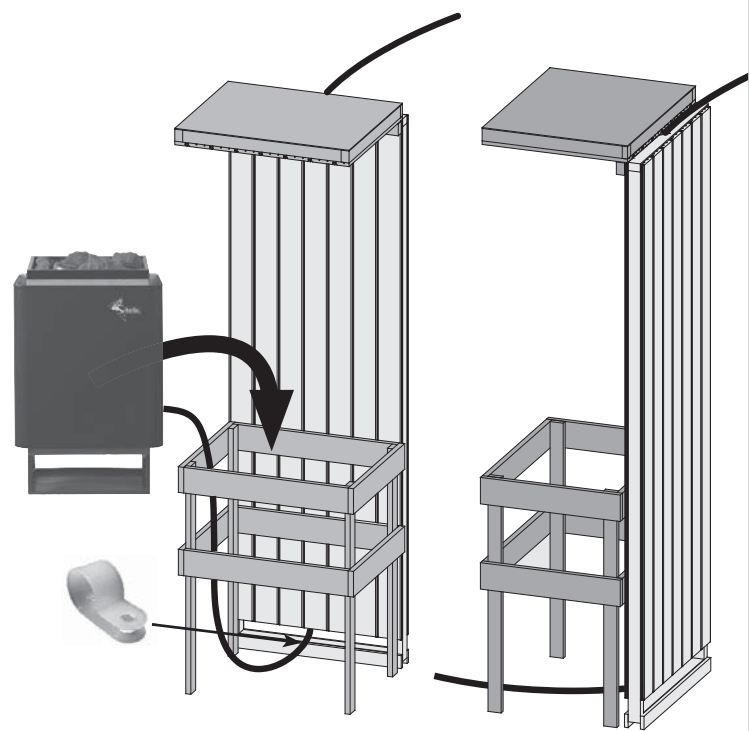

 Einbau Glastür

 Installation of glass door

 Montaje de la puerta de cristal

 Montage porte en verre

 Montage van de glazen deur

 Installazione portello di vetro

!!! 04 — 08 !!!

01

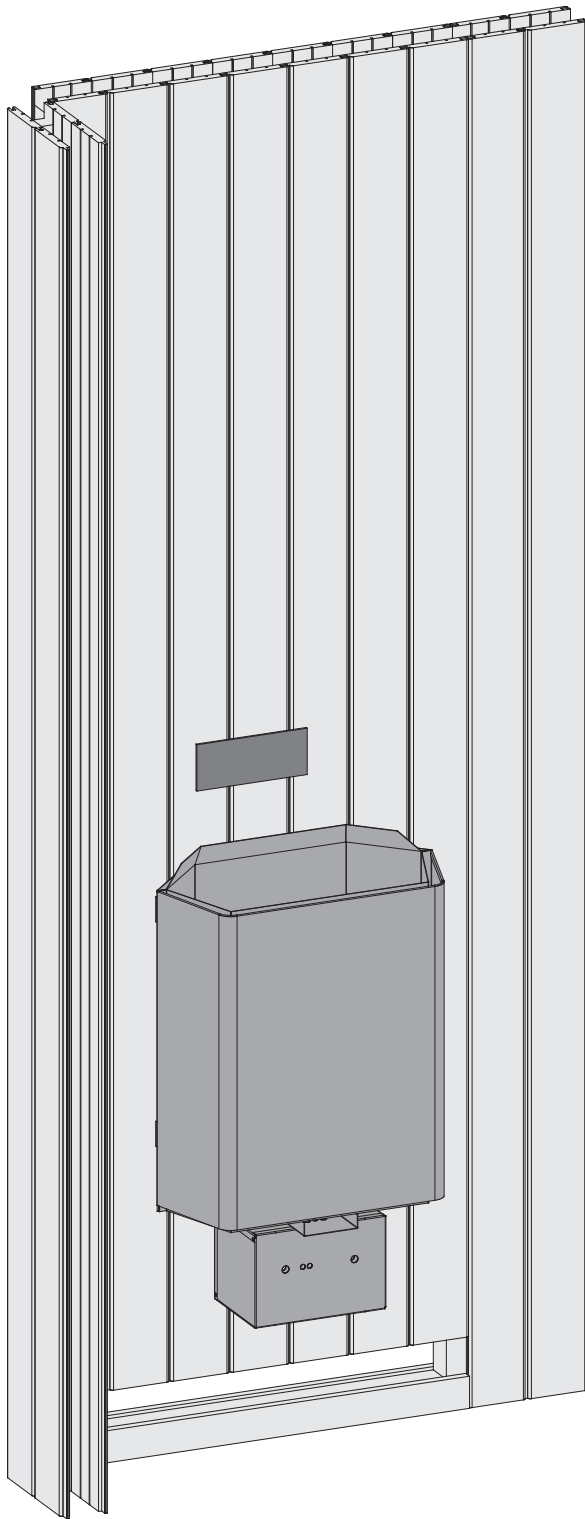

02

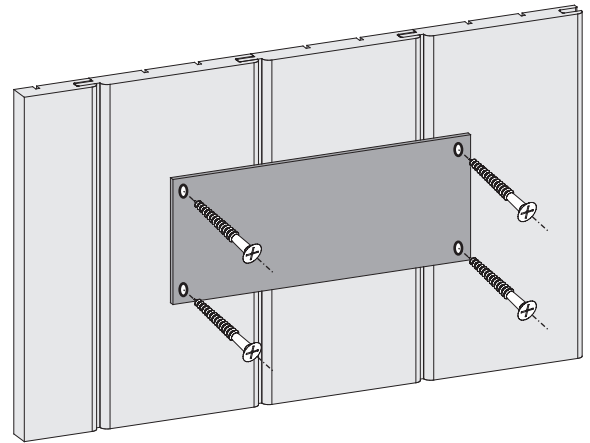

Entfernen Sie die Schutzfolie vom beiliegenden TÜV-Schild.

Lassen Sie den Saunaofen von einem zugelassenen Elektrofachmann anschließen. Dieser markiert den installierten Ofen auf dem TÜV-Schild.

Bringen Sie das TÜV-Schild an einer gut sichtbaren Stelle über dem Ofen an.



 Einbau Saunatür

 Installation de porte Sauna

 Sauna door installation

 Sauna deur installatie

 Instalación de la puerta Sauna

 Installazione porta Sauna

 Sauna Instalace dveře

01

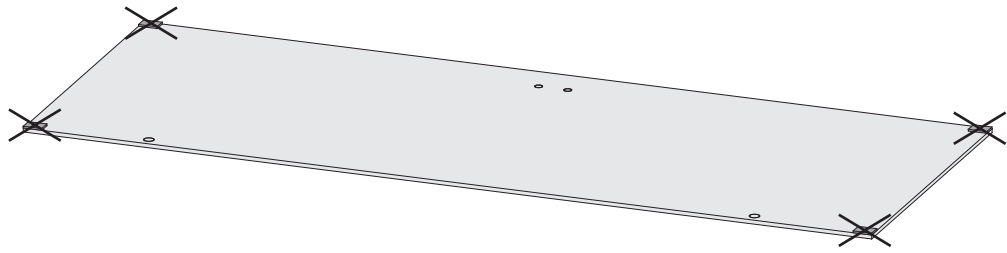

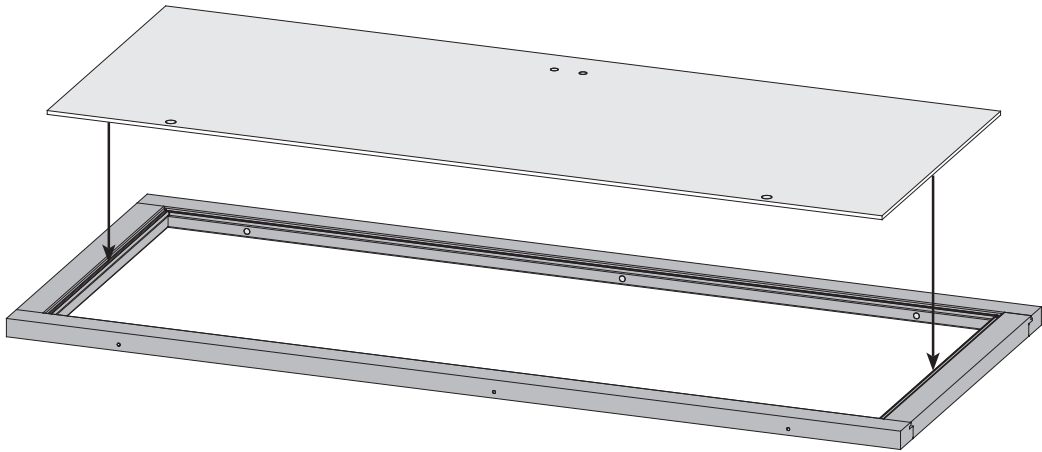

02



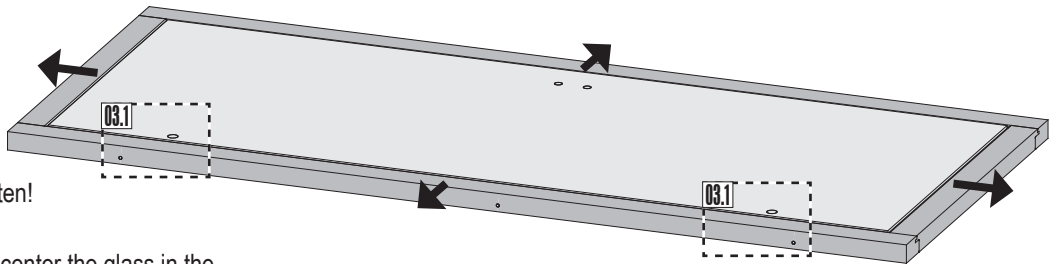

03



 Das Saunatürglas im Türrahmen ausrichten!

 Bien aligner le verre à vitre!

 To start building up the door you need to center the glass in the wooden frame!

 Plaats het glas van de sauna deur in het midden van het kozijn!

 ¡Centrar la puerta de cristal dentro del marco!

 Allineare il vetro dello sportello sauna al telaio della porta!

 Skleněná dvířka sauna v zárubně zarovnáni!

03.1-1

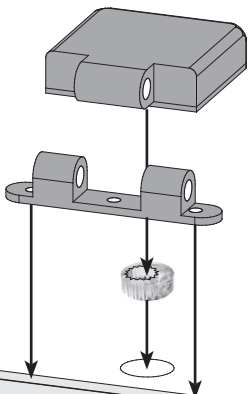

03.1-2

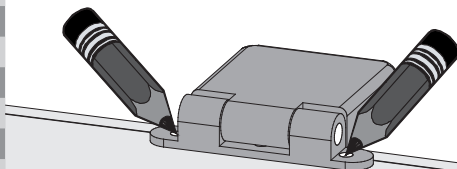

03.1-3

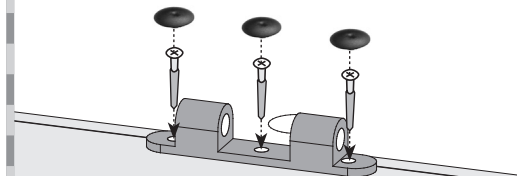

 Einbau Saunatür

 Sauna deur installatie

 Sauna Instalace dveře

 Installation de porte Sauna

 Instalación de la puerta Sauna

 Sauna door installation

 Installazione porta Sauna

04

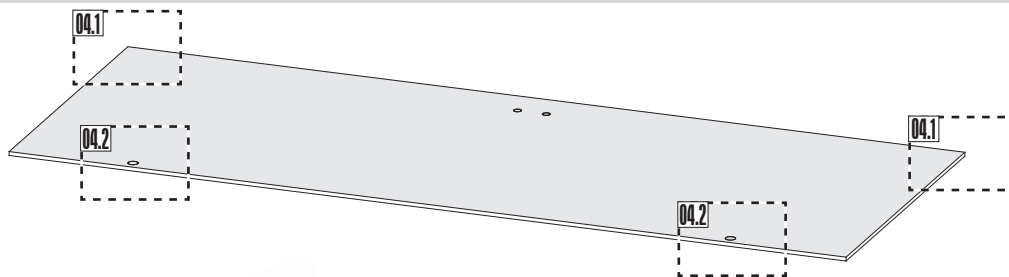

04.1-1

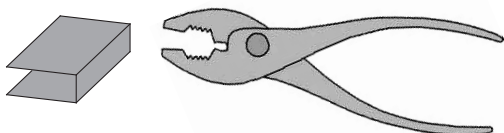

04.1-2

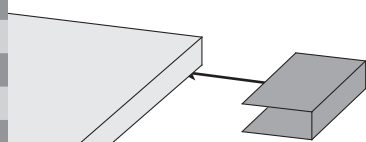

04.1-3

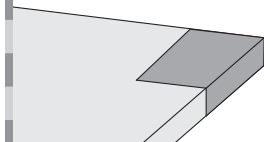

04.2-1

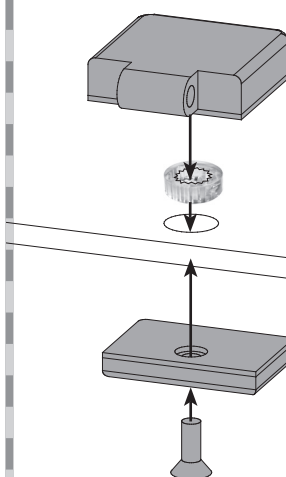

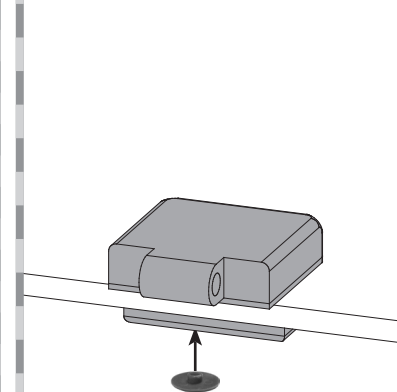

04.2-2



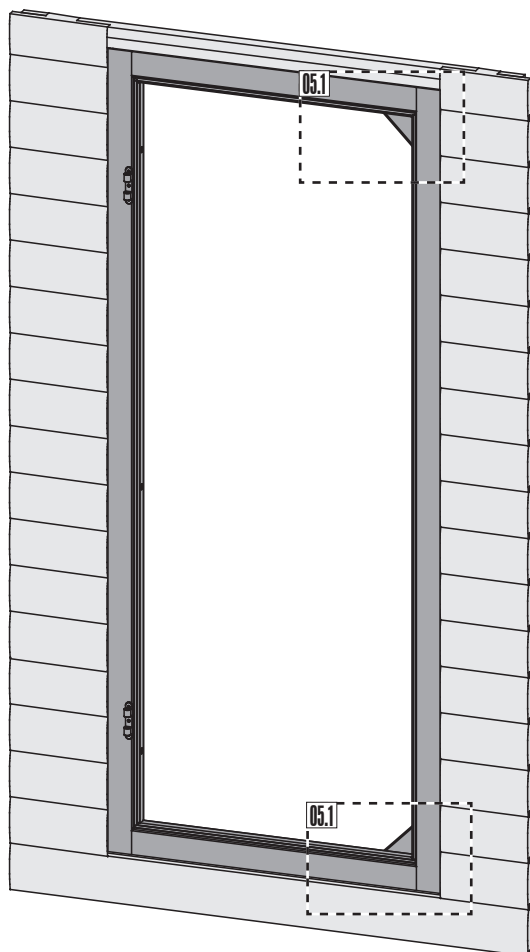

05





 Achtung: Alle Verstell-Excenter müssen in der Glasscheibe die gleiche Grundstellung haben!

 Attention: Tous les excenteurs de positionnement doivent avoir la même position de base dans la vitre!

 Attention: All adjustable eccentrics must have the same basic adjustment in the glass panel!

 Attentie: alle excentrische verstelelementen moeten in dezelfde stand in de glasplaat worden geplaatst!

 Atención: Todos los excéntricos regulables tienen que tener la misma posición base en la hoja de cristal.

 Attenzione: Tutti gli eccentrici di regolazione devono avere la stessa posizione base nella lastra di vetro!

 Poznámka: Všechny nastavovací podivínů musí mít stejný základní polohy ve skle!

05.1-1



05.1-2



 Einbau Saunatür

 Sauna deur installatie

 Sauna Instalace dveře

 Installation de porte Sauna

 Instalación de la puerta Sauna

 Sauna door installation

 Installazione porta Sauna

06

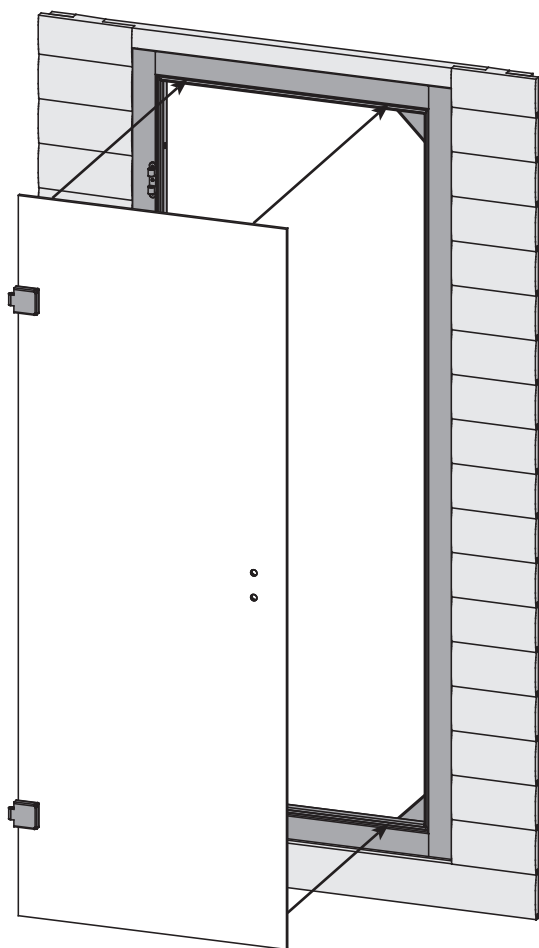

07

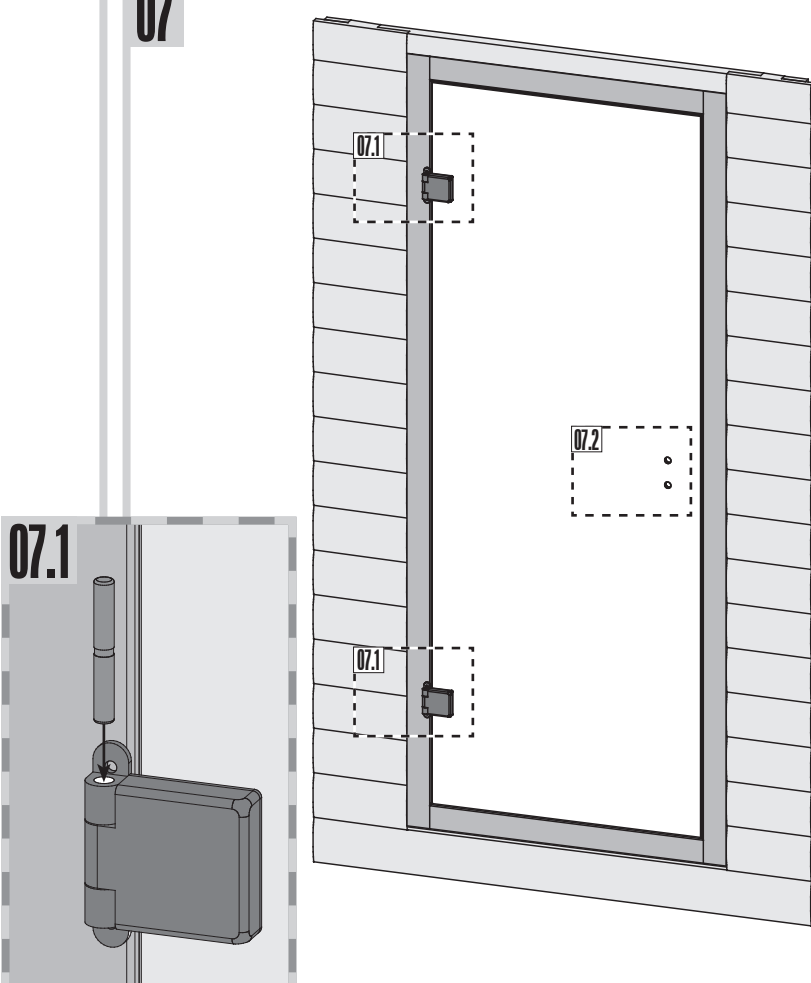

07.2-1

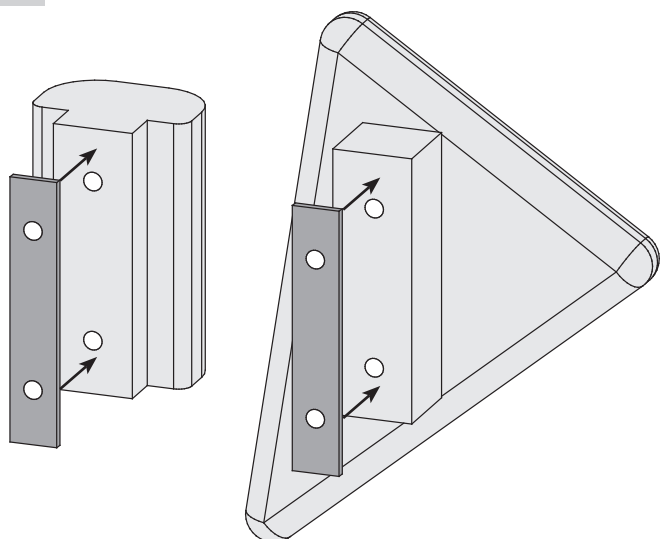

07.2-2

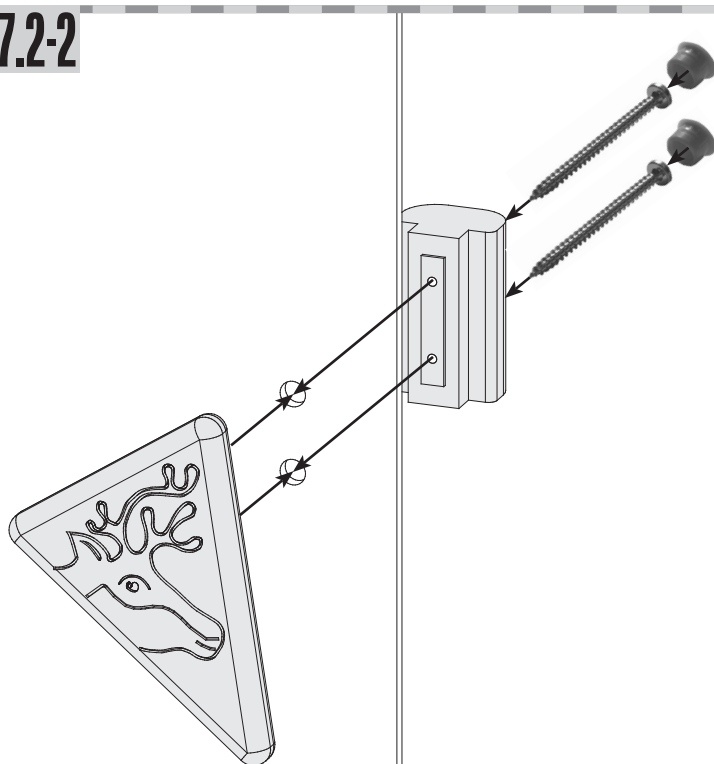

 Einbau Saunatür

 Sauna deur installatie

 Sauna Instalace dveře

 Installation de porte Sauna

 Instalación de la puerta Sauna

 Sauna door installation

 Installazione porta Sauna

08

 **Seitenverstellung + Höhenverstellung**

Achtung: Alle Verstell-Excenter müssen in der Glasscheibe die gleiche Grundstellung haben!

 **Positionnement latéral + positionnement hauteur**

Attention: Tous les excentres de positionnement doivent avoir la même position de base dans la vitre!

 **Lateral adjustment + height adjustment**

Attention: All adjustable eccentrics must have the same basic adjustment in the glass panel!

 **Zijverstelling + hoogteverstelling**

Attentie: alle excentrische verstelelementen moeten in dezelfde stand in de glasplaat worden geplaatst!

 **Regulación lateral + regulación de la altura**

Atención: Todos los excéntricos regulables tienen que tener la misma posición base en la hoja de cristal.

 **Regolazione laterale + regolazione dell'altezza**

Attenzione: Tutti gli eccentrici di regolazione devono avere la stessa posizione base nella lastra di vetro!

 **Boční nastavení + nastavení výšky**

Poznámka: Všechny nastavovací podivínů musí mít stejný základní polohy ve skle!

